

EUROPEAN

E2

Material: cast iron and aluminium

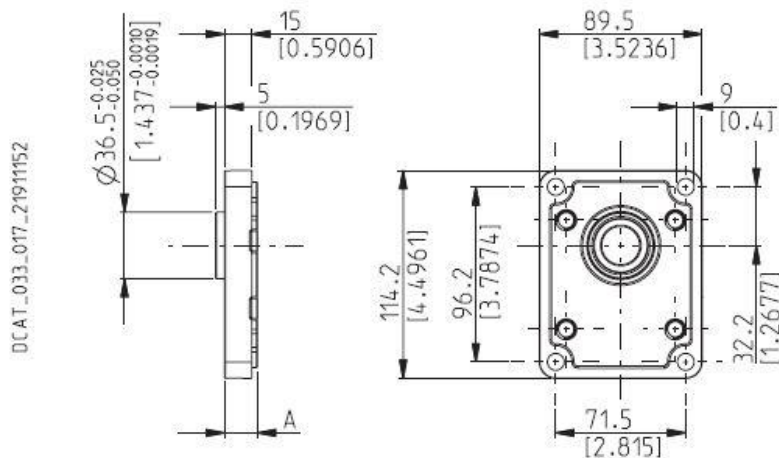

VERSION

9

Available for group:

20

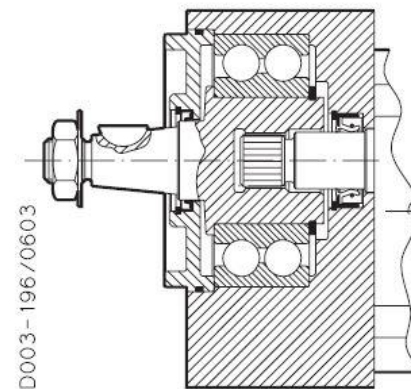

Series	Pump type PLP Motor type PLM	Displacement in ³ /rev (cm ³ /rev)	Max. pressure			Max. speed	Min. speed
			p ₁	p ₂	p ₃		
			psi (bar)			min ⁻¹	
POLARIS 20	PL. 20•4	0.30 (4,95)	3625 (250)	4060 (280)	4350 (300)	4000	600
	PL. 20•6,3	0.40 (6,61)	3625 (250)	4060 (280)	4350 (300)	4000	600
	PL. 20•7,2	0.44 (7,29)	3625 (250)	4060 (280)	4350 (300)	4000	600
	PL. 20•8	0.50 (8,26)	3625 (250)	4060 (280)	4350 (300)	3500	600
	PL. 20•9	0.56 (9,17)	3625 (250)	4060 (280)	4350 (300)	3500	600
	PL. 20•10,5	0.66 (10,9)	3625 (250)	4060 (280)	4350 (300)	3500	600
	PL. 20•11,2	0.69 (11,23)	3625 (250)	4060 (280)	4350 (300)	3500	600
	PL. 20•14	0.89 (14,53)	3625 (250)	4060 (280)	4350 (300)	3500	500
	PL. 20•16	1.03 (16,85)	3625 (250)	4060 (280)	4350 (300)	3000	500
	PL. 20•19	1.16 (19,09)	2900 (200)	3190 (220)	3480 (240)	3000	500
	PL. 20•20	1.29 (21,14)	2900 (200)	3190 (220)	3480 (240)	3000	500
	PL. 20•24,5	1.52 (24,84)	2465 (170)	2755 (190)	3045 (210)	2500	500
	PL. 20•25	1.61 (26,42)	2465 (170)	2755 (190)	3045 (210)	2500	500
	PL. 20•27,8	1.72 (28,21)	1885 (130)	2175 (150)	2465 (170)	2000	500
PL. 20•31,5	2.01 (33,03)	1885 (130)	2175 (150)	2465 (170)	2000	500	

EUROPEAN TAPERED 1:8

82

Not available with size:

20•10,5 - 20•24,5 - 20•27,8

Mounting face refer to flange code E2

