

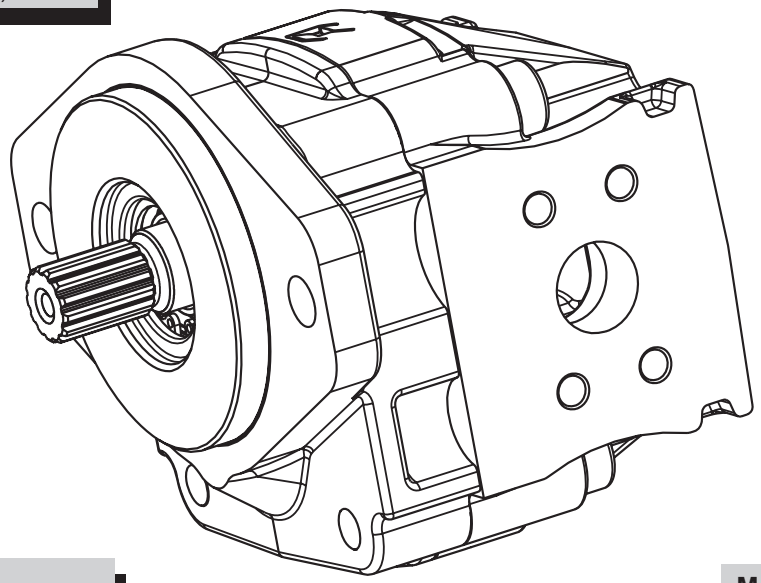

Hydraulic gear pumps and motors compact design

DISPLACEMENTS

From	1.34 in ³ /rev (21,99 cm ³ /rev)
To	9.20 in ³ /rev (150,79 cm ³ /rev)



PRESSURE

Max. Continuous	4350 psi (300 bar)
Max. Intermittent	4568 psi (315 bar)
Max. Peak	4713 psi (325 bar)

MAX. SPEED

3000 min ⁻¹

- High operating pressures
- Low noise emission
- Available with built-in valves
- Exceptional working life expectancy

From the KAPPA series, we now introduce the KAPPA "Compact" line. The main feature of this new line is a solid, compact 2-piece construction. The new Kappa "Compact" line allows you to include many functions in a reduced envelope (space). The new KAPPA "Compact" line is a direct result of feedback received from Casappa customers. This feedback has given Casappa the opportunity to understand the needs of our customers and implement the hydraulic knowledge gained into new and improved products. The "Compact" line provides exceptional quality and reliability thanks to tri-dimensional modeling, virtual simulation of the pump's behavior in the hydraulic system and testing on the machines. The reduced dimensions as well as a large variety of drive shafts, mounting flanges and ports ensure great flexibility in the "Compact" line.



INDEX

Section	Page
FEATURES	1
GENERAL DATA	3
PUMP PERFORMANCE CURVES	5
MOTOR PERFORMANCE CURVES	12
SINGLE UNITS DIMENSIONS	19
MULTIPLE PUMPS	24
MULTIPLE PUMPS DIMENSION	26
VERSIONS (OUTBOARD BEARINGS FOR SHAFTS)	35
DRIVE SHAFTS	38
MOUNTING FLANGES	41
PORTS	47
MOTORS KM30 WITH BUILT-IN VALVES	51
CHANGING ROTATION	53
INSTRUCTIONS	54
HOW TO ORDER	55

Replaces: 02/11.04

03/07.05

○ **Modification from former edition.**

FEATURES

Replaces: 01/05.02

Construction	External gear type pumps and motors
Mounting	EUROPEAN - SAE - standard flanges
Line connections	Screw and flange
Direction of rotation (looking at the drive shaft)	Anti-clock (S) - clockwise (D) - reversible external drain (R) reversible internal drain (B)
Inlet pressure range for pumps	10 ÷ 44 psi - [0,7 ÷ 3 bar (abs.)]
Max back pressure for single rotation motors	p_1 (continuous) max 73 psi (5 bar)
	p_2 (for 20 s) max 116 psi (8 bar)
	p_3 (for 8 s) max 218 psi (15 bar)
Max drain line pressure on reversible rotation motors	73 psi (5 bar)
Max back pressure on the series motors	2175 psi (150 bar)
Fluid temperature range	See table (1)
Fluid	Mineral oil based hydraulic fluids to ISO/DIN and fire resistant fluids [see table (1)]. For other fluids please consult our technical sales department.
Viscosity range	From 60 to 456 SSU [12 to 100 mm ² /s (cSt)] recommended
	Up to 3410 SSU [750 mm ² /s (cSt)] permitted
Filtering requirement	See table (2)

Tab. 1

Type	Fluid composition	Max pressure psi - (bar)	Max speed min ⁻¹	Temperature °F - (°C) ●			Seals (◆)
				Min	Max continuous	Max peak	
ISO/DIN	Mineral oil based hydraulic fluid to ISO/DIN	See page 3	See page 3	-13 (-25)	176 (80)	212 (100)	N
				-13 (-25)	230 (110)	257 (125)	N-H
HFA	Oil emulsion in water 5 ÷ 15% of oil	725 (50)	1500	36 (2)	131 (55)		N
HFB	Water emulsion in oil 40 % of water	1740 (120)	1500	36 (2)	140 (60)		N
HFC	Water - glycol	1450 (100)	1500	-4 (-20)	140 (60)		N Bz
HFD	Phosphate ester	2175 (150)	1500	14 (-10)	176 (80)		V Bz

(◆) **N**= Buna N (standard) - **N-H**= Buna N and high back pressure shaft seals - **V**= Viton
N Bz= Buna N and Bronze thrust plates - **V Bz**= Viton and Bronze thrust plates

Tab. 2

Working pressure	$\Delta p > 2900$ psi - (200 bar)	$\Delta p < 2900$ psi - (200 bar)
Contamination class NAS 1638	8	10
Contamination class ISO 4406	19/17/14	21/19/16
Achieved with filter $\beta_{x \geq 75}$	10 μ m	25 μ m

Casappa recommends to use its own production filters:



● 03/07.05

General Notes

Available with different inlet and outlet ports. If you use fire resistant fluids, specify the fluid type when ordering.
 For more information please consult our technical sales department.

FEATURES

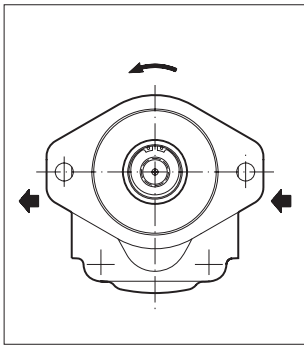
DEFINITION OF ROTATION DIRECTION LOOKING AT THE DRIVE SHAFT



Anti-clock rotation

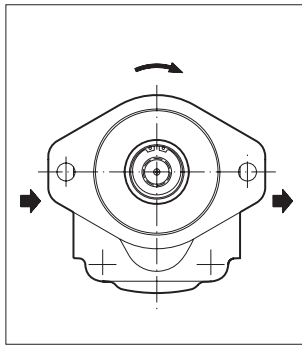

Clockwise rotation

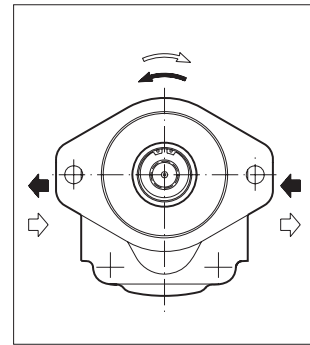

Reversible rotation

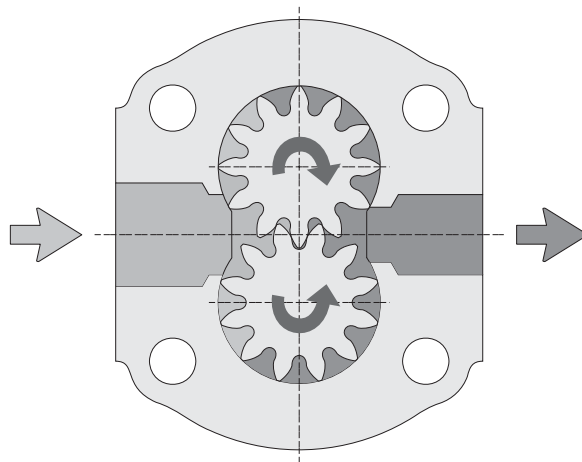

PRESSURE DEFINITION

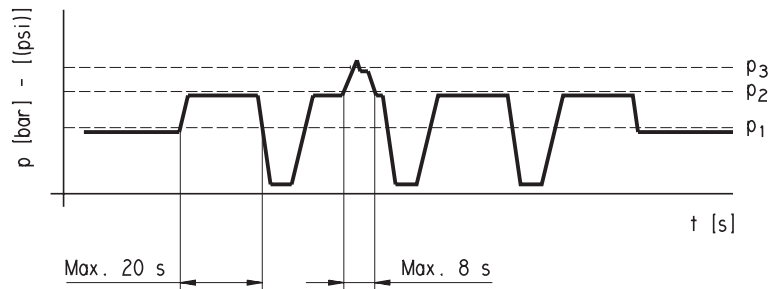

- p_1 Max. continuous pressure
- p_2 Max. intermittent pressure
- p_3 Max. peak pressure

01/05.02

GENERAL DATA

Pump type Motor type	Displacement	Max. pressure			Max. speed	Min. speed
		p ₁	p ₂	p ₃		
	in ³ /rev (cm ³ /rev)	psi (bar)			min ⁻¹	
K. 30•22	1.34 (21,99)	4060 (280)	4350 (300)	4495 (310)	3000	350
K. 30•27	1.63 (26,7)	4060 (280)	4350 (300)	4495 (310)	3000	350
K. 30•31	1.87 (30,63)	3770 (260)	4060 (280)	4350 (300)	3000	350
K. 30•34	2.11 (34,56)	3770 (260)	4060 (280)	4350 (300)	3000	350
K. 30•38	2.40 (39,27)	3770 (260)	4060 (280)	4350 (300)	3000	350
K. 30•41	2.54 (41,62)	3625 (250)	3915 (270)	4205 (290)	3000	350
K. 30•43	2.68 (43,98)	3625 (250)	3915 (270)	4205 (290)	3000	350
K. 30•46	2.83 (46,34)	3625 (250)	3915 (270)	4205 (290)	3000	350
K. 30•51	3.16 (51,83)	3335 (230)	3625 (250)	3915 (270)	2500	350
K. 30•56	3.45 (56,54)	3118 (215)	3408 (235)	3698 (255)	2500	350
K. 30•61	3.74 (61,26)	2900 (200)	3190 (220)	3480 (240)	2500	350
K. 30•73	4.50 (73,82)	2610 (180)	2900 (200)	3190 (220)	2500	350
K. 40•63	3.75 (61,43)	4350 (300)	4568 (315)	4713 (325)	2800	300
K. 40•73	4.43 (72,6)	4350 (300)	4568 (315)	4713 (325)	2800	300
K. 40•87	5.28 (86,56)	4060 (280)	4278 (295)	4423 (305)	2800	300
K. 40•109	6.64 (108,9)	3625 (250)	3843 (265)	3988 (275)	2800	300
K. 40•121	7.43 (121,8)	3335 (230)	3553 (245)	3698 (255)	2500	300
K. 40•133	8.18 (134,03)	3190 (220)	3408 (235)	3553 (245)	2500	300
K. 40•151	9.20 (150,79)	2900 (200)	3118 (215)	3263 (225)	2500	300

 p₁= Max. continuous pressure

 p₂= Max. intermittent pressure

 p₃= Max. peak pressure

The values in the table refer to unidirectional pumps and motors
 Reversible pumps and motors max pressures are 15% lower than those shown in table.
 For different working conditions please consult our sales department.

Replaces: 01/05.02

03/07.05

GENERAL DATA PUMPS AND MOTORS

Q	US gpm (l/min)	Flow
M	lbf in (Nm)	Torque
P	HP (kW)	Power
V	in ³ /rev (cm ³ /rev)	Displacement
n	min ⁻¹	Speed
Δp	psi (bar)	Pressure

Efficiencies ○

		Pumps	Motor
$\eta_v = \eta_v(V, \Delta p, n)$	Volumetric efficiency	($\approx 0,98$)	($\approx 0,97$)
$\eta_m = \eta_m(V, \Delta p, n)$	Mechanical efficiency	($\approx 0,90$)	($\approx 0,88$)
$\eta_t = \eta_v \cdot \eta_m$	Overall efficiency	($\approx 0,88$)	($\approx 0,85$)

DESIGN CALCULATIONS FOR PUMP

$$Q = V(\text{cm}^3/\text{rev}) \cdot \eta_v \cdot n \cdot 10^{-3} \quad [\text{l/min}]$$

$$M = \frac{\Delta p (\text{bar}) \cdot V (\text{cm}^3/\text{rev})}{62,83 \cdot \eta_m} \quad [\text{Nm}]$$

$$P = \frac{\Delta p (\text{bar}) \cdot V (\text{cm}^3/\text{rev}) \cdot n}{600 \cdot 1000 \cdot \eta_t} \quad [\text{kW}]$$

DESIGN CALCULATIONS FOR MOTOR

$$Q = \frac{V (\text{cm}^3/\text{rev}) \cdot n \cdot 10^{-3}}{\eta_v} \quad [\text{l/min}]$$

$$M = \frac{\Delta p (\text{bar}) \cdot V (\text{cm}^3/\text{rev}) \cdot \eta_m}{62,83} \quad [\text{Nm}]$$

$$P = \frac{\Delta p (\text{bar}) \cdot V (\text{cm}^3/\text{rev}) \cdot n \cdot \eta_t}{600 \cdot 1000} \quad [\text{kW}]$$

Note: Diagrams providing approximate selection data will be found on subsequent pages.

Replaces: 01/05.02

○ 03/07.05

KAPPA 30 GEAR PUMPS PERFORMANCE CURVES

KP 30

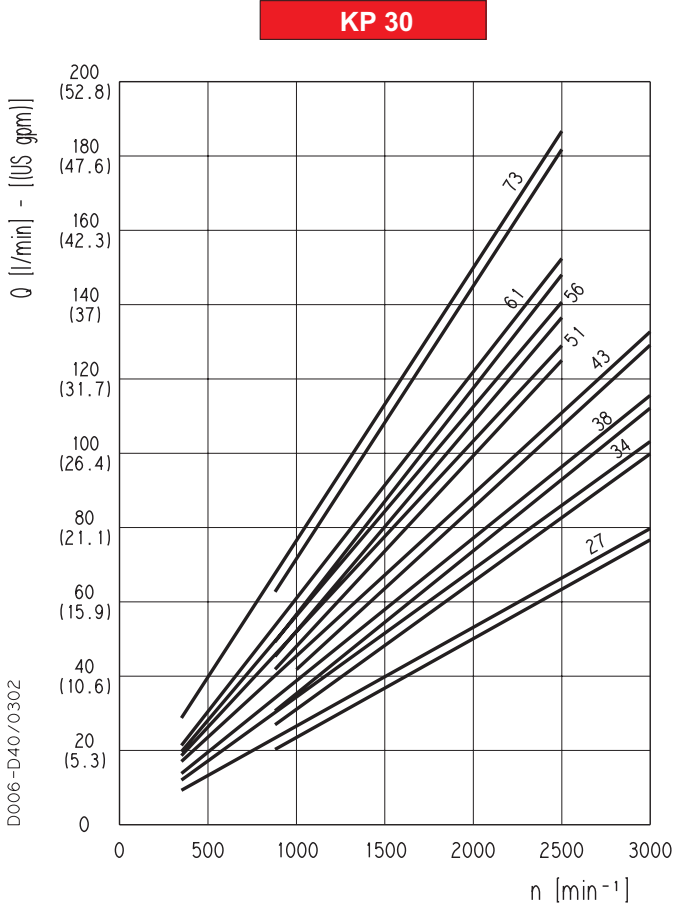

Each curve has been obtained at 122 °F (50°C), using oil with viscosity 168 SSU (36 cSt) at 104 °F (40°C) and at these pressures.

- KP 30•27 290-4060 psi (20-280 bar)
- KP 30•34 290-3770 psi (20-260 bar)
- KP 30•38 290-3770 psi (20-260 bar)
- KP 30•43 290-3625 psi (20-250 bar)
- KP 30•51 290-3335 psi (20-230 bar)
- KP 30•56 290-3118 psi (20-215 bar)
- KP 30•61 290-2900 psi (20-200 bar)
- KP 30•73 290-2610 psi (20-180 bar)

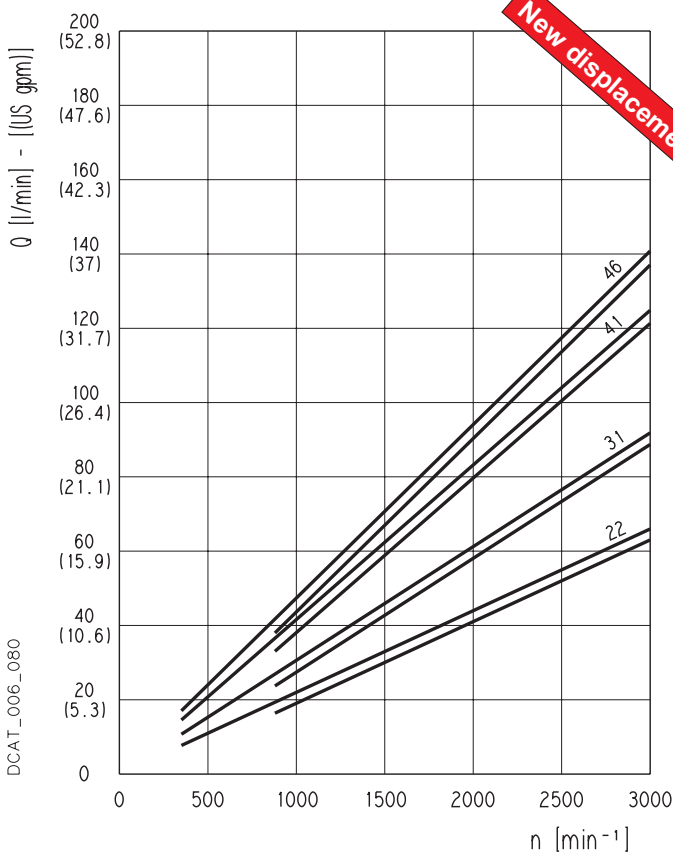

- KP 30•22 290-4060 psi (20-280 bar)
- KP 30•31 290-3770 psi (20-260 bar)
- KP 30•41 290-3625 psi (20-250 bar)
- KP 30•46 290-3625 psi (20-250 bar)

01/05.02

KAPPA 30 GEAR PUMPS PERFORMANCE CURVES

KP 30

KP 30•22

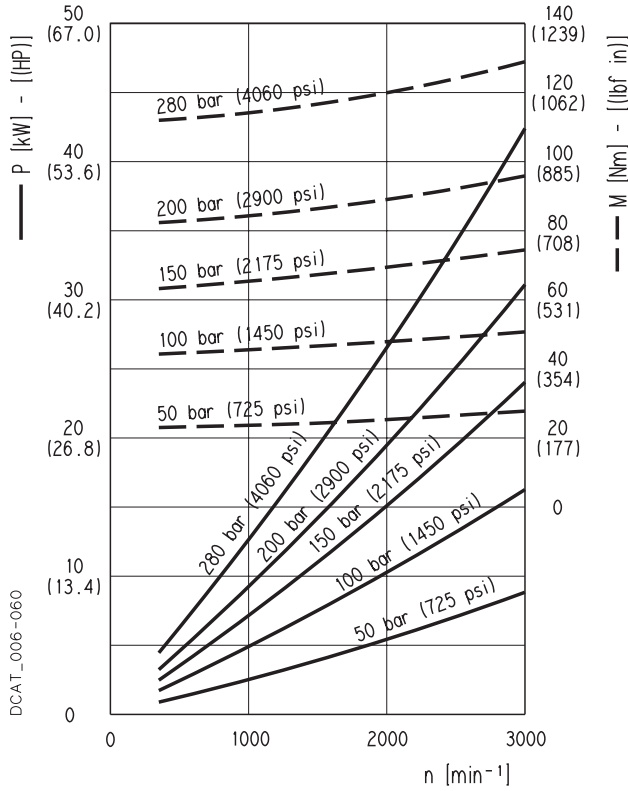

KP 30•27

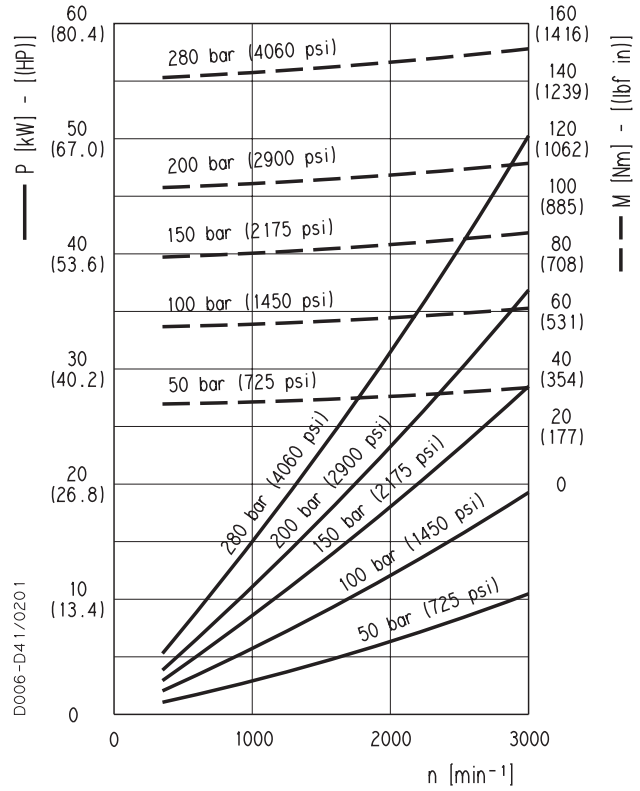

KP 30•31

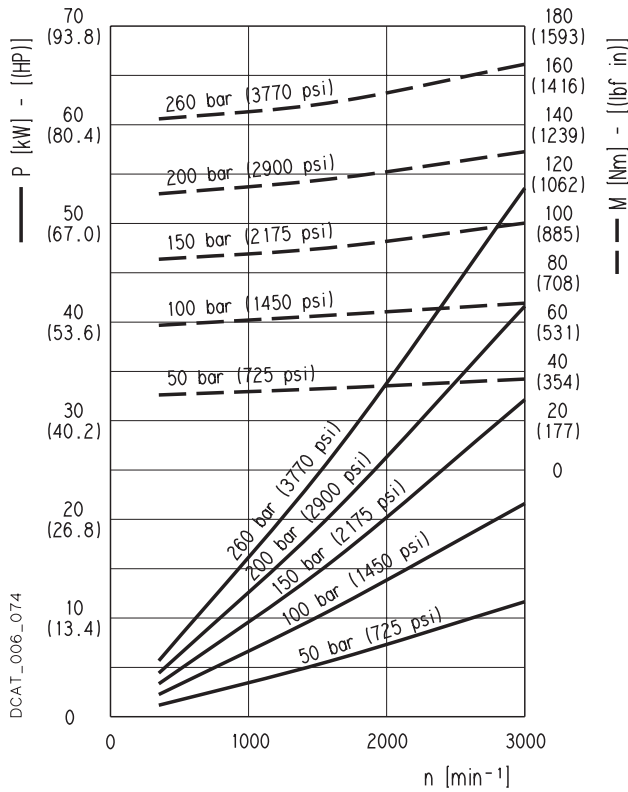

KP 30•34

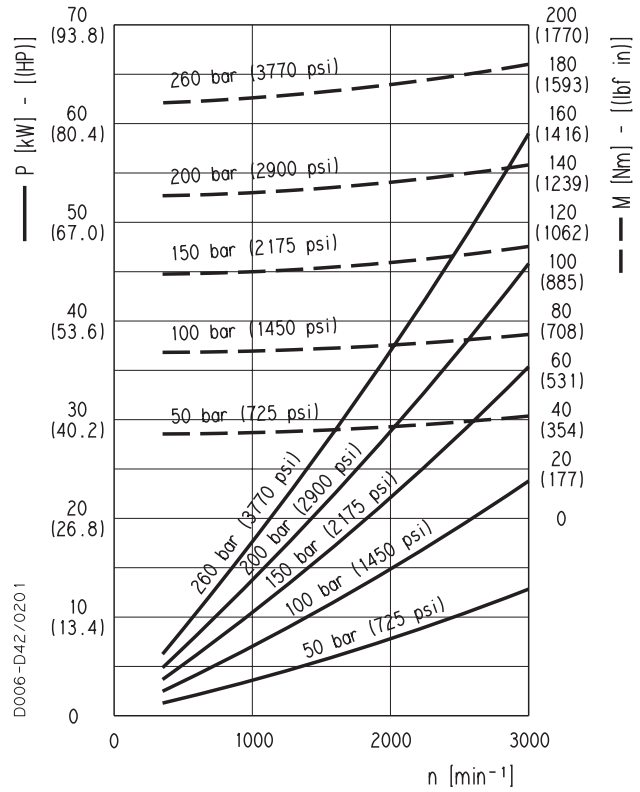

01/05.02

KAPPA 30 GEAR PUMPS PERFORMANCE CURVES

KP 30

KP 30-38

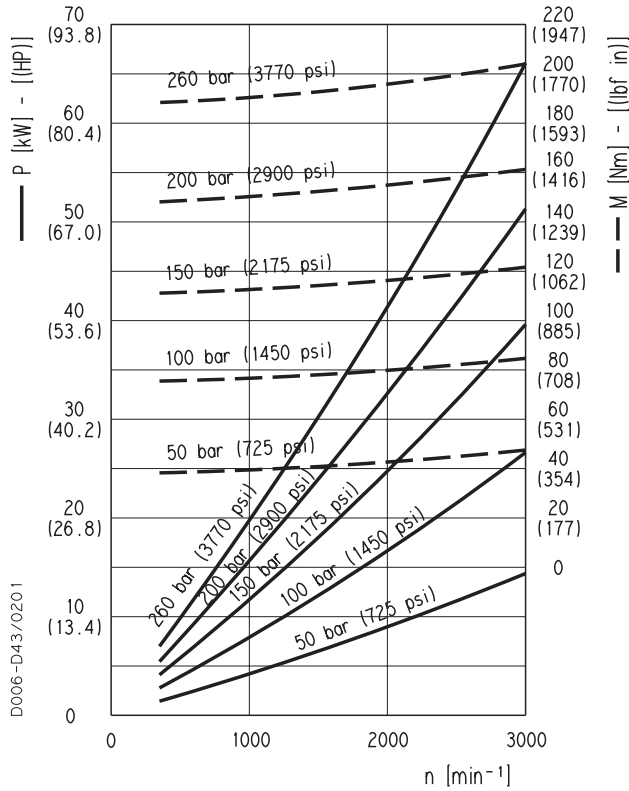

KP 30-41

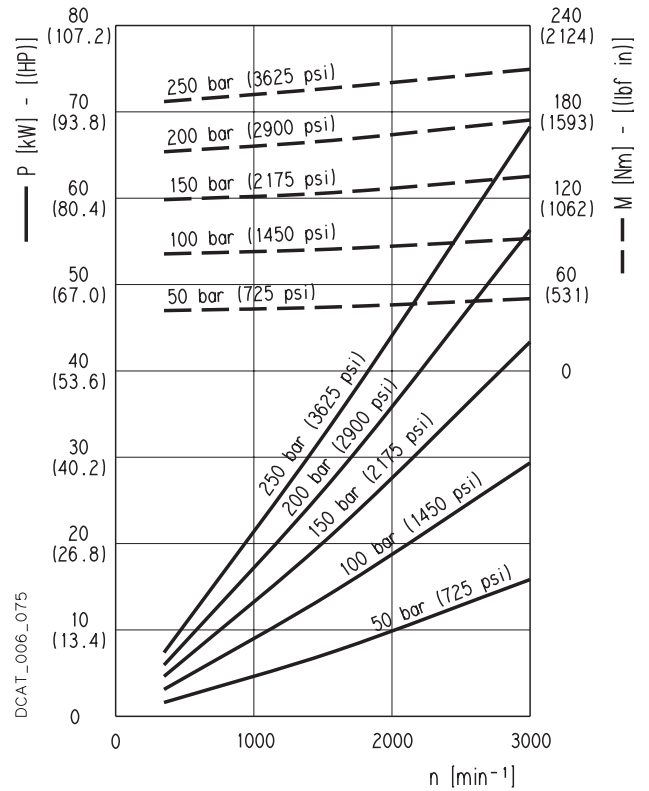

KP 30-43

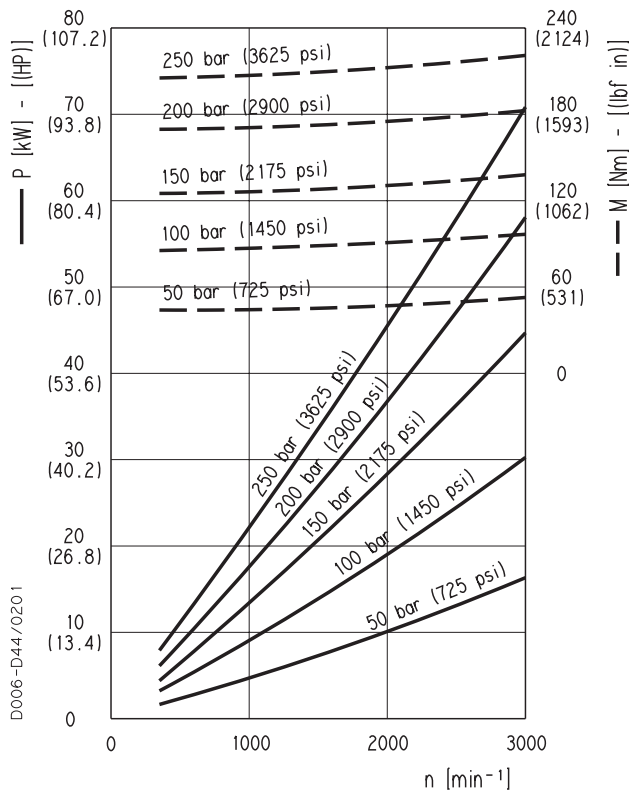

KP 30-46

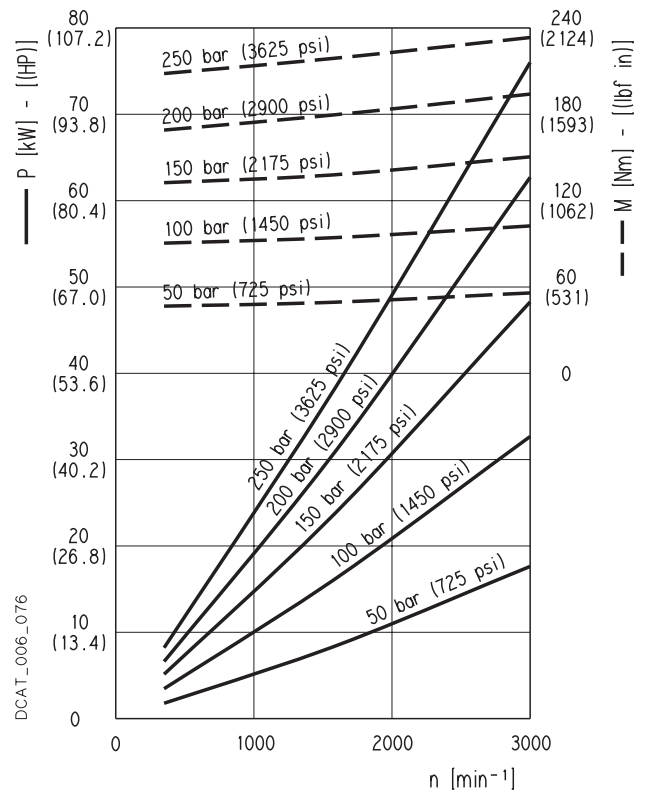

01/05.02

KAPPA 30 GEAR PUMPS PERFORMANCE CURVES

KP 30

KP 30•51

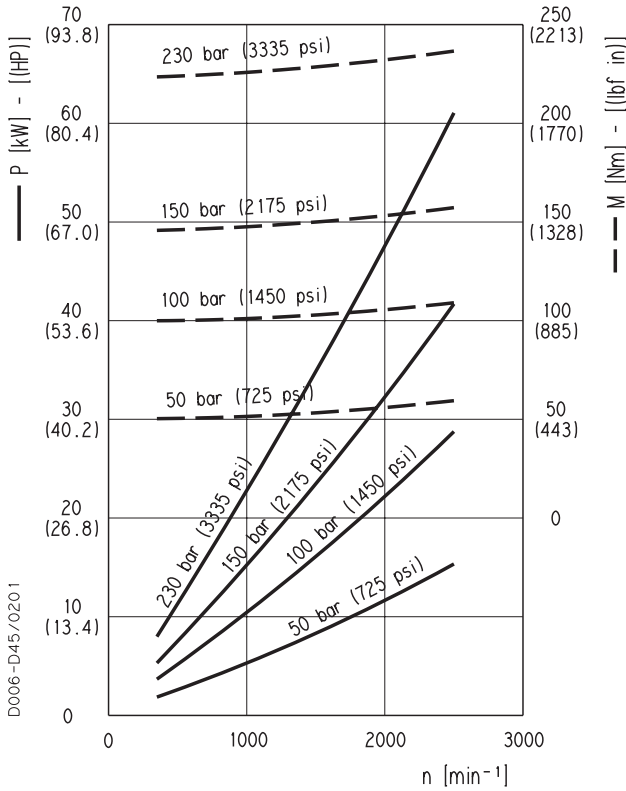

KP 30•56

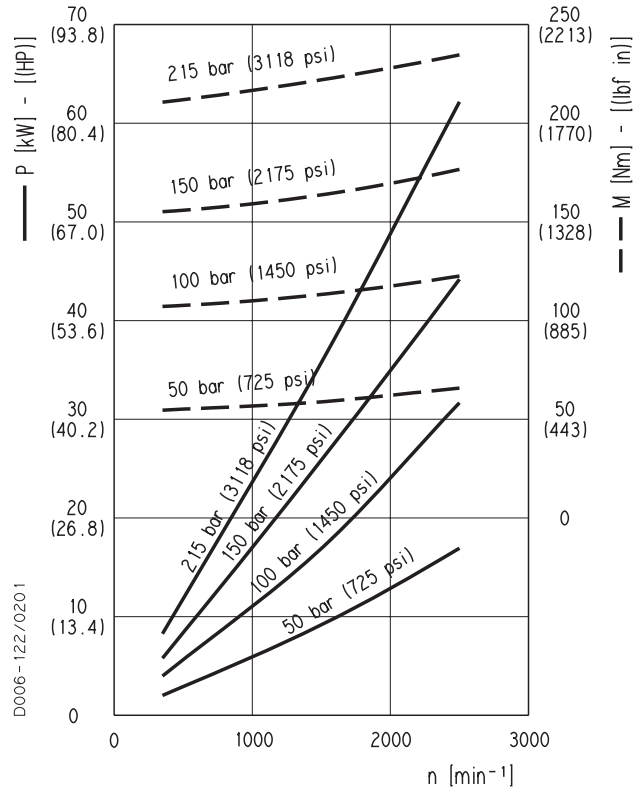

KP 30•61

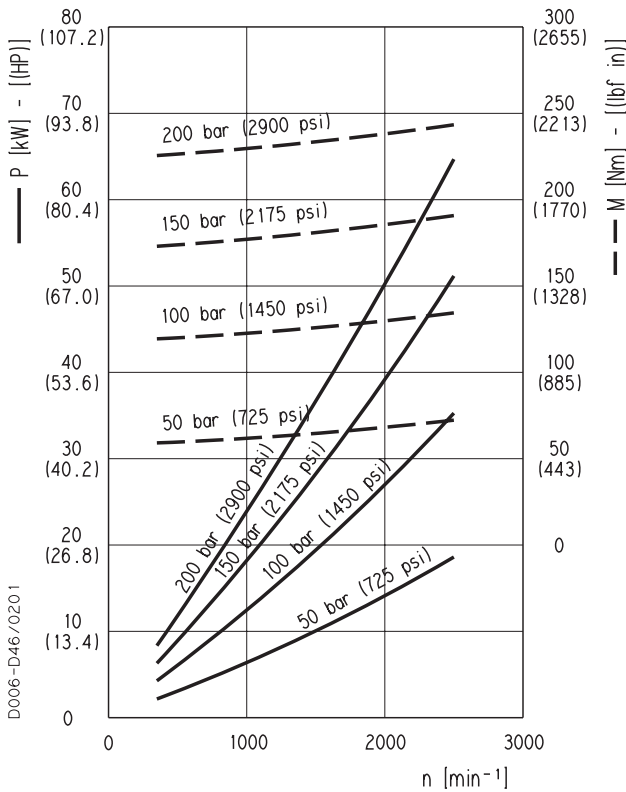

KP 30•73

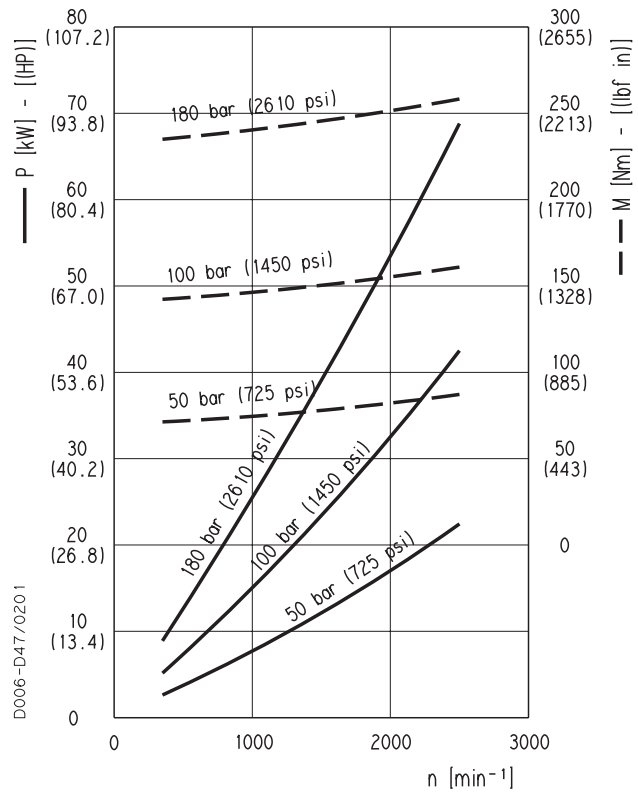

01/05.02

KAPPA 40 GEAR PUMPS PERFORMANCE CURVES

KP 40

KP 40

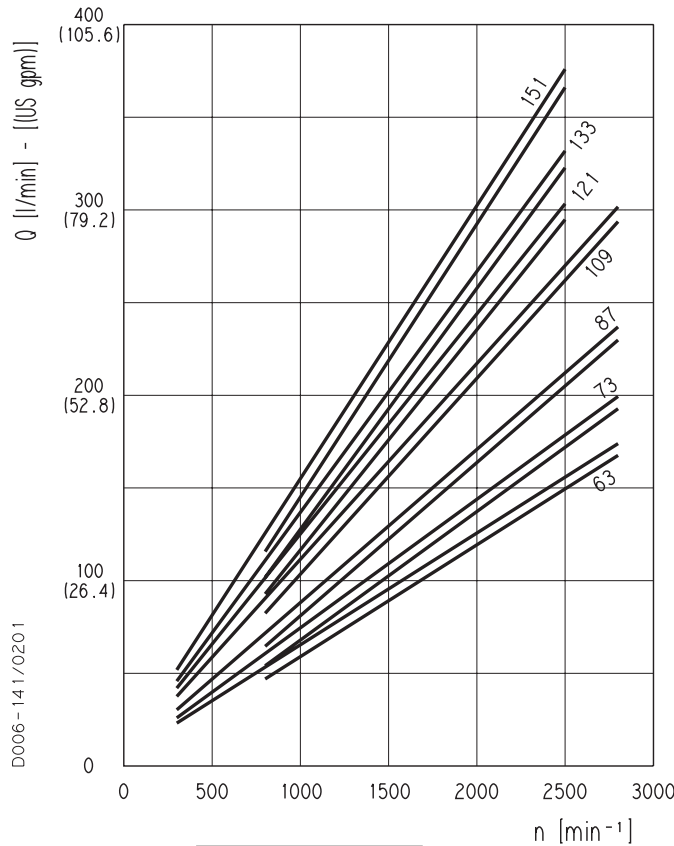

Each curve has been obtained at 122 °F (50°C), using oil with viscosity 168 SSU (36 cSt) at 104 °F (40°C) and at these pressures.

- KP 40•63 290-4350 psi (20-300 bar)
- KP 40•73 290-4350 psi (20-300 bar)
- KP 40•87 290-4060 psi (20-280 bar)
- KP 40•109 290-3625 psi (20-250 bar)
- KP 40•121 290-3335 psi (20-230 bar)
- KP 40•133 290-3190 psi (20-220 bar)
- KP 40•151 290-2900 psi (20-200 bar)

KP 40•63

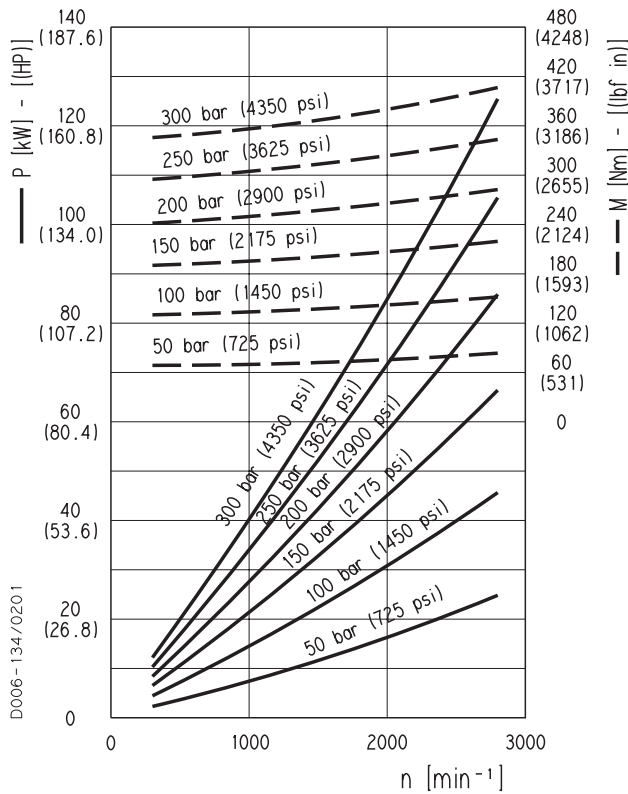

KP 40•73

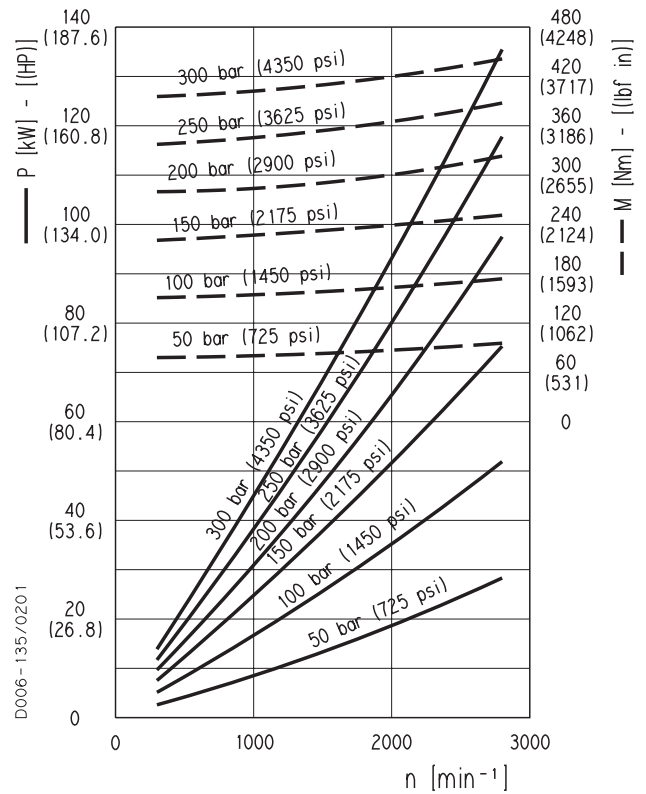

01/05.02

KAPPA 40 GEAR PUMPS PERFORMANCE CURVES

KP 40

KP 40•87

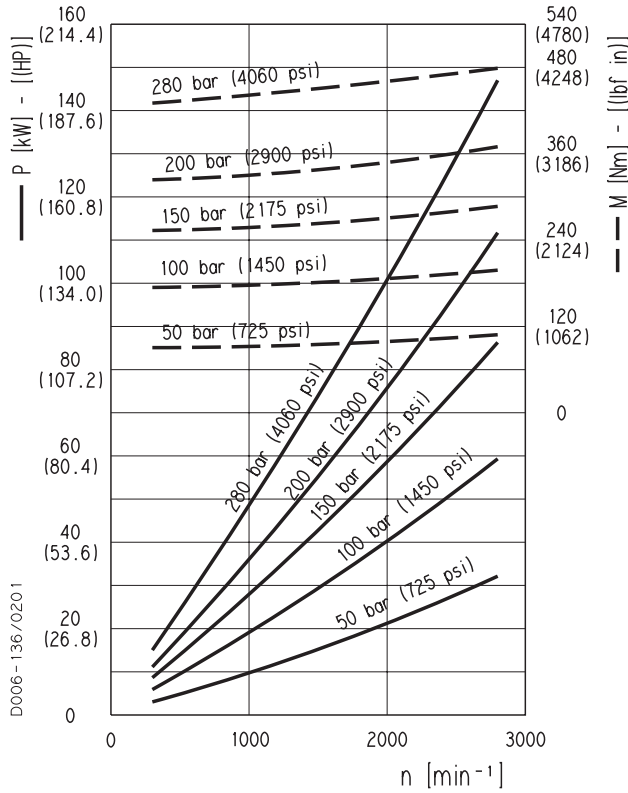

KP 40•109

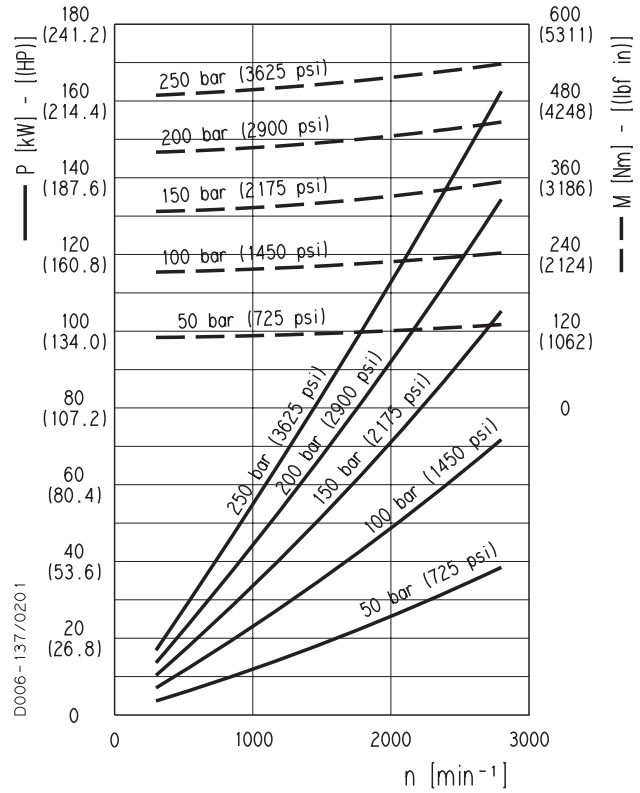

KP 40•121

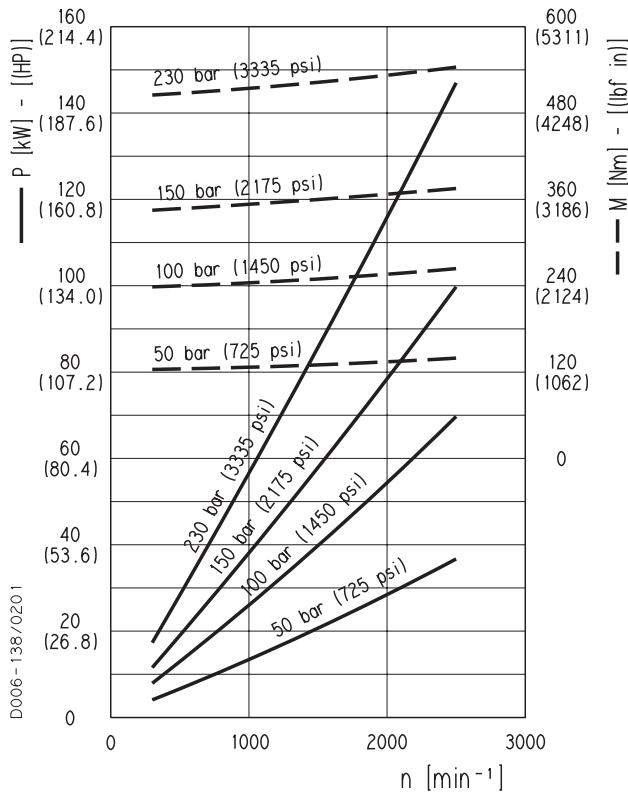

KP 40•133

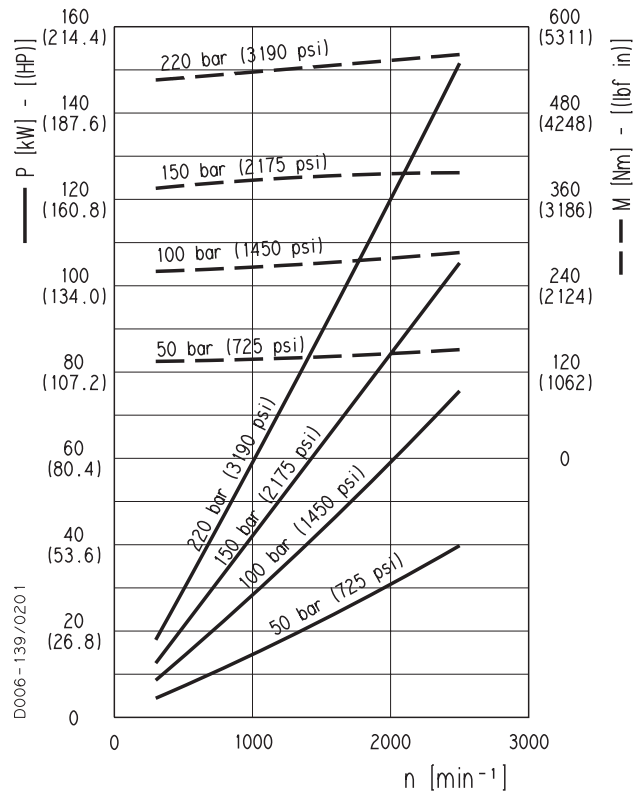

01/05.02

KAPPA 40 GEAR PUMPS PERFORMANCE CURVES

KP 40

KP 40-151

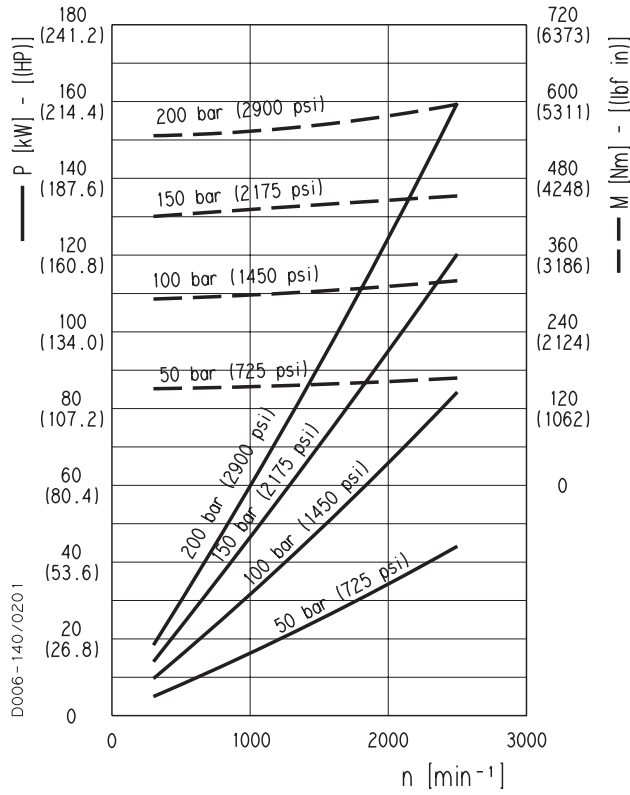

01/05.02

KAPPA 30 GEAR MOTORS PERFORMANCE CURVES

KM 30

KM 30

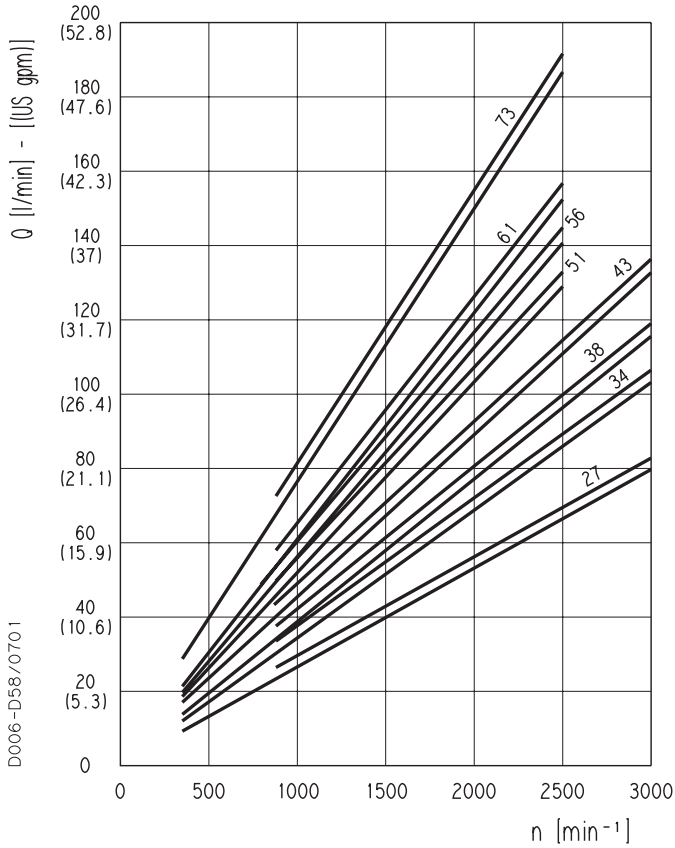

Each curve has been obtained at 122 °F (50°C), using oil with viscosity 168 SSU (36 cSt) at 104 °F (40°C) and at these pressures.

- KM 30•27 290-4060 psi (20-280 bar)
- KM 30•34 290-3770 psi (20-260 bar)
- KM 30•38 290-3770 psi (20-260 bar)
- KM 30•43 290-3625 psi (20-250 bar)
- KM 30•51 290-3335 psi (20-230 bar)
- KM 30•56 290-3118 psi (20-215 bar)
- KM 30•61 290-2900 psi (20-200 bar)
- KM 30•73 290-2610 psi (20-180 bar)

New displacements

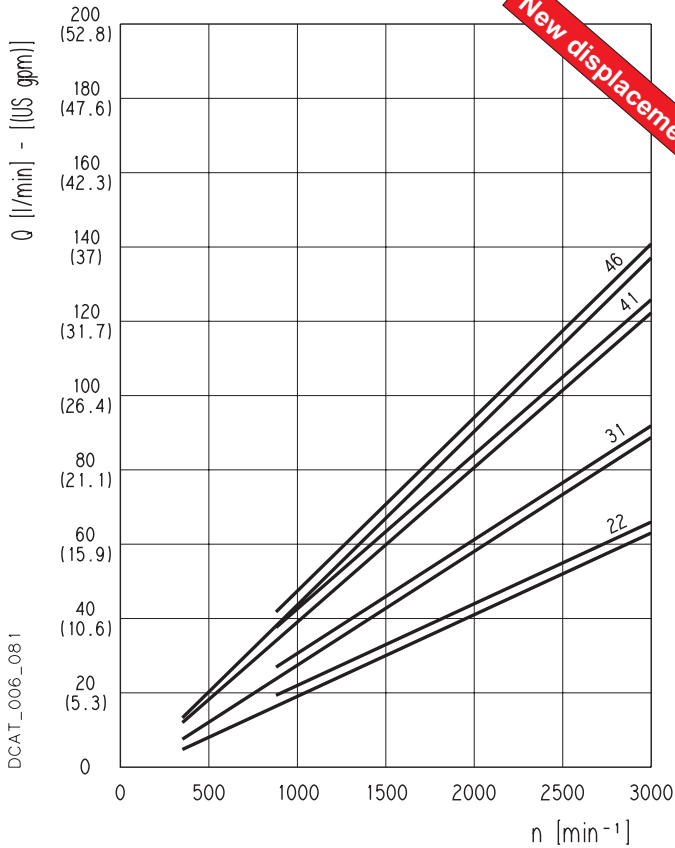

- KM 30•22 290-4060 psi (20-280 bar)
- KM 30•31 290-3770 psi (20-260 bar)
- KM 30•41 290-3625 psi (20-250 bar)
- KM 30•46 290-3625 psi (20-250 bar)

01/05.02

KAPPA 30 GEAR MOTORS PERFORMANCE CURVES

KM 30

KM 30-22

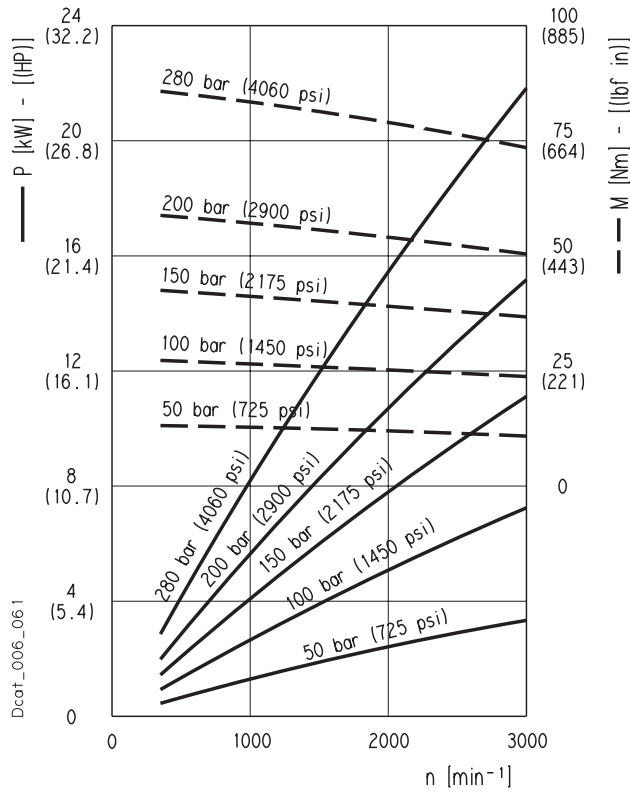

KM 30-27

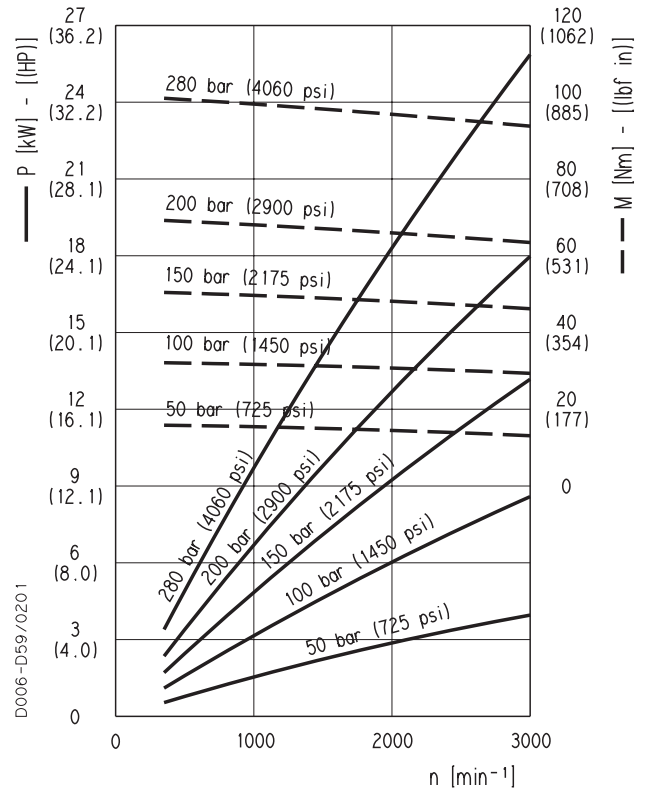

KM 30-31

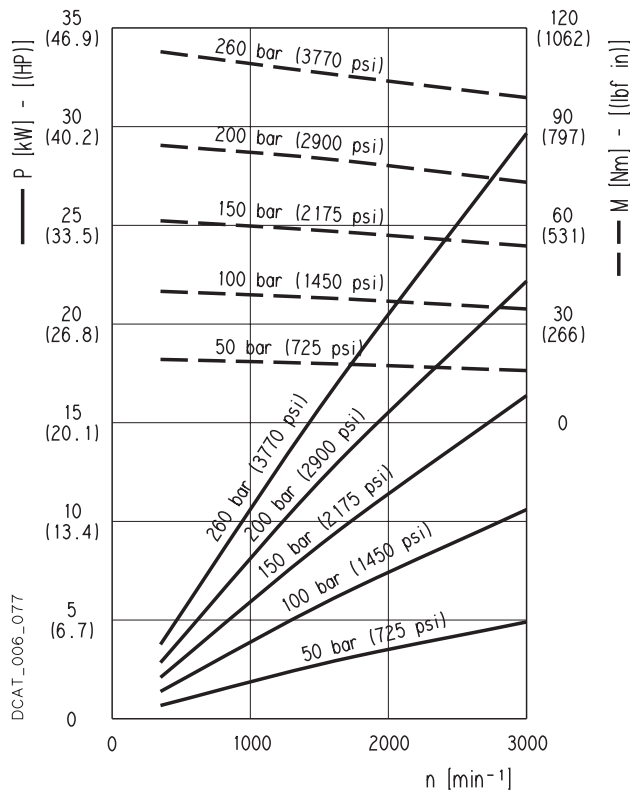

KM 30-34

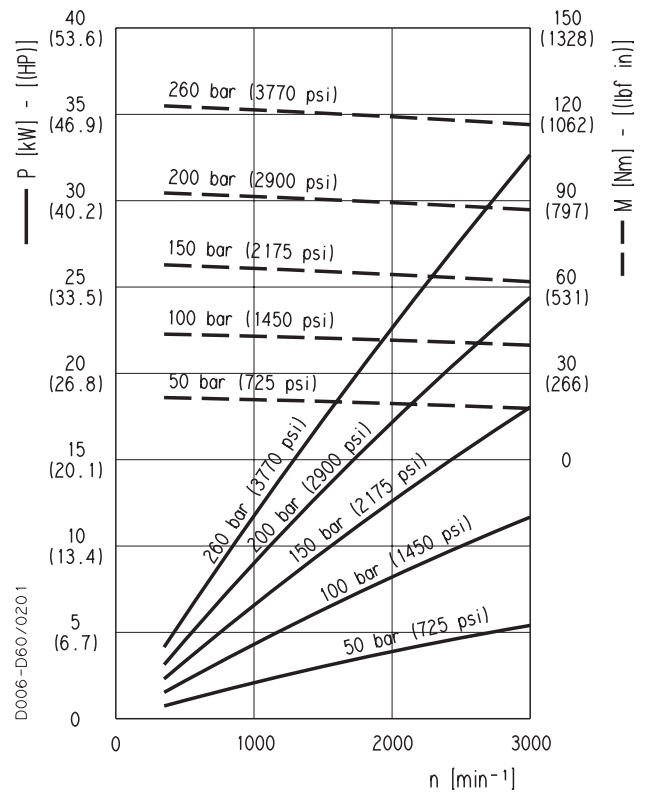

01/05.02

KAPPA 30 GEAR MOTORS PERFORMANCE CURVES

KM 30

KM 30-38

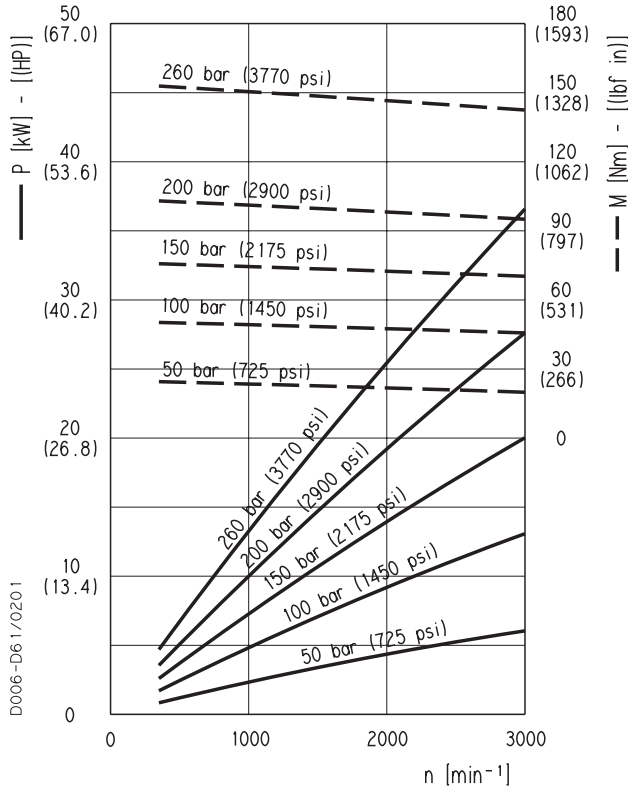

KM 30-41

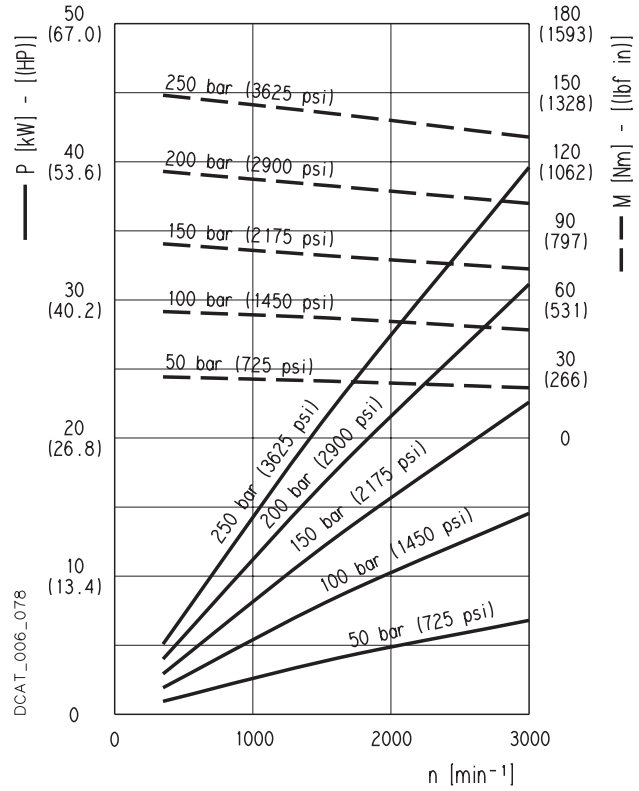

KM 30-43

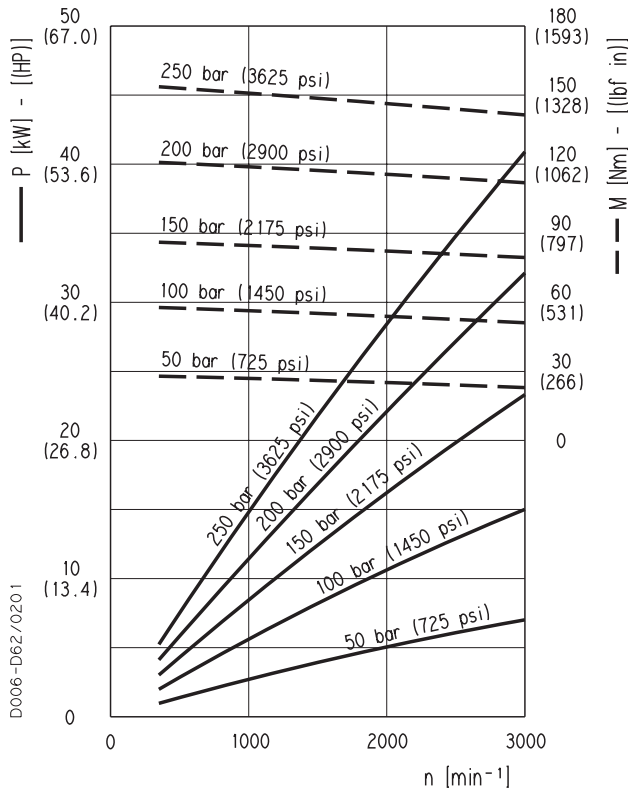

KM 30-46

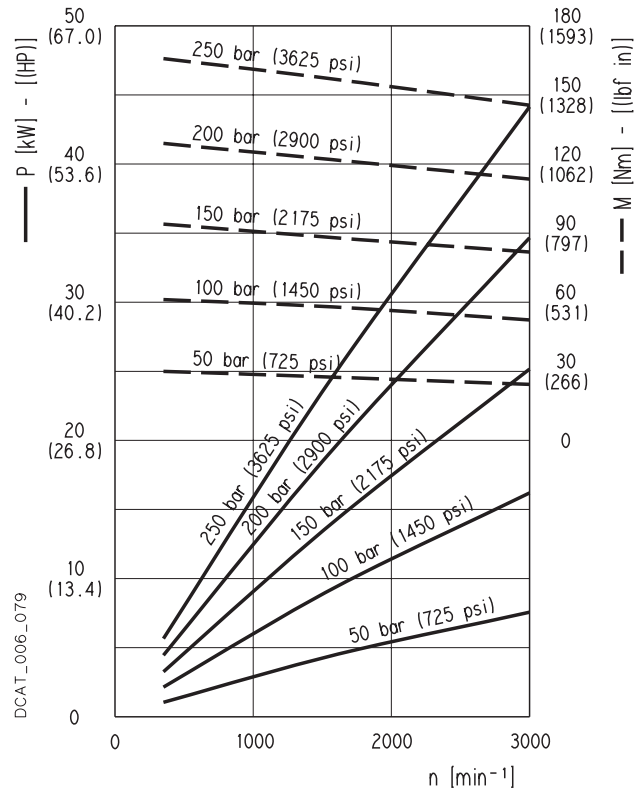

01/05.02

KAPPA 30 GEAR MOTORS PERFORMANCE CURVES

KM 30

KM 30-51

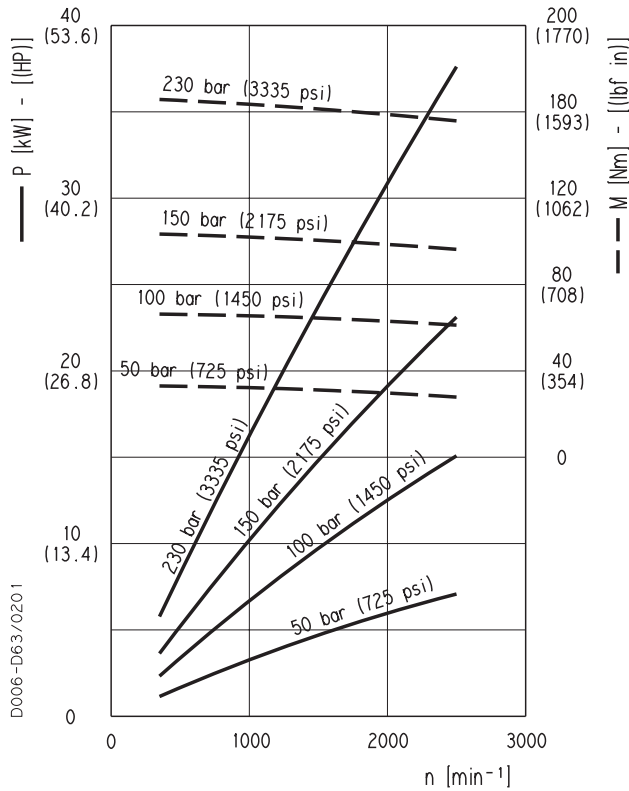

KM 30-56

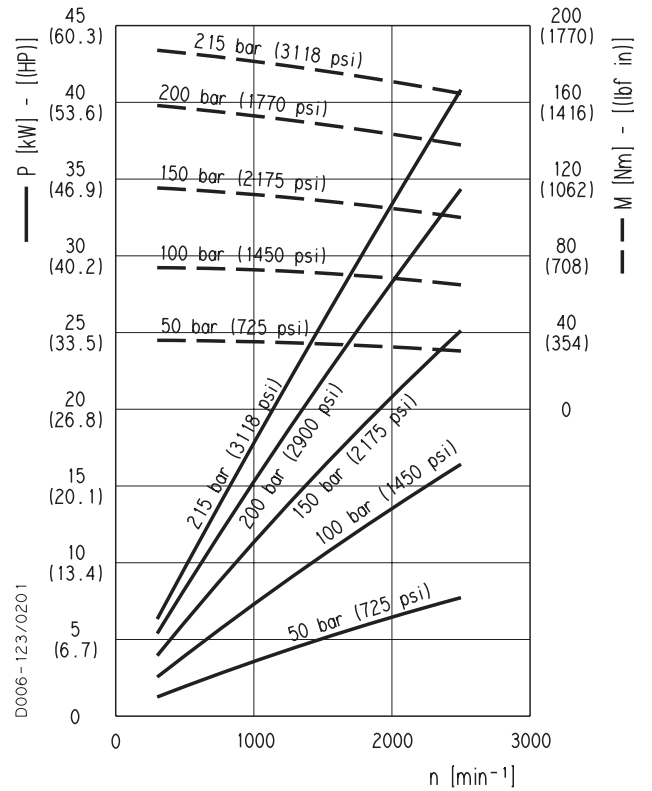

KM 30-61

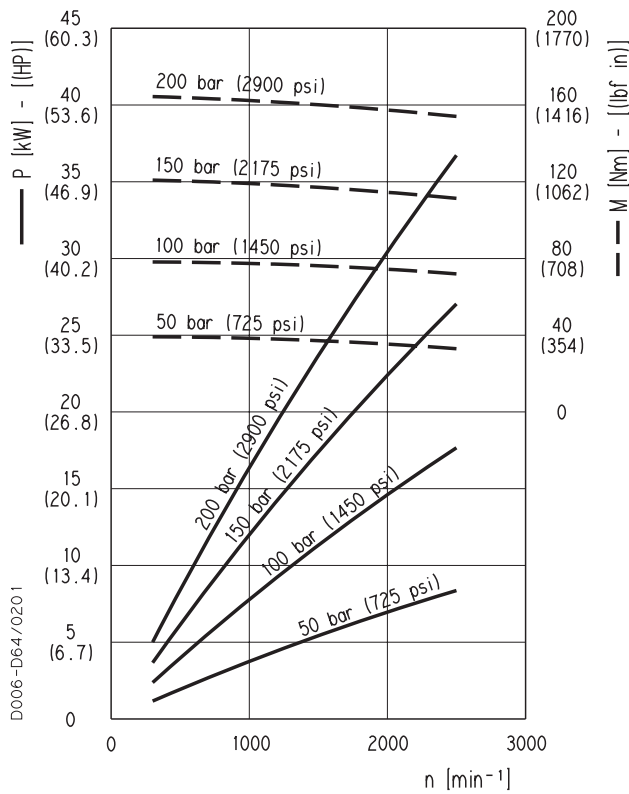

KM 30-73

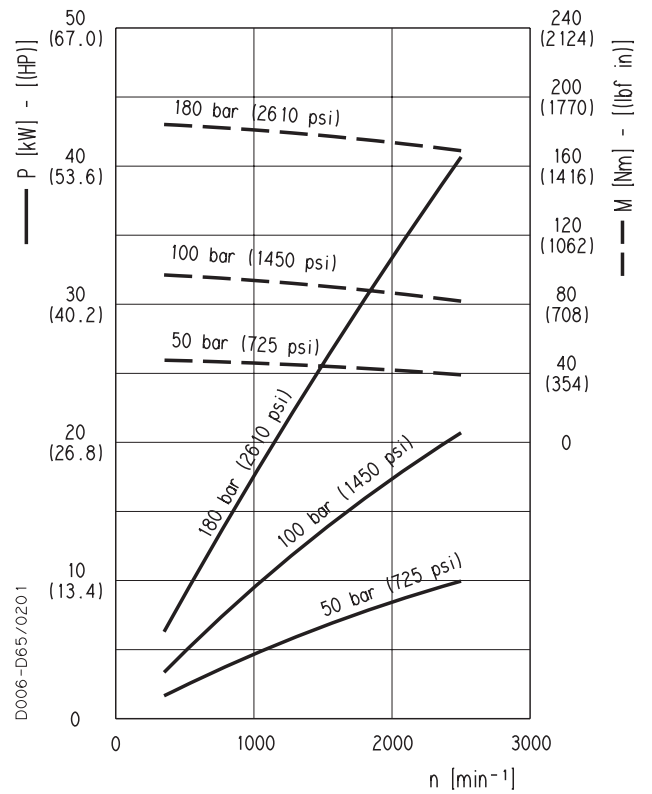

01/05.02

KAPPA 40 GEAR MOTORS PERFORMANCE CURVES

KM 40

KM 40

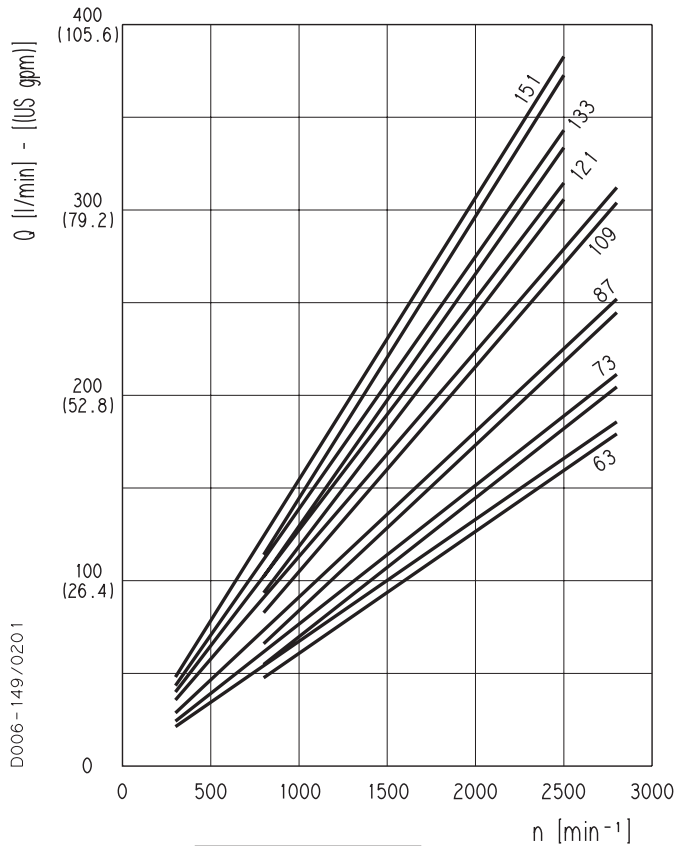

Each curve has been obtained at 122 °F (50°C), using oil with viscosity 168 SSU (36 cSt) at 104 °F (40°C) and at these pressures.

- KM 40•63 290-4350 psi (20-300 bar)
- KM 40•73 290-4350 psi (20-300 bar)
- KM 40•87 290-4060 psi (20-280 bar)
- KM 40•109 . . . 290-3625 psi (20-250 bar)
- KM 40•121 . . . 290-3335 psi (20-230 bar)
- KM 40•133 . . . 290-3190 psi (20-220 bar)
- KM 40•151 . . . 290-2900 psi (20-200 bar)

KM 40-63

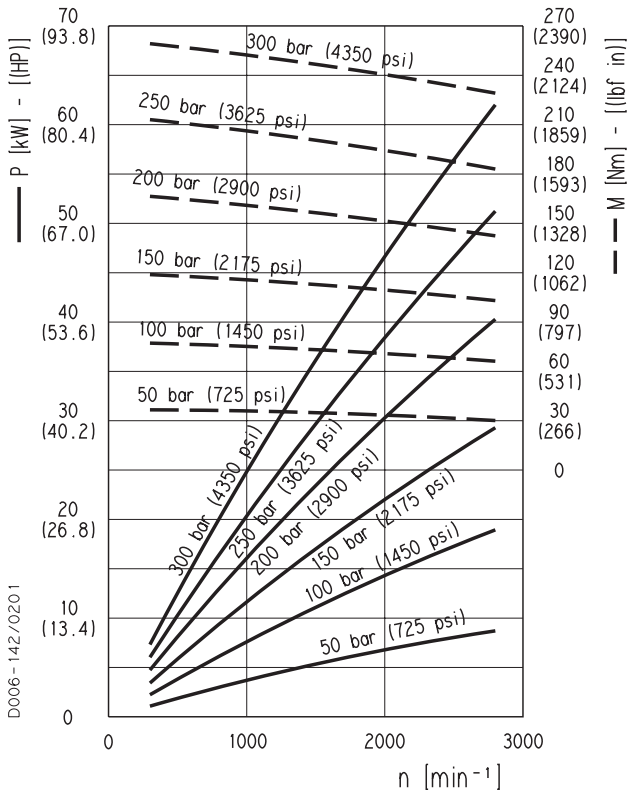

KM 40-73

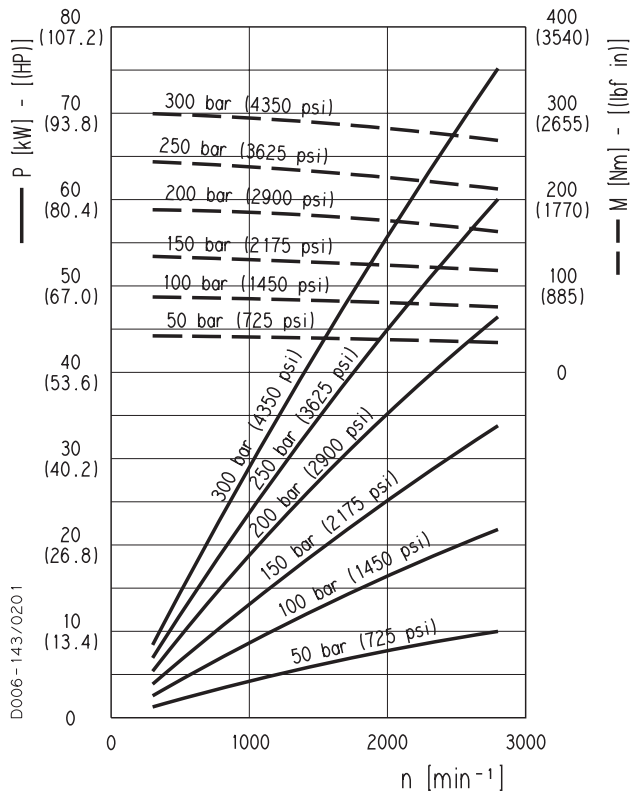

01/05.02

KAPPA 40 GEAR MOTORS PERFORMANCE CURVES

KM 40

KM 40-87

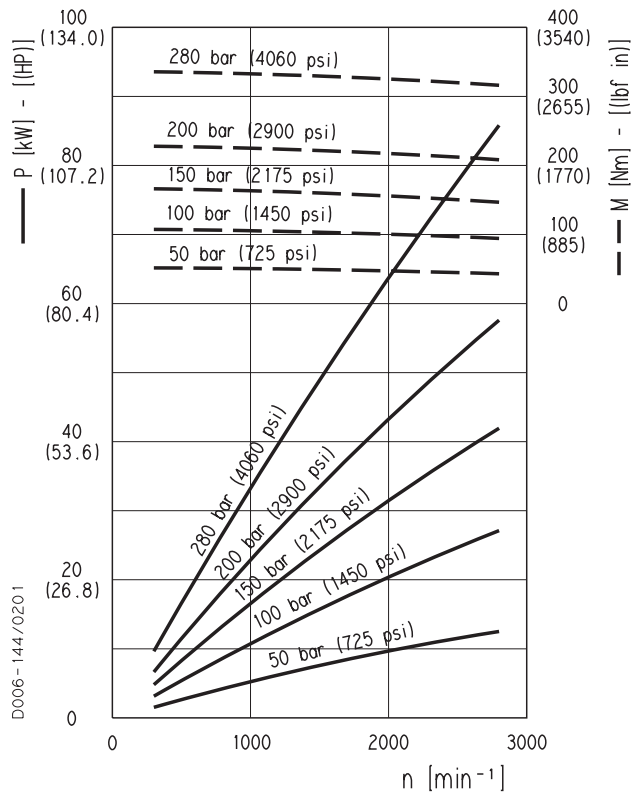

KM 40-109

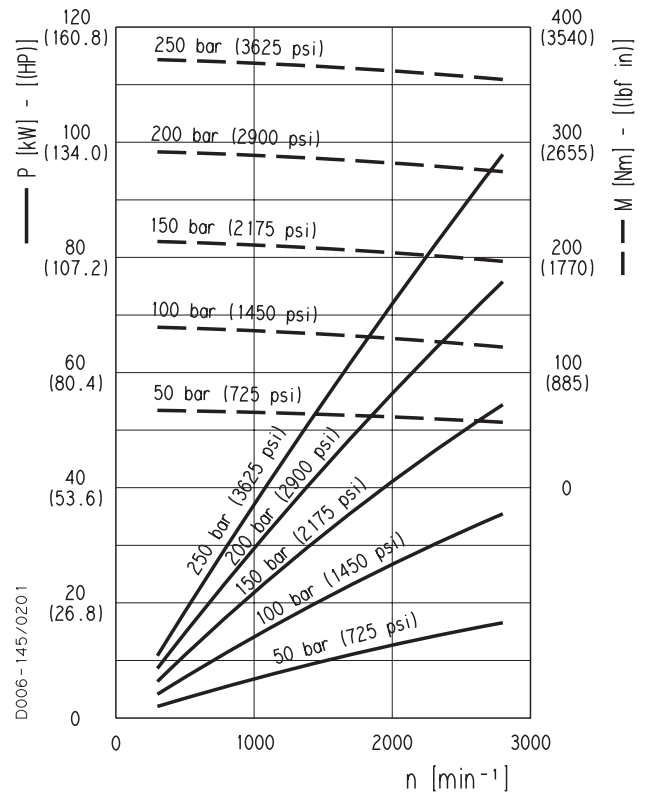

KM 40-121

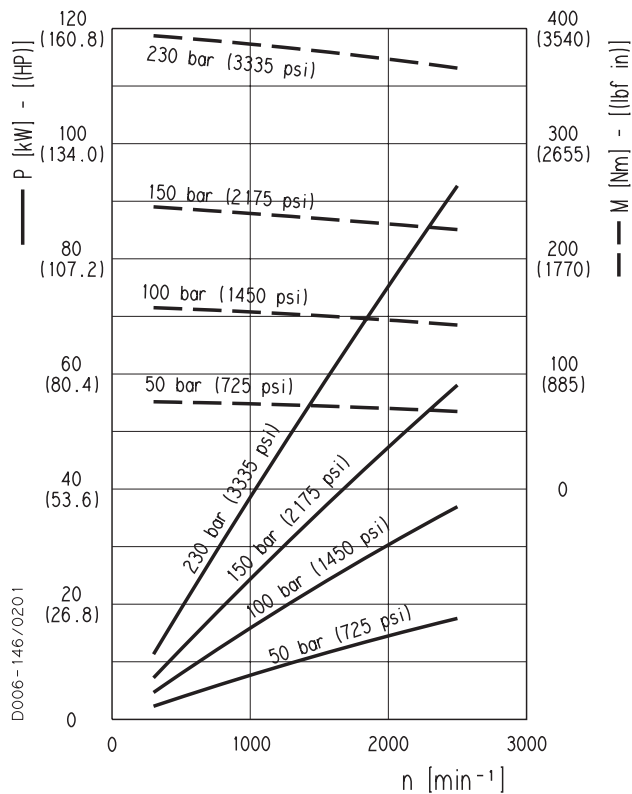

KM 40-133

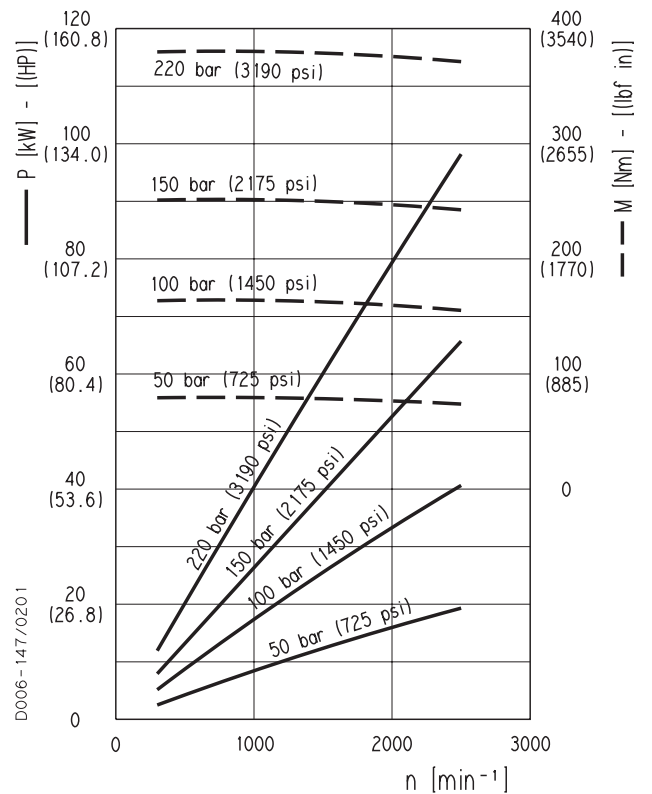

01/05.02

KAPPA 40 GEAR MOTORS PERFORMANCE CURVES

KM 40

KM 40-151

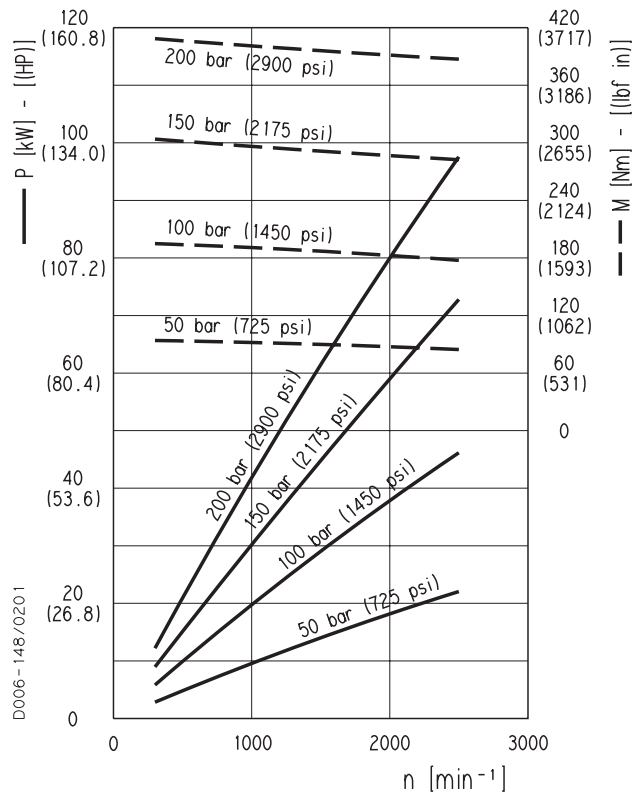

Replaces: 01/05.02

DCAT_006_007_03571388

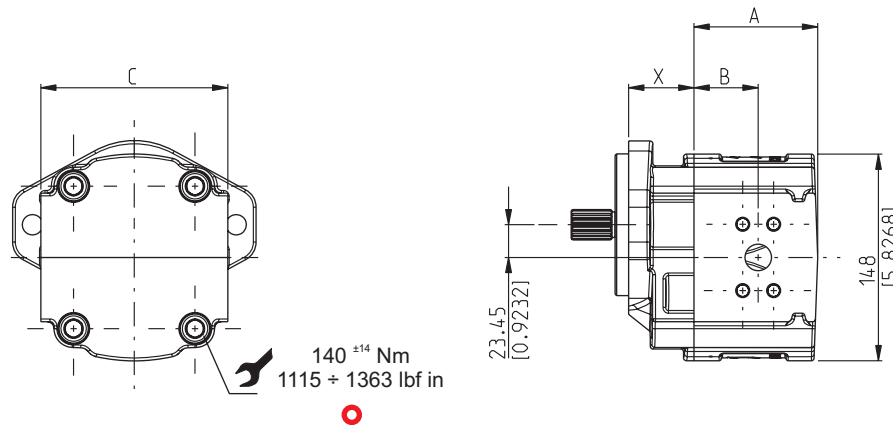

Ports type (see availability on page 47)			
European	Split (SSM) / (SSS)	Gas (BSPP)	SAE (ODT)

DRIVE SHAFTS:
see page 38 and page 39

MOUNTING FLANGE:
for X dimension see page 41 ÷ 45

Pump type Motor type	A	B	C	
			European ports Split ports (SSM) / (SSS)	Gas ports (BSPP) SAE ports (ODT)
	mm (inch)	mm (inch)	mm (inch)	mm (inch)
K. 30-22	80,5 (3.1693)	38 (1.4961)	134 (5.2756)	142,3 (5.6024)
K. 30-27	83,5 (3.2874)	41 (1.6142)	134 (5.2756)	142,3 (5.6024)
K. 30-31	86 (3.3858)	43,5 (1.7126)	134 (5.2756)	142,3 (5.6024)
K. 30-34	88,5 (3.4843)	46 (1.8110)	134 (5.2756)	142,3 (5.6024)
K. 30-38	91,5 (3.6024)	49 (1.9291)	134 (5.2756)	142,3 (5.6024)
K. 30-41	93 (3.6614)	50,5 (1.9882)	134 (5.2756)	142,3 (5.6024)
K. 30-43	94,5 (3.7205)	52 (2.0472)	134 (5.2756)	142,3 (5.6024)
K. 30-46	96 (3.7795)	53,5 (2.1063)	134 (5.2756)	142,3 (5.6024)
K. 30-51	99,5 (3.9173)	57 (2.2441)	134 (5.2756)	142,3 (5.6024)
K. 30-56	102,5 (4.0354)	60 (2.3622)	134 (5.2756)	142,3 (5.6024)
K. 30-61	105,5 (4.1535)	63 (2.4803)	134 (5.2756)	142,3 (5.6024)
K. 30-73	113,5 (4.4685)	71 (2.7953)	134 (5.2756)	142,3 (5.6024)

03/07.05

DCAT_006_008

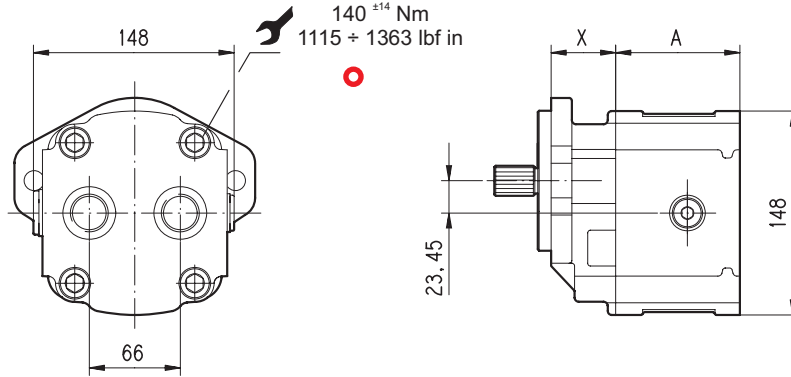

Replaces: 01/05.02

Ports type (see availability on page 47)	
Gas (BSPP)	SAE (ODT)

DRIVE SHAFTS:
see page 38 and page 39

MOUNTING FLANGE:
for X dimension see page 41 ÷ 45

Pump type Motor type	A
	mm (inch)
K. 30•22	76 (2.9921)
K. 30•27	79 (3.1102)
K. 30•31	81,5 (3.2087)
K. 30•34	84 (3.3071)
K. 30•38	87 (3.4252)
K. 30•41	88,5 (3.4843)
K. 30•43	90 (3.5433)
K. 30•46	91,5 (3.6024)
K. 30•51	95 (3.7401)
K. 30•56	98 (3.8583)
K. 30•61	101 (3.9764)
K. 30•73	109 (4.2913)

03/07.05

Replaces: 01/05.02

DCAT_006_006_PRT01137

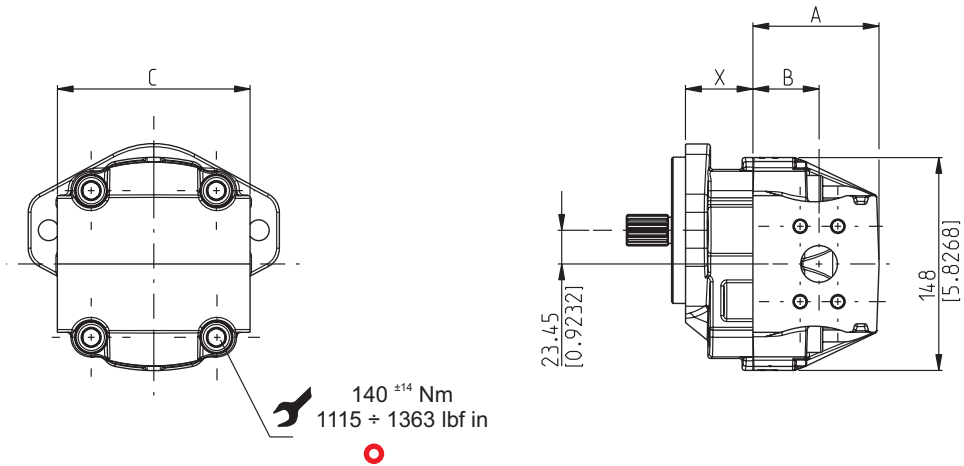

Ports type (see availability on page 47)			
European	Split (SSM) / (SSS)	Gas (BSPP)	SAE (ODT)

DRIVE SHAFTS:
see page 38 and page 39

MOUNTING FLANGE:
for X dimension see page 41 ÷ 45

Pump type Motor type	A	B	C	
			European ports Split ports (SSM) / (SSS)	Gas ports (BSPP) SAE ports (ODT)
	mm (inch)	mm (inch)	mm (inch)	mm (inch)
K. 30-22	80,5 (3.1693)	38 (1.4961)	134 (5.2756)	142 (5.5906)
K. 30-27	83,5 (3.2874)	41 (1.6142)	134 (5.2756)	142 (5.5906)
K. 30-31	86 (3.3858)	43,5 (1.7126)	134 (5.2756)	142 (5.5906)
K. 30-34	88,5 (3.4843)	46 (1.8110)	134 (5.2756)	142 (5.5906)
K. 30-38	88,5 (3.4843)	46 (1.8110)	134 (5.2756)	142 (5.5906)

03/07.05

DCAT_006_050_40_CSC

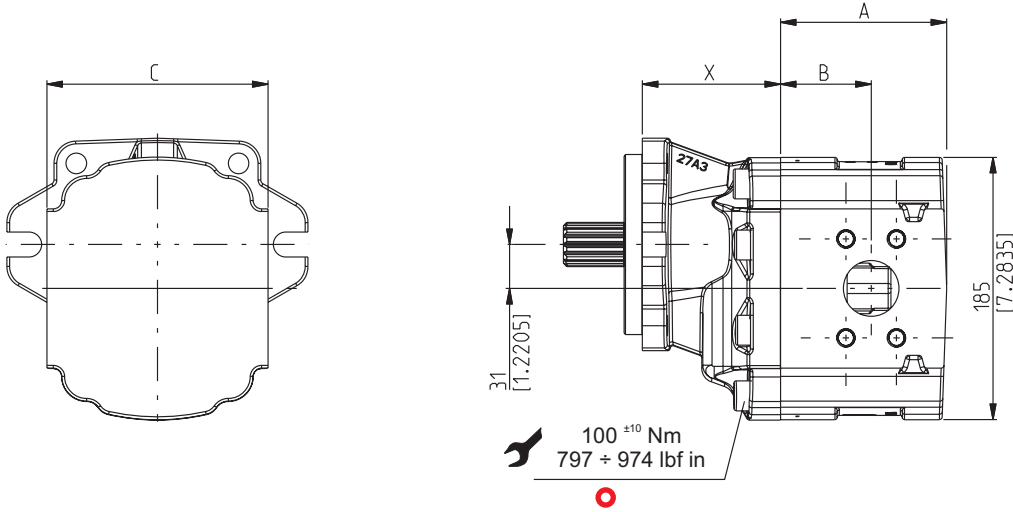

Replaces: 01/05.02

Ports type (see availability on page 47)			
European	Split (SSM) / (SSS)	Gas (BSPP)	SAE (ODT)

DRIVE SHAFTS:
see page 40

MOUNTING FLANGE:
for X dimension see page 46

Pump type Motor type	A	B	C	
			European ports Split ports (SSM) / (SSS)	Gas ports (BSPP) SAE ports (ODT)
	mm (inch)	mm (inch)	mm (inch)	mm (inch)
K. 40•63	108 (4.2610)	55 (2.1653)	156 (6.1417)	164 (6.4567)
K. 40•73	112 (4.4185)	59 (2.3228)	156 (6.1417)	164 (6.4567)
K. 40•87	117 (4.4094)	64 (2.5197)	156 (6.1417)	164 (6.4567)
K. 40•109	125 (4.9303)	63 (2.4403)	156 (6.1417)	164 (6.4567)
K. 40•121	130 (5.1272)	68 (2.6772)	156 (6.1417)	164 (6.4567)
K. 40•133	134 (5.2846)	72 (2.8346)	156 (6.1417)	164 (6.4567)
K. 40•151	140 (5.5209)	78 (3.0709)	156 (6.1417)	164 (6.4567)

03/07.05

DCAT_006_084_036300M6

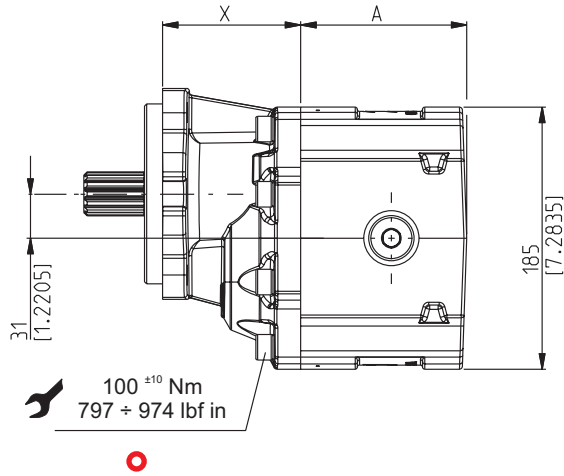
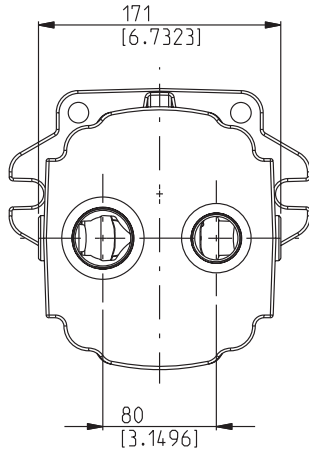

Ports type (see availability on page 47)	
Gas (BSPP)	SAE (ODT)

DRIVE SHAFTS:
see page 40

MOUNTING FLANGE:
for X dimension see page 46

Pump type Motor type	A	
	For rotation S - D - B (short body CSC)	For rotation R (long body CSL)
	mm (inch)	mm (inch)
K. 40-63	108 (4.2610)	124 (4.8819)
K. 40-73	112 (4.4185)	128 (5.0394)
K. 40-87	117 (4.4094)	133 (5.2362)
K. 40-109	125 (4.9303)	141 (5.5512)
K. 40-121	130 (5.1272)	146 (5.7480)
K. 40-133	134 (5.2846)	150 (5.9055)
K. 40-151	140 (5.5209)	156 (6.1417)

03/07.05

MULTIPLE PUMPS

KAPPA series pumps can be coupled together in combination. In applications where the input power requirement of each section varies, the section with the greater requirement must be at the drive shaft end, and progressively smaller to the rear.

Features and performances are the same as the corresponding single pumps, but pressures must be limited by the transmissible torque of the drive and connecting shafts. To have appropriate data, use the formula below.

The maximum rotational speed is that of the lowest rated speed of the single units incorporated.

Available with common inlet. For more information please consult our technical sales department.

M	lbf in (Nm)	Torque
V	in ³ /rev (cm ³ /rev)	Displacement
Δp	psi (bar)	Pressure
P	HP (kW)	Power
n	min ⁻¹	Speed
○	$\eta_m = \eta_m(V, \Delta p, n) \quad (\approx 0,90)$	Mechanical efficiency

$$M = \frac{\Delta p \text{ (bar)} \cdot V \text{ (cm}^3\text{/rev)}}{62,83 \cdot \eta_m} \quad [\text{Nm}]$$

$$M = \frac{P \text{ (HP)} \cdot 5252}{n \text{ (min}^{-1}\text{)} \cdot \eta_m} \quad [\text{lbf in}]$$

Note: The torque absorbed from the shaft of the first pump results from the sum of the torques due to all single stages. The achieved value must not exceed the maximum torque limit given for the shaft of the first pump. Diagrams providing approximate selection data will be found on page 25.

ABSORBED TORQUE

Replaces: 01/05.02

KP 40 1

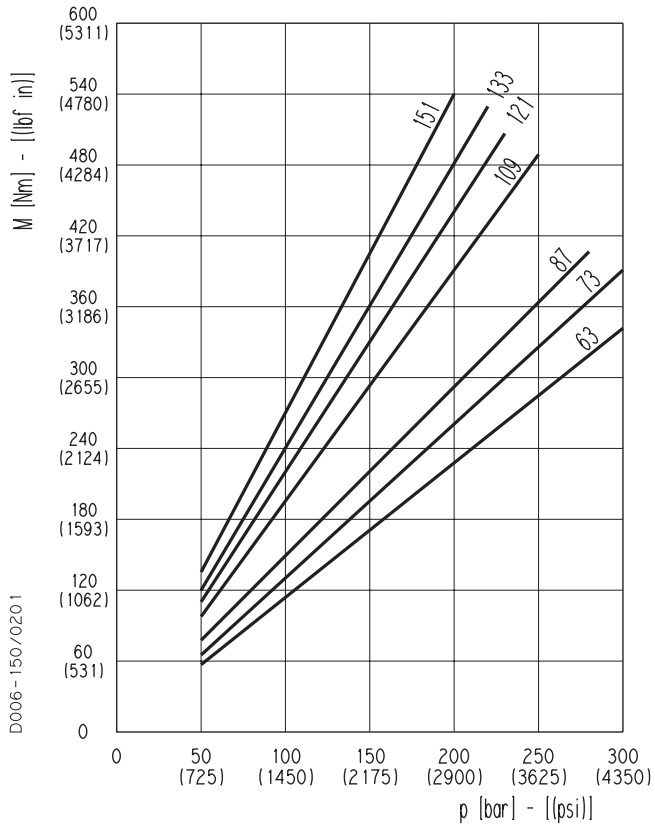

KP 30 2

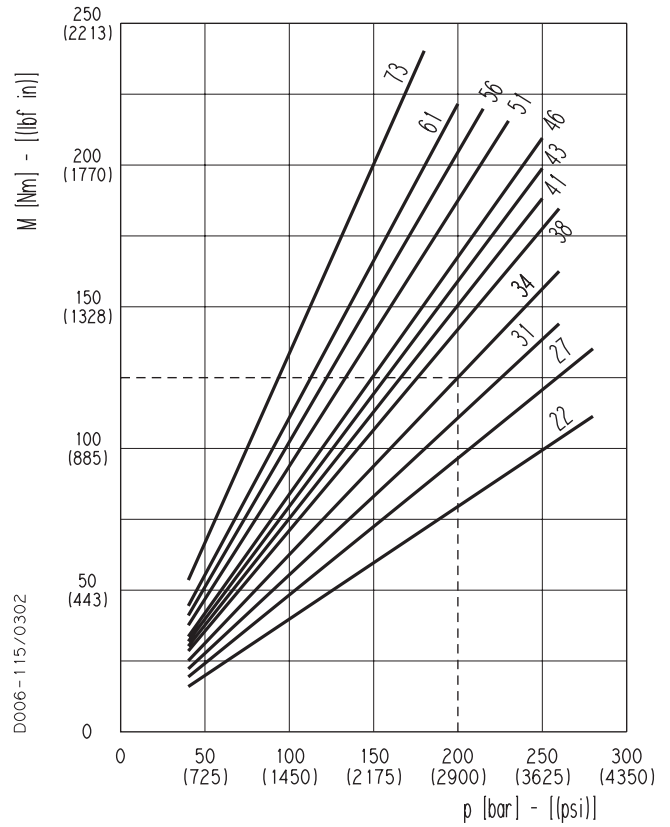

KP 20 - PLP 20 3

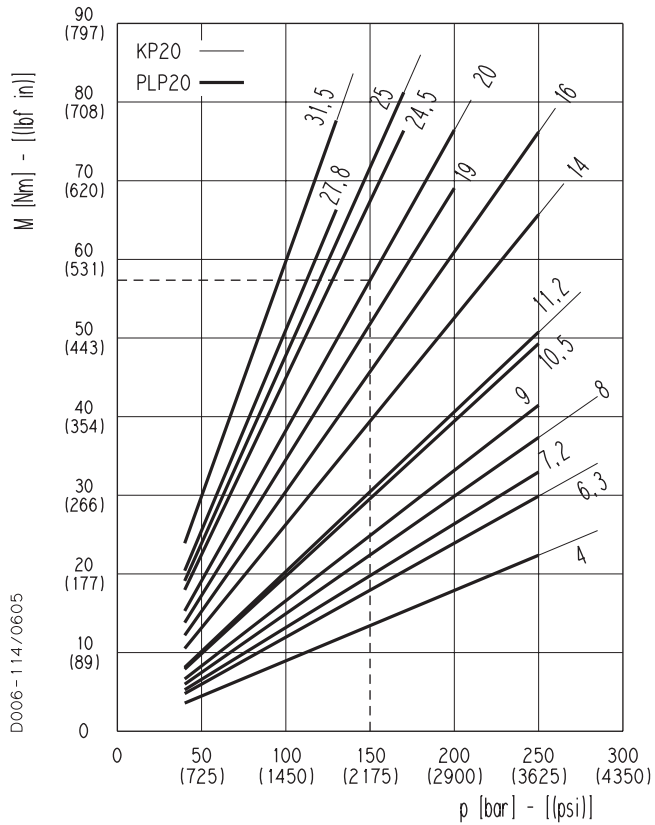

03/07.05

DRIVE SHAFT SELECTION

Let us consider a double pump KP30•34+ PL20•20. If we suppose that we have to work with the first pump at a pressure of 2900 psi (200 bar) and the second pump at a pressure of 2175 psi (150 bar), the graph 2 shows that the torque absorbed by KP30•34 is 1106 lbf in (125 Nm) and the graph 3 shows that the torque absorbed by KP20•20 is 487 lbf in (55 Nm) [acceptable value because it doesn't exceed the maximum drive shaft torque that is 974 lbf in (110 Nm), see page 30]. The torque to be transmitted by the first drive shaft will thus be 1106+487=1593 lbf in (125+55=180 Nm), this value must not exceed the shaft's maximum rated value.

KAPPA 30

MULTIPLE PUMPS SAME GROUPS

CS.

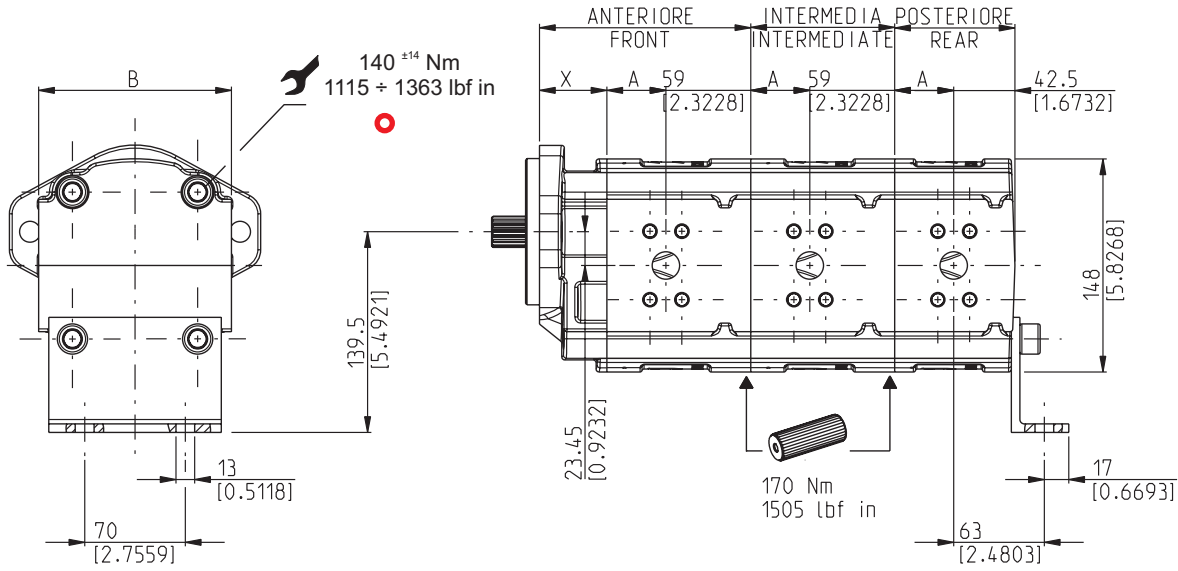

DCAT_006_031_S1080

Replaces: 01/05.02

Ports type (see availability on page 47)			
European	Split (SSM) / (SSS)	Gas (BSPP)	SAE (ODT)

DRIVE SHAFTS:
see page 38 and page 39

MOUNTING FLANGE:
for X dimension see page 41 ÷ 45

FRONT: CSL (long body)
INTERMEDIATE: CSL (long body)
REAR: CSC (short body)
 (all multiple pumps with more than two sections are available with bracket).

Pump type	B		
	A	European ports Split ports (SSM/SSS)	Gas ports (BSPP) SAE ports (ODT)
	mm (inch)	mm (inch)	mm (inch)
KP 30-22	38 (1.4961)	134 (5.2756)	142,3 (5.6024)
KP 30-27	41 (1.6142)	134 (5.2756)	142,3 (5.6024)
KP 30-31	43,5 (1.7126)	134 (5.2756)	142,3 (5.6024)
KP 30-34	46 (1.8110)	134 (5.2756)	142,3 (5.6024)
KP 30-38	49 (1.9291)	134 (5.2756)	142,3 (5.6024)
KP 30-41	50,5 (1.9882)	134 (5.2756)	142,3 (5.6024)
KP 30-43	52 (2.0472)	134 (5.2756)	142,3 (5.6024)
KP 30-46	53,5 (2.1063)	134 (5.2756)	142,3 (5.6024)
KP 30-51	57 (2.2441)	134 (5.2756)	142,3 (5.6024)
KP 30-56	60 (2.3622)	134 (5.2756)	142,3 (5.6024)
KP 30-61	63 (2.4803)	134 (5.2756)	142,3 (5.6024)
KP 30-73	71 (2.7953)	134 (5.2756)	142,3 (5.6024)

03/07.05

Replaces: 01/05.02

DCAT_006_034_R11179

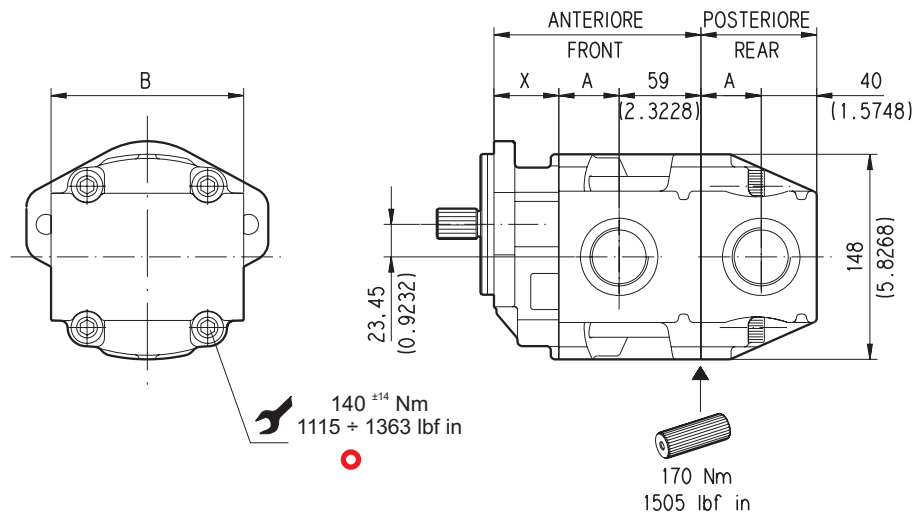

Ports type (see availability on page 47)			
European	Split (SSM) / (SSS)	Gas (BSPP)	SAE (ODT)

DRIVE SHAFTS:
see page 38 and page 39

MOUNTING FLANGE:
for X dimension see page 41 ÷ 45

FRONT: **KSL** (long shaped body)
REAR: **KSC** (short shaped body)

03/07.05

Pump type	A	B	
		European ports Split ports (SSM/SSS)	Gas ports (BSPP) SAE ports (ODT)
	mm (inch)	mm (inch)	mm (inch)
KP 30•22	38 (1.4961)	134 (5.2756)	142,3 (5.6024)
KP 30•27	41 (1.6142)	134 (5.2756)	142,3 (5.6024)
KP 30•31	43,5 (1.7126)	134 (5.2756)	142,3 (5.6024)
KP 30•34	46 (1.8110)	134 (5.2756)	142,3 (5.6024)
KP 30•38	46 (1.8110)	134 (5.2756)	142,3 (5.6024)

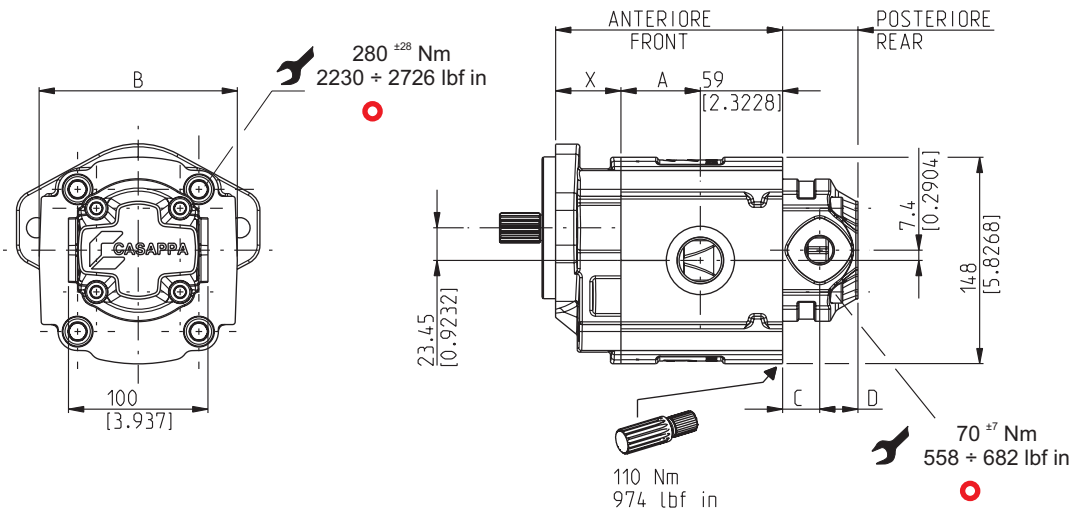

DCAT_006_032_S1081

Replaces: 01/05.02

Ports type (see availability on page 47)			
European	Split (SSM) / (SSS)	Gas (BSPP)	SAE (ODT)

DRIVE SHAFTS:
see page 38 and page 39

MOUNTING FLANGE:
for X dimension see page 41 ÷ 45

FRONT: **CSL** (long body)
REAR: Kappa 20 Series (for features please consult the proper technical catalog)

Pump type	A	B	
		European ports Split ports (SSM/SSS)	Gas ports (BSPP) SAE ports (ODT)
	mm (inch)	mm (inch)	mm (inch)
KP 30-22	38 (1.4961)	134 (5.2756)	142 (5.5906)
KP 30-27	41 (1.6142)	134 (5.2756)	142 (5.5906)
KP 30-31	43,5 (1.7126)	134 (5.2756)	142 (5.5906)
KP 30-34	46 (1.8110)	134 (5.2756)	142 (5.5906)
KP 30-38	49 (1.9291)	134 (5.2756)	142 (5.5906)
KP 30-41	50,5 (1.9882)	134 (5.2756)	142 (5.5906)
KP 30-43	52 (2.0472)	134 (5.2756)	142 (5.5906)
KP 30-46	53,5 (2.1063)	134 (5.2756)	142 (5.5906)
KP 30-51	57 (2.2441)	134 (5.2756)	142 (5.5906)
KP 30-56	60 (2.3622)	134 (5.2756)	142 (5.5906)
KP 30-61	63 (2.4803)	134 (5.2756)	142 (5.5906)
KP 30-73	71 (2.7953)	134 (5.2756)	142 (5.5906)

Pump type	C	D
	mm (inch)	mm (inch)
KP 20-4	24 (0.9449)	27,5 (1.0827)
KP 20-6,3	26,5 (1.0433)	27,5 (1.0827)
KP 20-8	29 (1.1417)	27,5 (1.0827)
KP 20-11,2	32,5 (1.2795)	27,5 (1.0827)
KP 20-14	31 (1.2205)	33 (1.2992)
KP 20-16	36,5 (1.4370)	33 (1.2992)
KP 20-20	43 (1.6929)	33 (1.2992)
KP 20-25	36 (1.4173)	48 (1.8898)
KP 20-31,5	46 (1.8110)	48 (1.8898)

03/07.05

KAPPA 30

DOUBLE PUMPS KP30/PL20 SHORT BODY

CSC

Replaces: 01/05.02

DCAT_006_033_S1082

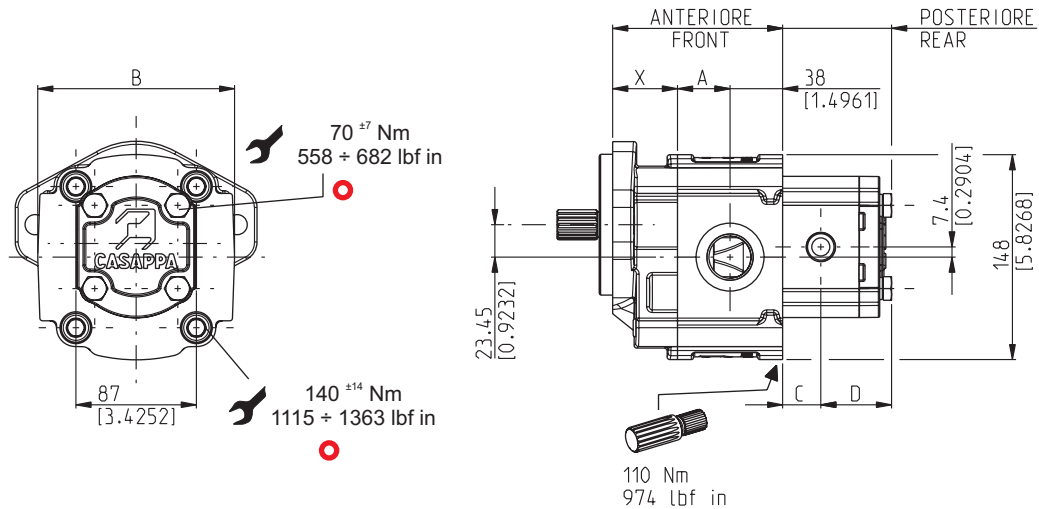

Ports type (see availability on page 47)			
European	Split (SSM) / (SSS)	Gas (BSPP)	SAE (ODT)

DRIVE SHAFTS:
see page 38 and page 39

MOUNTING FLANGE:
for X dimension see page 41 ÷ 45

FRONT: **CSC** (short body)
REAR: Polaris 20 Series (for features please consult the proper technical catalog)

Pump type	A	B	
		European ports Split ports (SSM/SSS)	Gas ports (BSPP) SAE ports (ODT)
	mm (inch)	mm (inch)	mm (inch)
KP 30•22	38 (1.4961)	134 (5.2756)	142 (5.5906)
KP 30•27	41 (1.6142)	134 (5.2756)	142 (5.5906)
KP 30•31	43,5 (1.7126)	134 (5.2756)	142 (5.5906)
KP 30•34	46 (1.8110)	134 (5.2756)	142 (5.5906)
KP 30•38	49 (1.9291)	134 (5.2756)	142 (5.5906)
KP 30•41	50,5 (1.9882)	134 (5.2756)	142 (5.5906)
KP 30•43	52 (2.0472)	134 (5.2756)	142 (5.5906)
KP 30•46	53,5 (2.1063)	134 (5.2756)	142 (5.5906)
KP 30•51	57 (2.2441)	134 (5.2756)	142 (5.5906)
KP 30•56	60 (2.3622)	134 (5.2756)	142 (5.5906)
KP 30•61	63 (2.4803)	134 (5.2756)	142 (5.5906)
KP 30•73	71 (2.7953)	134 (5.2756)	142 (5.5906)

Pump type	B	C
	mm (inch)	mm (inch)
PLP 20•4	25,8 (1.0157)	49,3 (1.9409)
PLP 20•6,3	27 (1.0630)	50,5 (1.9882)
PLP 20•7,2	27,5 (1.0826)	51 (2.0079)
PLP 20•8	28,3 (1.1142)	51,8 (2.0394)
PLP 20•9	28,9 (1.1378)	52,4 (2.0630)
PLP 20•10,5	30,3 (1.1929)	53,8 (2.1181)
PLP 20•11,2	30,5 (1.2008)	54 (2.1260)
PLP 20•14	33 (1.2992)	56,5 (2.2244)
PLP 20•16	34,8 (1.3701)	58,3 (2.2953)
PLP 20•19	36,5 (1.4370)	60 (2.3622)
PLP 20•20	38 (1.4961)	61,5 (2.4213)
PLP 20•24,5	40,8 (1.6063)	64,3 (2.5315)
PLP 20•25	42 (1.6535)	65,5 (2.5787)
PLP 20•27,5	43,4 (1.7087)	66,9 (2.6339)
PLP 20•31,5	47 (1.8504)	70,5 (2.7756)

03/07.05

KAPPA 30

DOUBLE PUMPS KP30/PL20 SHORT SHAPED BODY

HSC

DCAT_006_059_N16-2

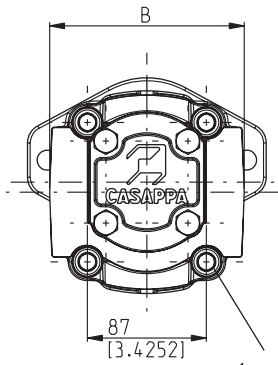

140 ^{#14} Nm
1115 ÷ 1363 lbf in

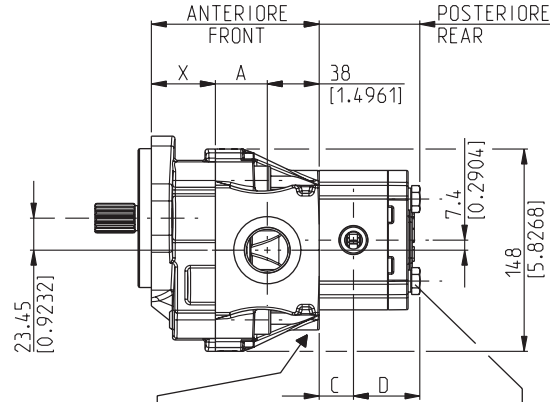

110 Nm
974 lbf in

70 ^{#7} Nm
558 ÷ 682 lbf in

Replaces: 01/05.02

Ports type (see availability on page 47)			
European	Split (SSM) / (SSS)	Gas (BSPP)	SAE (ODT)

DRIVE SHAFTS:
see page 38 and page 39

MOUNTING FLANGE:
for X dimension see page 41 ÷ 45

FRONT: **HSC** (short shaped body)
REAR: Polaris 20 Series (for features please consult the proper technical catalog)

Pump type	A	B	
		European ports Split ports (SSM/SSS)	Gas ports (BSPP) SAE ports (ODT)
	mm (inch)	mm (inch)	mm (inch)
KP 30-22	38 (1.4961)	134 (5.2756)	142,3 (5.6024)
KP 30-27	41 (1.6142)	134 (5.2756)	142,3 (5.6024)
KP 30-31	43,5 (1.7126)	134 (5.2756)	142,3 (5.6024)
KP 30-34	46 (1.8110)	134 (5.2756)	142,3 (5.6024)
KP 30-38	46 (1.8110)	134 (5.2756)	142,3 (5.6024)

Pump type	B	C
	mm (inch)	mm (inch)
PLP 20-4	25,8 (1.0157)	49,3 (1.9409)
PLP 20-6,3	27 (1.0630)	50,5 (1.9882)
PLP 20-7,2	27,5 (1.0826)	51 (2.0079)
PLP 20-8	28,3 (1.1142)	51,8 (2.0394)
PLP 20-9	28,9 (1.1378)	52,4 (2.0630)
PLP 20-10,5	30,3 (1.1929)	53,8 (2.1181)
PLP 20-11,2	30,5 (1.2008)	54 (2.1260)
PLP 20-14	33 (1.2992)	56,5 (2.2244)
PLP 20-16	34,8 (1.3701)	58,3 (2.2953)
PLP 20-19	36,5 (1.4370)	60 (2.3622)
PLP 20-20	38 (1.4961)	61,5 (2.4213)
PLP 20-24,5	40,8 (1.6063)	64,3 (2.5315)
PLP 20-25	42 (1.6535)	65,5 (2.5787)
PLP 20-27,5	43,4 (1.7087)	66,9 (2.6339)
PLP 20-31,5	47 (1.8504)	70,5 (2.7756)

03/07.05

KAPPA 40

MULTIPLE PUMPS SAME GROUPS

CS.

Replaces: 02/11.04

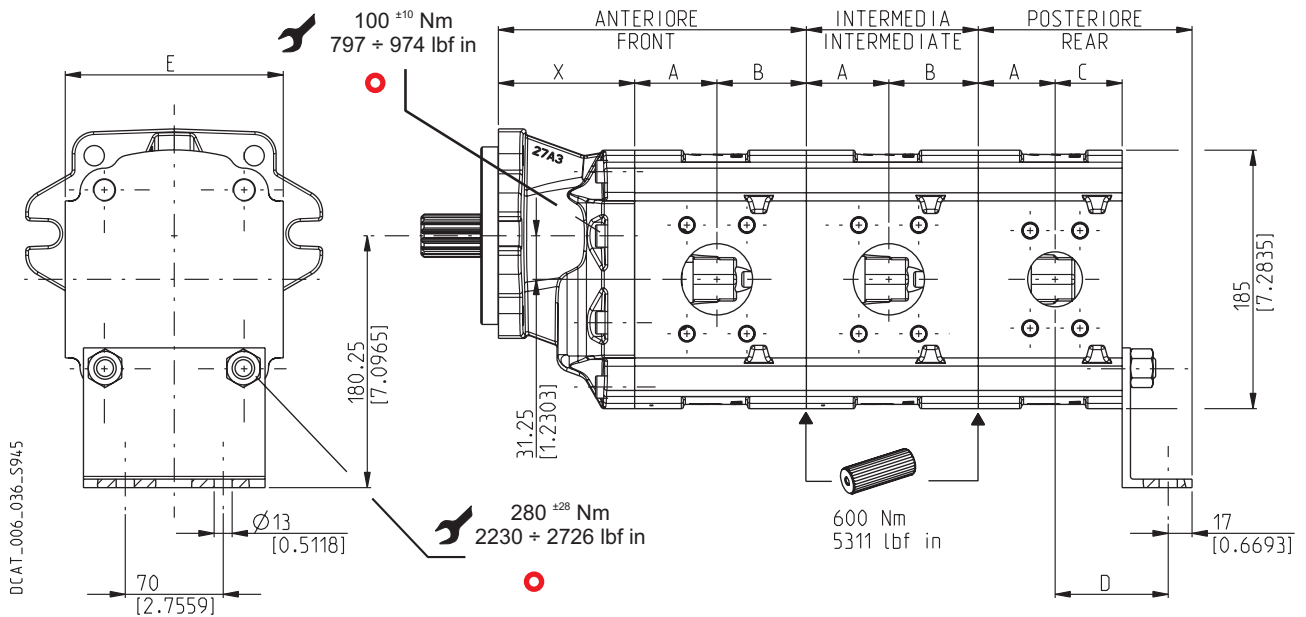

Ports type (see availability on page 47)			
European	Split (SSM) / (SSS)	Gas (BSPP)	SAE (ODT)

DRIVE SHAFTS:
see page 40

MOUNTING FLANGE:
for X dimension see page 46

FRONT: **CSL** (long body)
 INTERMEDIATE: **CSL** (long body)
 REAR: **CSC** (short body)
 (all multiple pumps with more than two sections are available with bracket).

Pump type	A	B	C	D	E		
					European ports Split ports (SSM/SSS)		Gas ports (BSPP) SAE ports (ODT)
					mm (inch)	mm (inch)	mm (inch)
KP 40•63	55 (2.1653)	64 (2.5197)	48 (1.8897)	81 (3.1890)	156 (6.1417)	164 (6.4567)	
KP 40•73	59 (2.3228)	64 (2.5197)	48 (1.8897)	81 (3.1890)	156 (6.1417)	164 (6.4567)	
KP 40•87	64 (2.5197)	64 (2.5197)	48 (1.8897)	81 (3.1890)	156 (6.1417)	164 (6.4567)	
KP 40•109	63 (2.4803)	73 (2.8740)	57 (2.2440)	90 (3.5433)	156 (6.1417)	164 (6.4567)	
KP 40•121	68 (2.6772)	73 (2.8740)	57 (2.2440)	92 (3.6220)	156 (6.1417)	164 (6.4567)	
KP 40•133	72 (2.8346)	73 (2.8740)	57 (2.2440)	92 (3.6220)	156 (6.1417)	164 (6.4567)	

03/07.05

DCAT_006_044_40_30

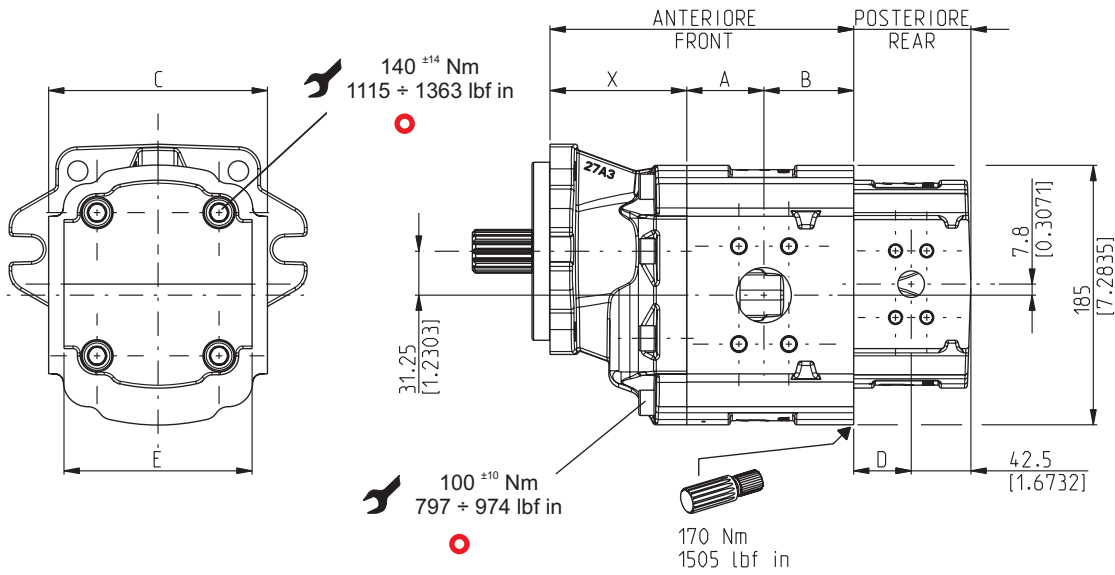

Replaces: 01/05.02

Ports type (see availability on page 47)			
European	Split (SSM) / (SSS)	Gas (BSPP)	SAE (ODT)

DRIVE SHAFTS:
see page 40

MOUNTING FLANGE:
for X dimension see page 46

FRONT: **CSL** (long body)
REAR: KAPPA 30 series **CSC** (short body)

Pump type	A	B	C	
			Eur. ports Split ports	Gas ports SAE ports
	mm (inch)	mm (inch)	mm (inch)	mm (inch)
KP 40-63	55 (2.1653)	64 (2.5197)	156 (6.1417)	164 (6.4567)
KP 40-73	59 (2.3228)	64 (2.5197)	156 (6.1417)	164 (6.4567)
KP 40-87	64 (2.5197)	64 (2.5197)	156 (6.1417)	164 (6.4567)
KP 40-109	63 (2.4803)	73 (2.8740)	156 (6.1417)	164 (6.4567)
KP 40-121	68 (2.6772)	73 (2.8740)	156 (6.1417)	164 (6.4567)
KP 40-133	72 (2.8346)	73 (2.8740)	156 (6.1417)	164 (6.4567)

Pump type	D	E	
		Eur. ports Split portst	Gas ports SAE ports
	mm (inch)	mm (inch)	mm (inch)
KP 30-22	38 (1.4961)	134 (5.2756)	142 (5.5906)
KP 30-27	41 (1.6142)	134 (5.2756)	142 (5.5906)
KP 30-31	43,5 (1.7126)	134 (5.2756)	142 (5.5906)
KP 30-34	46 (1.8110)	134 (5.2756)	142 (5.5906)
KP 30-38	49 (1.9291)	134 (5.2756)	142 (5.5906)
KP 30-41	50,5 (1.9882)	134 (5.2756)	142 (5.5906)
KP 30-43	52 (2.0472)	134 (5.2756)	142 (5.5906)
KP 30-46	53,5 (2.1063)	134 (5.2756)	142 (5.5906)
KP 30-51	57 (2.2441)	134 (5.2756)	142 (5.5906)
KP 30-56	60 (2.3622)	134 (5.2756)	142 (5.5906)
KP 30-61	63 (2.4803)	134 (5.2756)	142 (5.5906)
KP 30-73	71 (2.7953)	134 (5.2756)	142 (5.5906)

03/07.05

Replaces: 02/11.04

DCAT_006_051_PRT02003

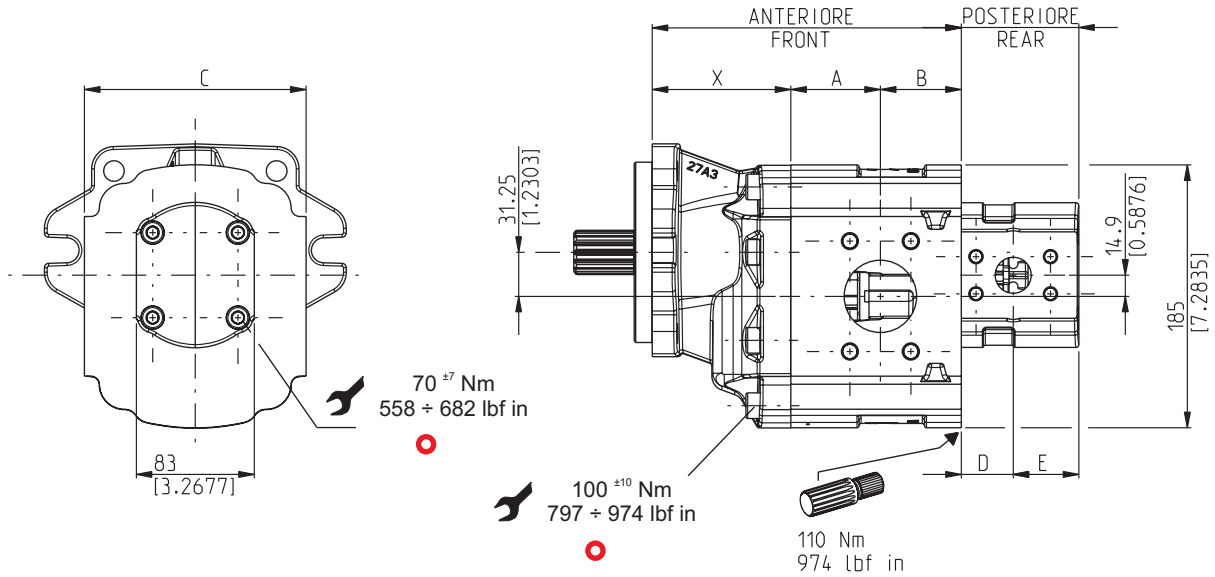

Ports type (see availability on page 47)			
European	Split (SSM) / (SSS)	Gas (BSPP)	SAE (ODT)

DRIVE SHAFTS:
see page 40

MOUNTING FLANGE:
for X dimension see page 46

FRONT: **CSC** (short body)
REAR: Kappa 20 Series (for features please consult the proper technical catalog)

03/07.05

Pump type	A	B	C	
			Eur. ports Split ports	Gas ports SAE ports
	mm (inch)	mm (inch)	mm (inch)	mm (inch)
KP 40•63	55 (2.1653)	48 (1.8897)	156 (6.1417)	164 (6.4567)
KP 40•73	59 (2.3228)	48 (1.8897)	156 (6.1417)	164 (6.4567)
KP 40•87	64 (2.5197)	48 (1.8897)	156 (6.1417)	164 (6.4567)
KP 40•109	63 (2.4803)	57 (2.2440)	156 (6.1417)	164 (6.4567)
KP 40•121	68 (2.6772)	57 (2.2440)	156 (6.1417)	164 (6.4567)
KP 40•133	72 (2.8346)	57 (2.2440)	156 (6.1417)	164 (6.4567)

Pump type	C	D
	mm (inch)	mm (inch)
KP 20•4	24 (0.9449)	39,5 (1.5551)
KP 20•6,3	26,5 (1.0433)	39,5 (1.5551)
KP 20•8	29 (1.1417)	39,5 (1.5551)
KP 20•11,2	32,5 (1.2795)	40,5 (1.5945)
KP 20•14	31 (1.2205)	47 (1.8504)
KP 20•16	36,5 (1.4370)	45 (1.7717)
KP 20•20	43 (1.6929)	45 (1.7717)
KP 20•25	36 (1.4173)	60 (2.3622)
KP 20•31,5	46 (1.8110)	60 (2.3622)

KAPPA 40

DOUBLE PUMPS KP40/PL20 SHORT BODY

CSC

DCAT_006_052_80030242

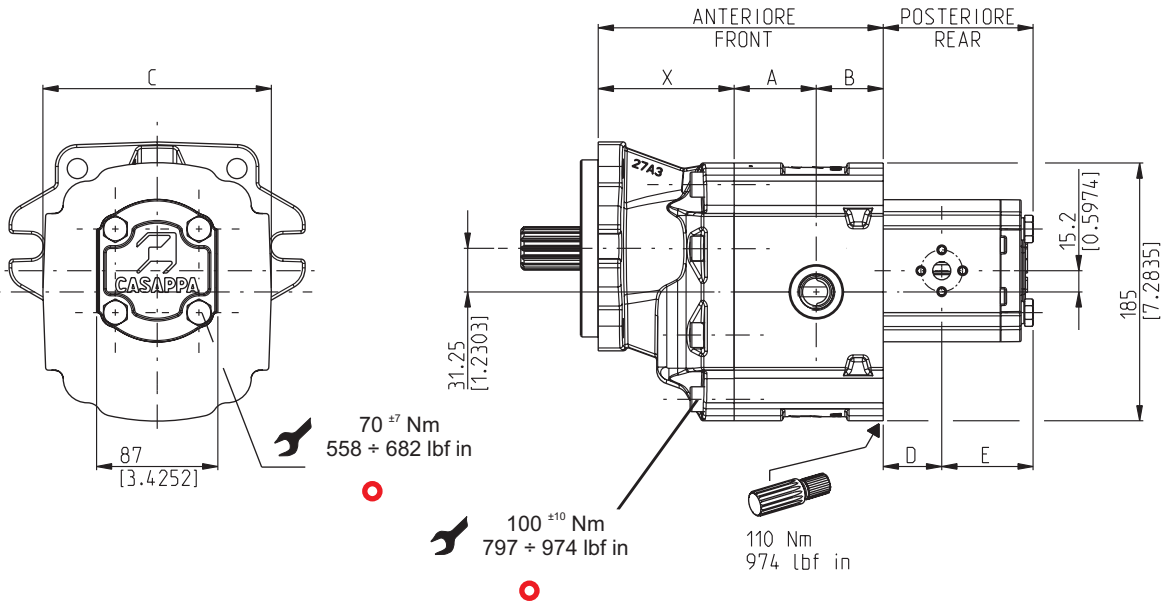

DRIVE SHAFTS:
see page 40

MOUNTING FLANGE:
for X dimension see page 46

FRONT: **CSC** (short body)
REAR: Polaris 20 Series (for features please consult the proper technical catalog)

Ports type (see availability on page 47)			
European	Split (SSM) / (SSS)	Gas (BSPP)	SAE (ODT)

Pump type	B	C
	mm (inch)	mm (inch)
PLP 20•4	25,8 (1.0157)	49,3 (1.9409)
PLP 20•6,3	27 (1.0630)	50,5 (1.9882)
PLP 20•7,2	27,5 (1.0826)	51 (2.0079)
PLP 20•8	28,3 (1.1142)	51,8 (2.0394)
PLP 20•9	28,9 (1.1378)	52,4 (2.0630)
PLP 20•10,5	30,3 (1.1929)	53,8 (2.1181)
PLP 20•11,2	30,5 (1.2008)	54 (2.1260)
PLP 20•14	33 (1.2992)	56,5 (2.2244)
PLP 20•16	34,8 (1.3701)	58,3 (2.2953)
PLP 20•19	36,5 (1.4370)	60 (2.3622)
PLP 20•20	38 (1.4961)	61,5 (2.4213)
PLP 20•24,5	40,8 (1.6063)	64,3 (2.5315)
PLP 20•25	42 (1.6535)	65,5 (2.5787)
PLP 20•27,5	43,4 (1.7087)	66,9 (2.6339)
PLP 20•31,5	47 (1.8504)	70,5 (2.7756)

Pump type	A	B	C	
			Eur. ports Split ports	Gas ports SAE ports
	mm (inch)	mm (inch)	mm (inch)	mm (inch)
KP 40•63	55 (2.1653)	48 (1.8897)	156 (6.1417)	164 (6.4567)
KP 40•73	59 (2.3228)	48 (1.8897)	156 (6.1417)	164 (6.4567)
KP 40•87	64 (2.5197)	48 (1.8897)	156 (6.1417)	164 (6.4567)
KP 40•109	63 (2.4803)	57 (2.2440)	156 (6.1417)	164 (6.4567)
KP 40•121	68 (2.6772)	57 (2.2440)	156 (6.1417)	164 (6.4567)
KP 40•133	72 (2.8346)	57 (2.2440)	156 (6.1417)	164 (6.4567)

Replaces: 02/11.04

03/07.05

VERSIONS

For each version, the possible combination between drive shafts and mounting flanges are shown on pages 41 ÷ 46.

Replaces: 01/05.02

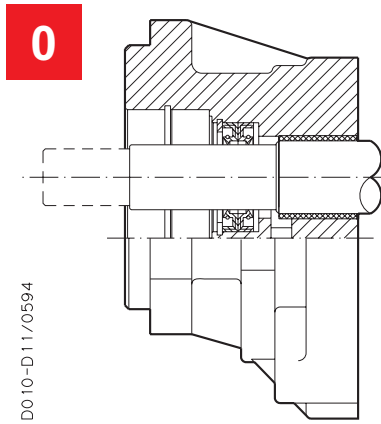

D0 10-D11/0594

Version for applications without radial and axial load on the drive shaft.

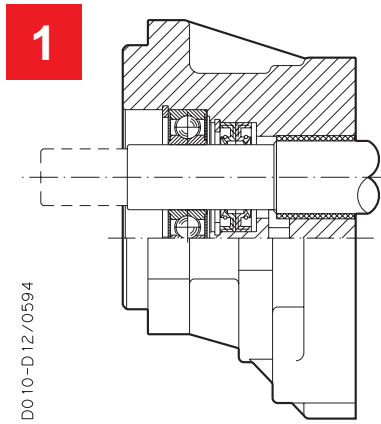

D0 10-D12/0594

Version for applications with low radial load and without axial load on the drive shaft.

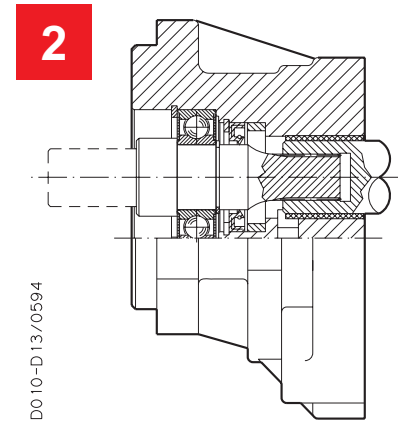

D0 10-D13/0594

Special version with independent shaft for applications with low radial load and without axial load on the drive shaft.

Max. torque version 2:
KAPPA 30: 170 Nm (1505 lbf in)
KAPPA 40: 600 Nm (5311 lbf in)

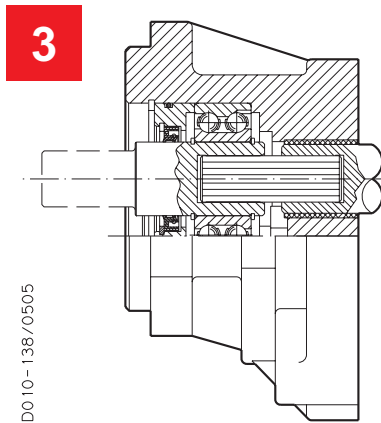

D0 10-138/0505

Version for applications with radial and axial load on the drive shaft.

Max. torque version 3:
KAPPA 30: 170 Nm (1505 lbf in)

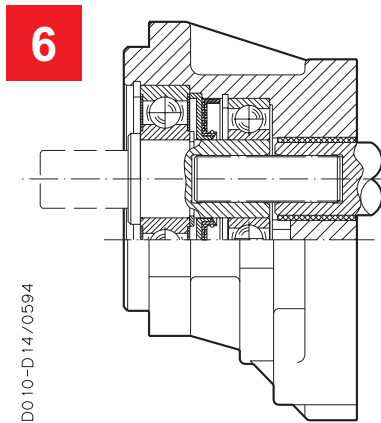

D0 10-D14/0594

Version for applications with radial and axial load on the drive shaft.

Max. torque version 6:
KAPPA 30: 170 Nm (1505 lbf in)
KAPPA 40: 600 Nm (5311 lbf in)

03/07.05

For the outboard bearings life expectancy, diagrams providing approximate selection data will be found on subsequent pages. For particular applications please consult our technical sales department.

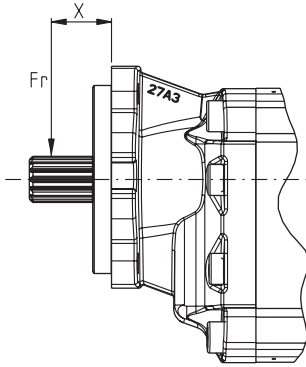

X= Distance of the radial load result from the mounting flange [mm (in)].

Each curve has been obtained at:
 Lubricant oil ISO VG 46
 Temperature 140 °F (60 °C)
 Without or with very low axial load

Example

Fr Radial load	1000 N (225.0 lbf)
X	30 mm (1.1811 in)
Speed	2000 min ⁻¹
Rating fatigue life	≈ 1915 h

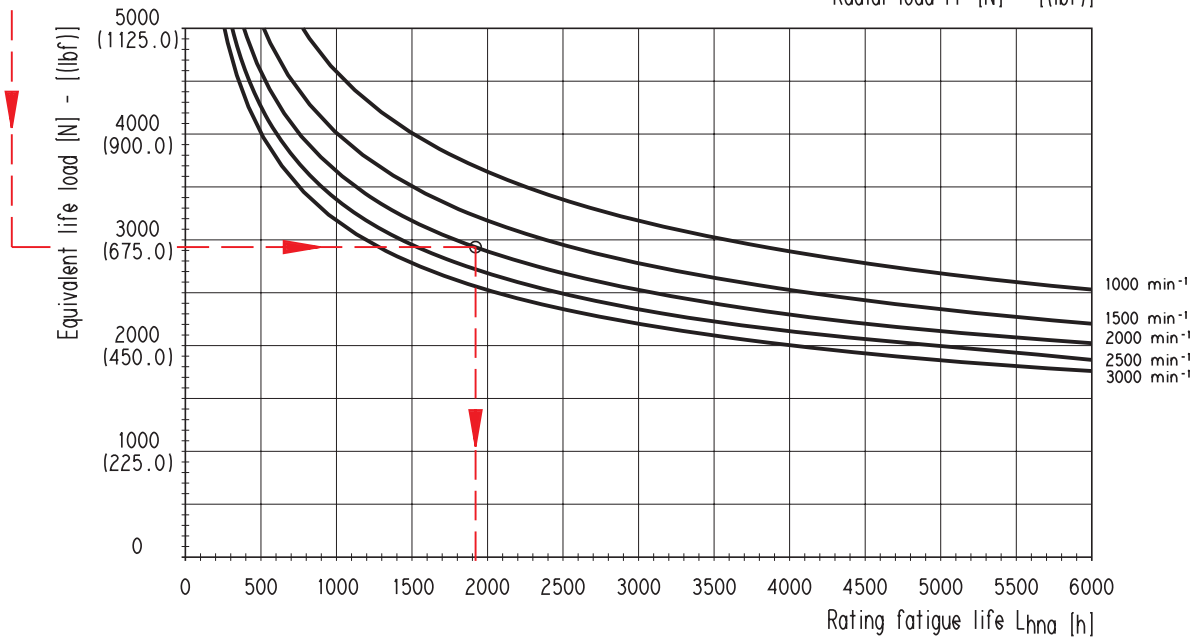
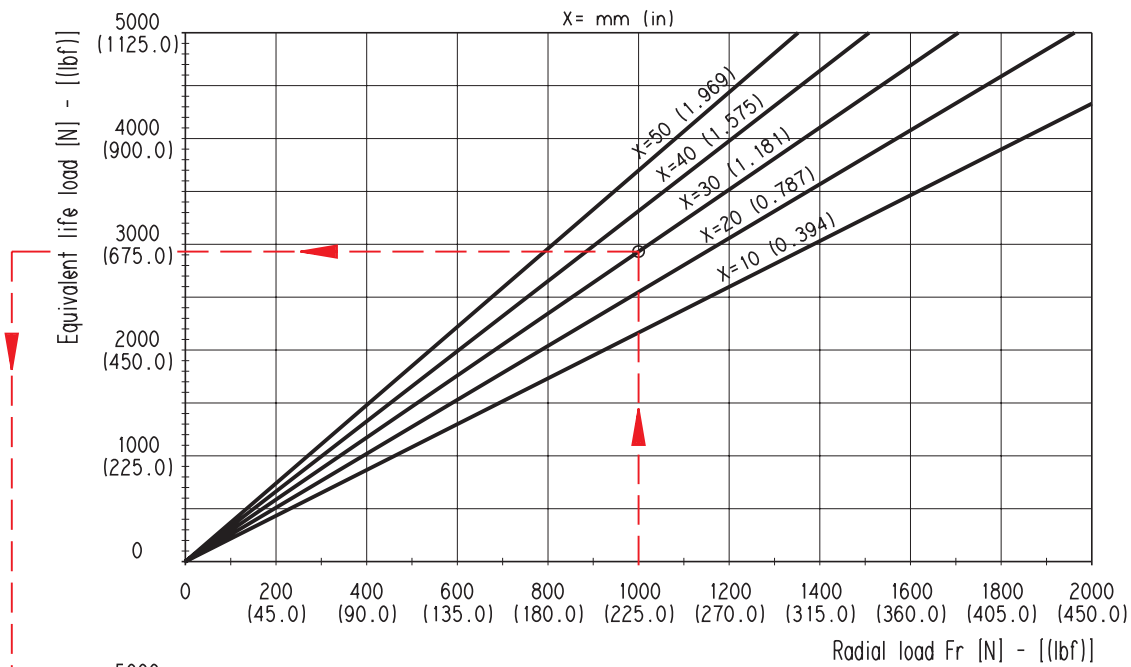

D010-147/0605

03/07.05

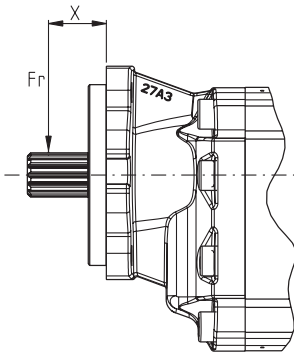

X= Distance of the radial load result from the mounting flange [mm (in)].

Each curve has been obtained at:
 Lubricant oil ISO VG 46
 Temperature 140 °F (60 °C)
 Without or with very low axial load

Example

Fr Radial load	1500 N (337.5 lbf)
X	30 mm (1.1811 in)
Speed	2000 min ⁻¹
Rating fatigue life	≈ 2613 h

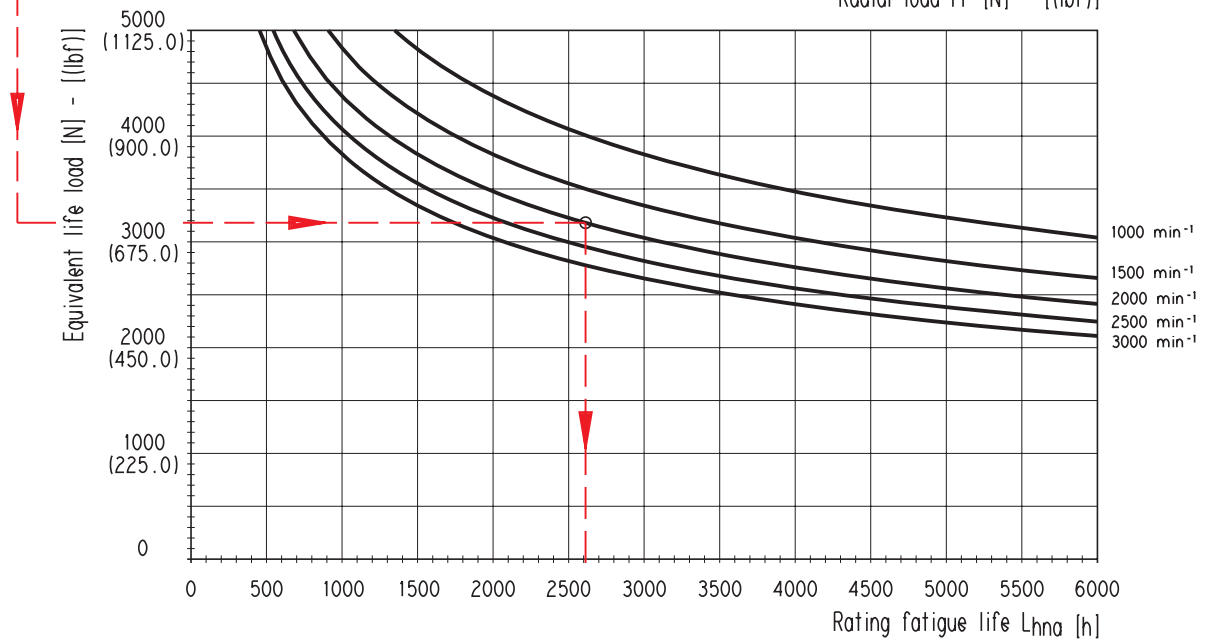
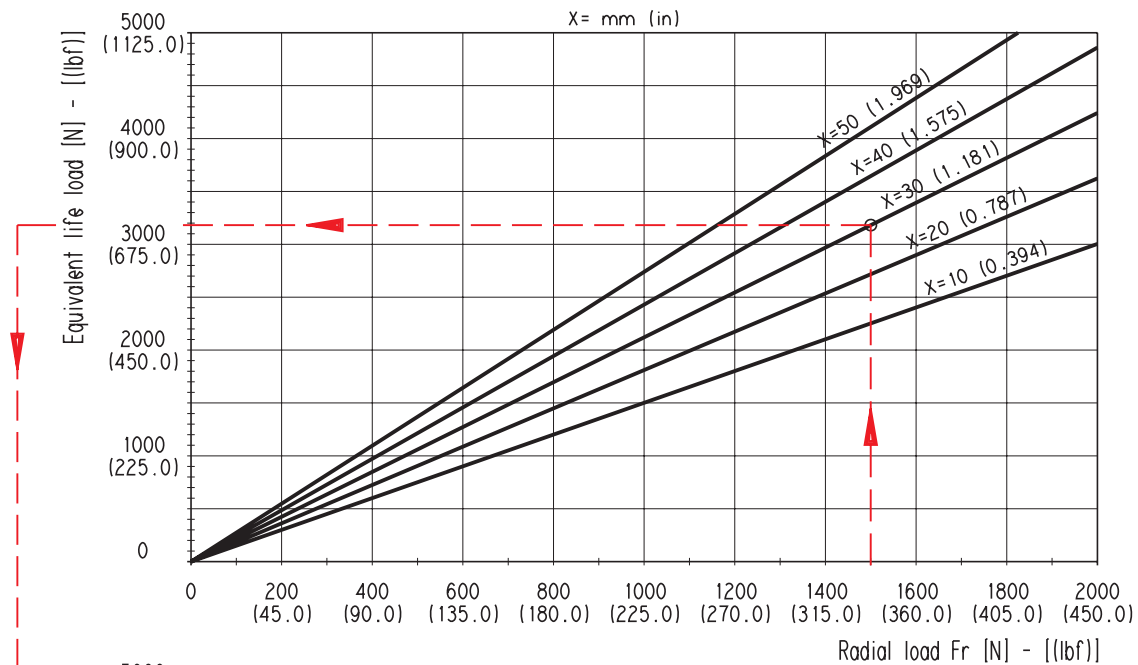

03/07.05

D010-149/0605

KAPPA 30

DRIVE SHAFTS

SAE "B" SPLINE

A8

Mounting face refer to flange code **K9**

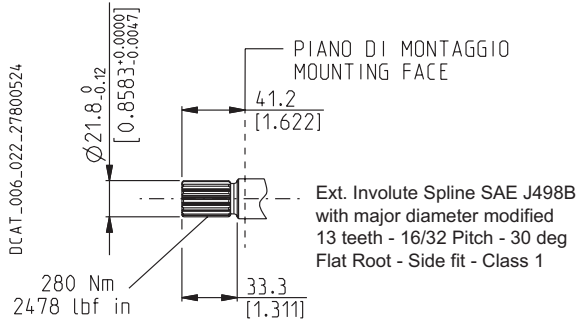

SAE "BB" SPLINE

A5

Not available with size:

30•31	30•41	30•46		
--------------	--------------	--------------	--	--

Mounting face refer to flange code **K9**

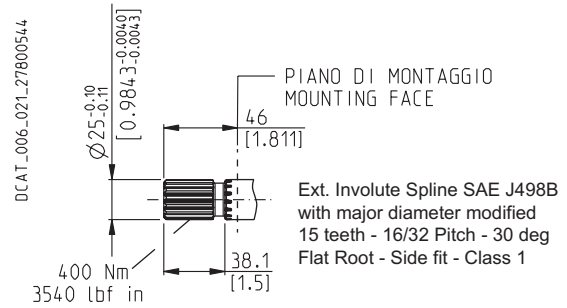

SAE "B" SPLINE

04

Not available with size:

30•41	30•46			
--------------	--------------	--	--	--

Mounting face refer to flange code **S3**

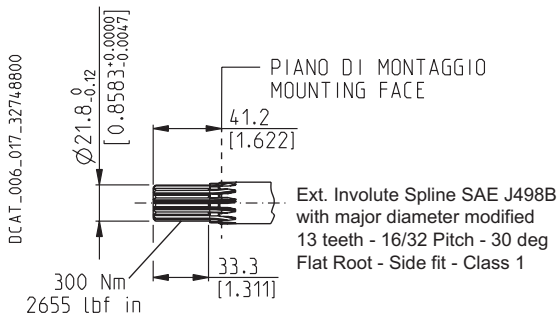

SAE "B" STRAIGHT

32

Not available with size:

30•31	30•41	30•46		
--------------	--------------	--------------	--	--

Mounting face refer to flange code **S3**

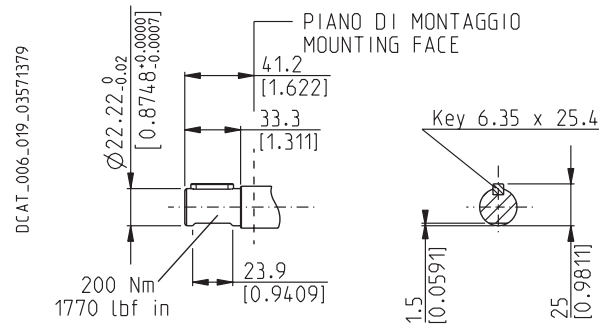

SAE "BB" SPLINE

05

Not available with size:

30•22	30•31	30•41	30•46	
--------------	--------------	--------------	--------------	--

Mounting face refer to flange code **S3**

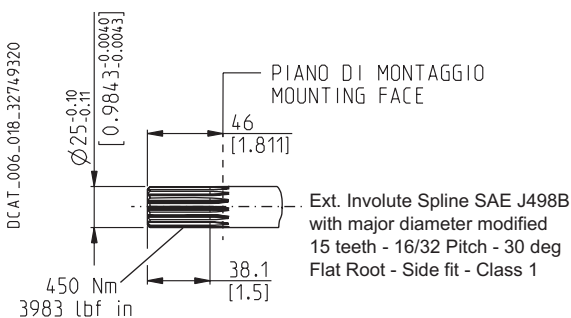

SAE "BB" STRAIGHT

33

Not available with size:

30•22	30•31	30•41	30•46	30•56
--------------	--------------	--------------	--------------	--------------

Mounting face refer to flange code **S3**

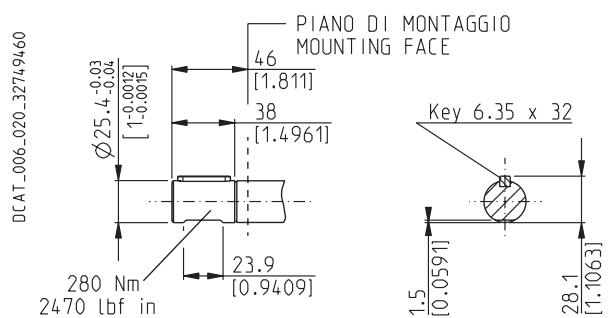

KAPPA 30

DRIVE SHAFTS

SAE "C" SPLINE

06

Not available with size:

30•22	30•31	30•41	30•46	30•56
--------------	--------------	--------------	--------------	--------------

Mounting face refer to flange code **S8**

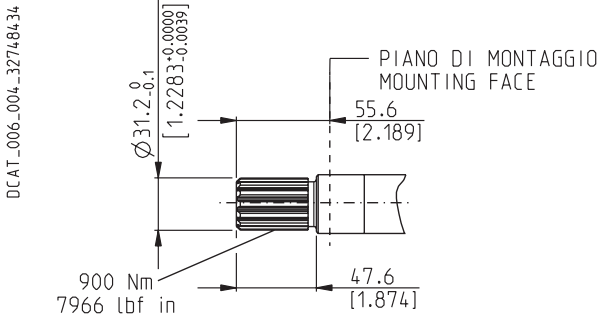

Ext. Involute Spline SAE J498B
with major diameter modified
14 teeth - 12/24 Pitch - 30 deg
Flat Root - Side fit - Class 1

EUROPEAN TAPERED 1:8

83

Not available with size:

30•31	30•41	30•46	30•56	
--------------	--------------	--------------	--------------	--

Mounting face refer to flange code **E3**

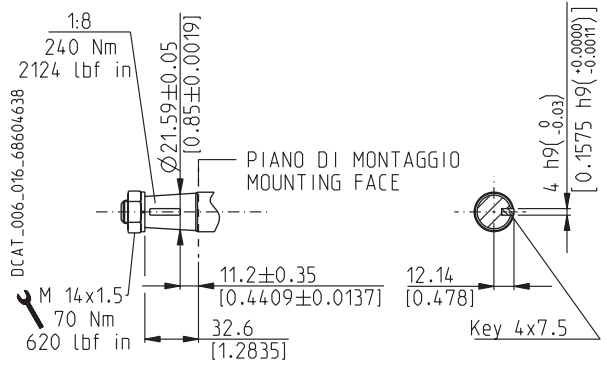

M 14x1.5
70 Nm
620 lbf in

12.14
[0.478]

Key 4x7.5

Replaces: 01/05.02

SAE "C" SPLINE - SHORT TYPE

A6

Available only with size:

30•56	30•73			
--------------	--------------	--	--	--

Mounting face refer to flange code **Q3**

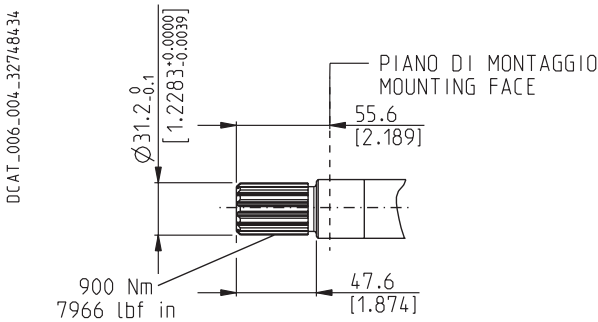

Ext. Involute Spline SAE J498B
with major diameter modified
14 teeth - 12/24 Pitch - 30 deg
Flat Root - Side fit - Class 1

03/07.05

KAPPA 40

DRIVE SHAFTS

SAE "C" SPLINE

06

Not available with size:

40•121				
---------------	--	--	--	--

Mounting face refer to flange code **S8**

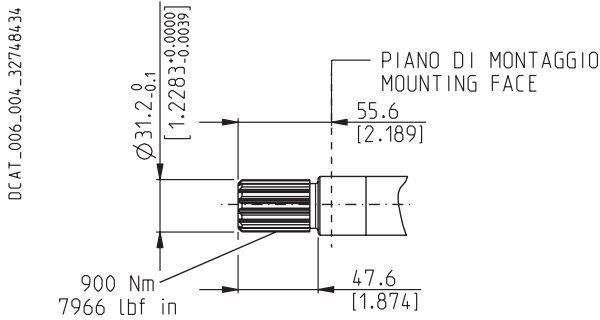

Ext. Involute Spline SAE J498B
with major diameter modified
14 teeth - 12/24 Pitch - 30 deg
Flat Root - Side fit - Class 1

SAE "C" STRAIGHT

34

Not available with size:

40•121				
---------------	--	--	--	--

Mounting face refer to flange code **S8**

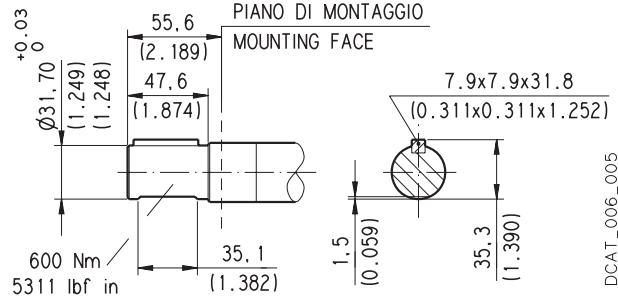

EUROPEAN TAPERED 1:8

85

Not available with size:

40•63	40•151			
--------------	---------------	--	--	--

Mounting face refer to flange code **E5**

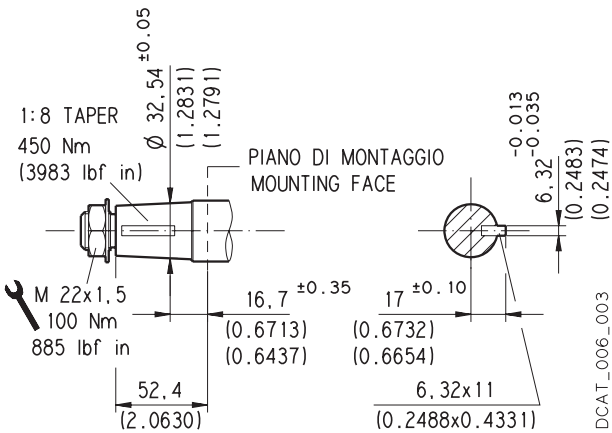

KAPPA 30

MOUNTING FLANGES AND TABLE OF COMPATIBILITY

SAE "B" 2 HOLES

K9

Conforms to SAE J744

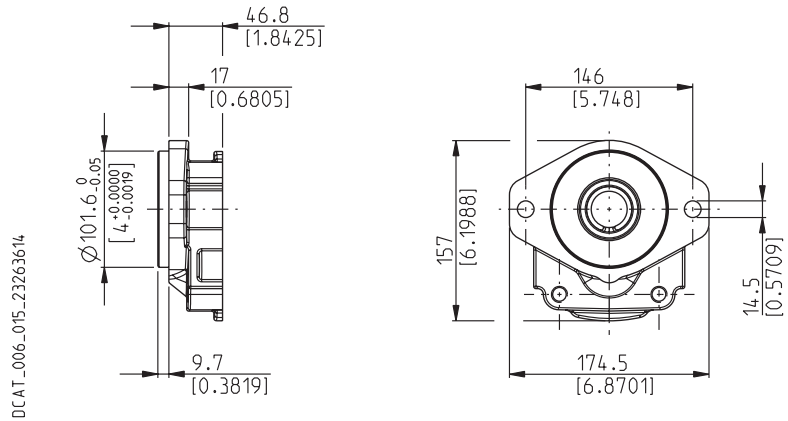

VERSIONS See page 35	DRIVE SHAFTS See page 38	
	A8	A5
0	■	•

- Standard combination
- Available combination

Note: For the mounting with flanged ports bodies, we recommend to use studs.

SAE "A" 2 HOLES

S9

Conforms to SAE J744

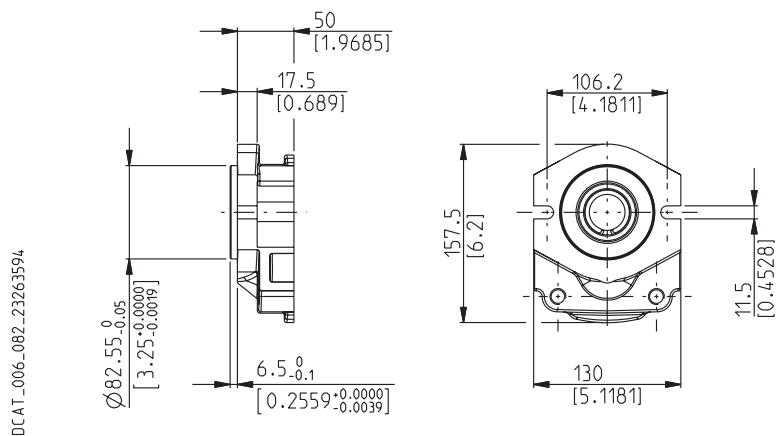

VERSIONS See page 35	DRIVE SHAFTS See page 38	
	A8	
0	■	

- Standard combination
- Available combination

03/07.05

KAPPA 30

MOUNTING FLANGES AND TABLE OF COMPATIBILITY

SAE "A" 2 HOLES

S1

Conforms to SAE J744

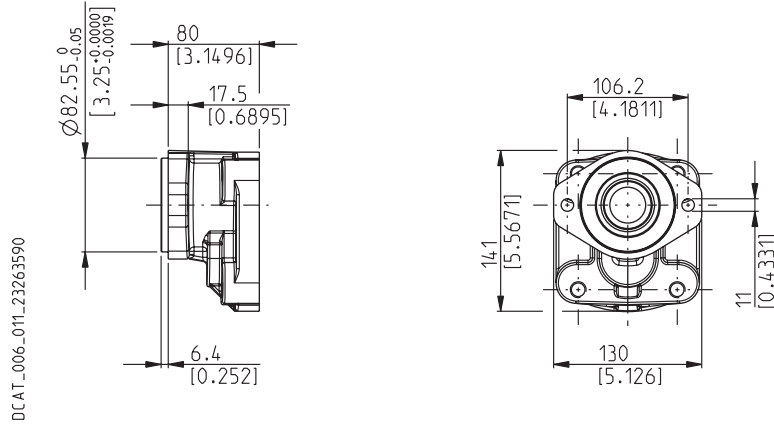

DRIVE SHAFTS
See page 38

VERSIONS See page 35	04	32	05	33
0	■	•	•	•
1	■	•	•	•
2	■	•	•	•

- Standard combination
- Available combination

SAE "A" 2 HOLES

S2

Conforms to SAE J744

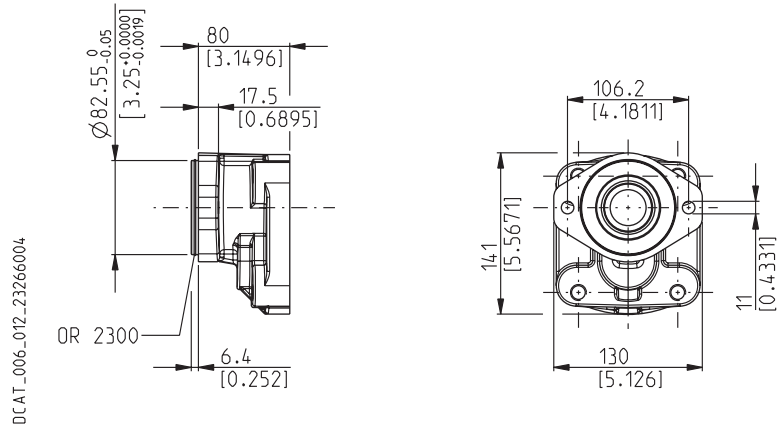

DRIVE SHAFTS
See page 38

VERSIONS See page 35	04	32	05	33
0	■	•	•	•
1	■	•	•	•
2	■	•	•	•

- Standard combination
- Available combination

01/05.02

KAPPA 30

MOUNTING FLANGES AND TABLE OF COMPATIBILITY

SAE "B" 2-4 HOLES

S3

Conforms to SAE J744

DCAT_006_009_23263607

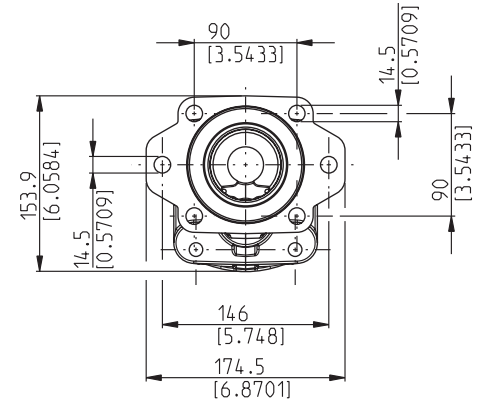
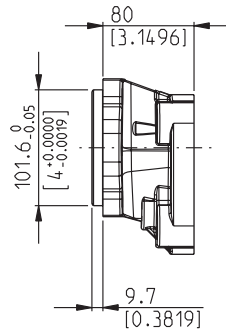

VERSIONS See page 35	DRIVE SHAFTS See page 38			
	04	32	05	33
0	■	•	•	•
1	■	•	•	•
2	■	•	•	•
3	■	•	•	•
6	■	•	•	•

- Standard combination
- Available combination

SAE "C" 4 HOLES

S6

Conforms to SAE J744

DCAT_006_014_23263624

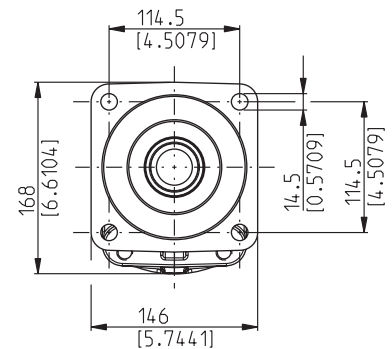
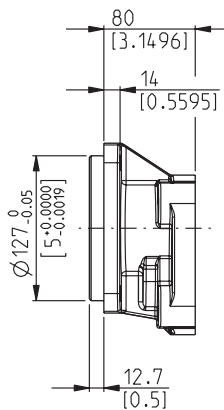

VERSIONS See page 35	DRIVE SHAFTS See page 38 and 39	
	06	05
0	■	•
1	■	•
2	■	•
3	■	•
6	■	•

- Standard combination
- Available combination

01/05.02

KAPPA 30

MOUNTING FLANGES AND TABLE OF COMPATIBILITY

SAE "C" 2 HOLES

S8

Conforms to SAE J744

DCAT_006_053_23263625

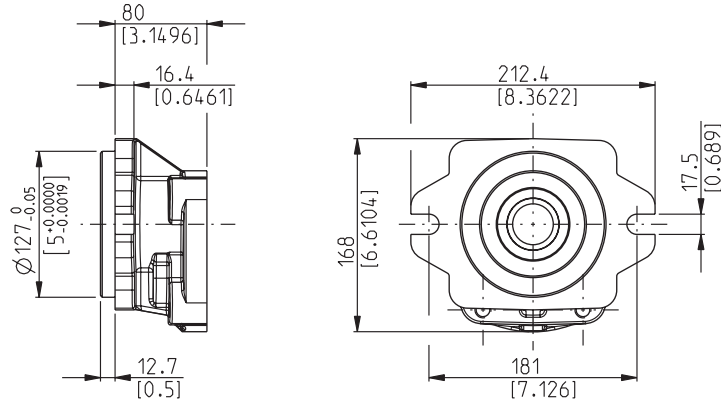

DRIVE SHAFTS
See page 38 and 39

VERSIONS See page 35	06	05
0	■	•
1	■	•
2	■	•
3	■	•
6	■	•

- Standard combination
- Available combination

SAE "C" 2 HOLES

Q3

Conforms to SAE J744

DCAT_006_083_23263633

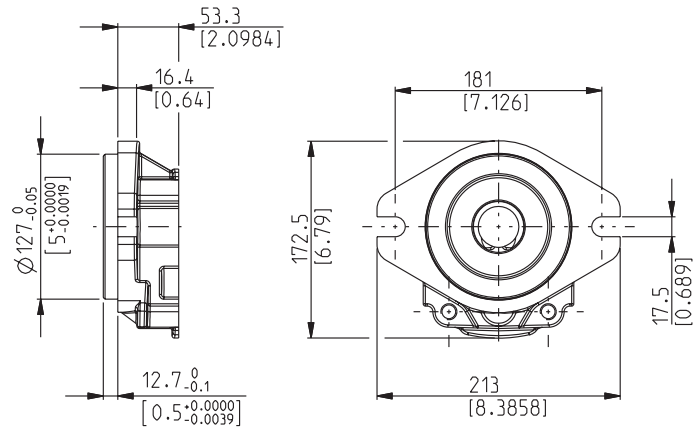

DRIVE SHAFTS
See page 39

VERSIONS See page 35	A6
0	■

- Standard combination
- Available combination

○ 03/07.05

KAPPA 30

MOUNTING FLANGES AND TABLE OF COMPATIBILITY

EUROPEAN
E3

DCAT_006_010_23261018

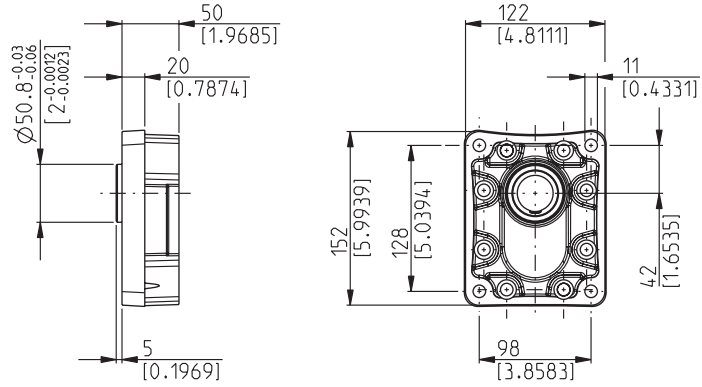

Special version. For more information please consult our technical sales department.

VERSIONS See page 35	DRIVE SHAFTS See page 38 and 39		
	83	A8	A5
0	■	•	•

- Standard combination
- Available combination

01/05.02

KAPPA 40

MOUNTING FLANGES AND TABLE OF COMPATIBILITY

SAE "C" 2-4 HOLES

S8

Conforms to SAE J744

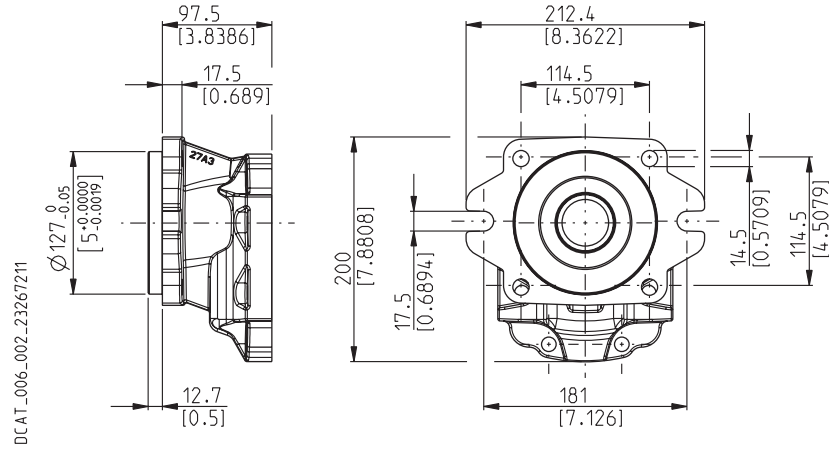

VERSIONS See page 35	DRIVE SHAFTS See page 40	
	06	34
0	■	■
1	■	■
2	■	■

- Standard combination
- Available combination

EUROPEAN

E5

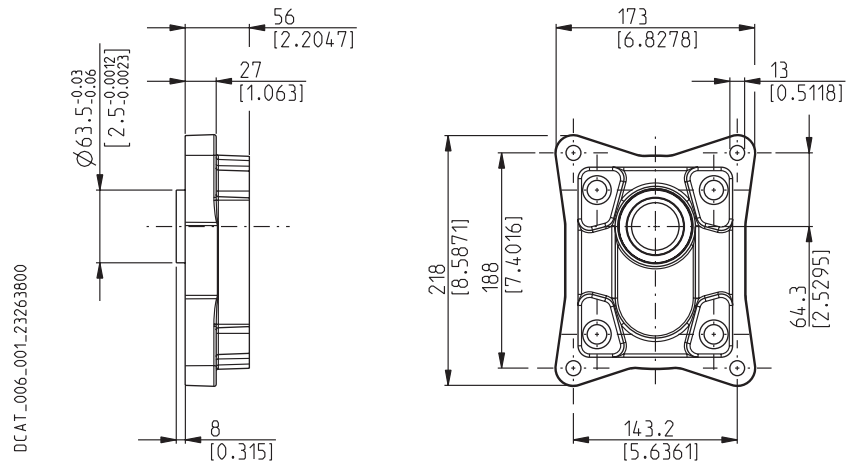

VERSIONS See page 35	DRIVE SHAFTS See page 40	
	85	
0	■	

- Standard combination
- Available combination

01/05.02

PORTS TYPE

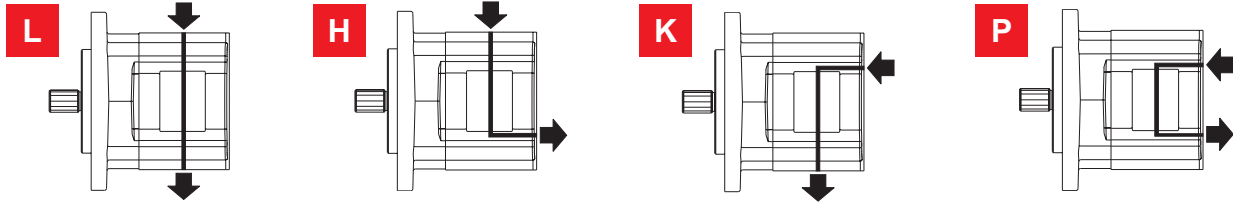

Replaces: 02/11.04

PORTS TYPE	SIDE PORTS										REAR PORTS				
	European		Split SSM		Split SSS		Gas BSPP		SAE ODT		Gas BSPP		SAE ODT		
	Pump type	IN	OUT	IN	OUT	IN	OUT	IN	OUT	IN	OUT	IN	OUT	IN	OUT
Motor type	OUT	IN	OUT	IN	OUT	IN	OUT	IN	OUT	IN	OUT	OUT	IN	OUT	IN
K. 30-22	ED	EB	MC	MB	SC	SB	GF	GE	OF	OD	GF	GE	OF	OD	
K. 30-27	ED	EB	MC	MB	SC	SB	GF	GE	OF	OD	GF	GE	OF	OD	
K. 30-31	ED	EB	MC	MB	SC	SB	GF	GE	OF	OD	GF	GE	OF	OD	
K. 30-34	ED	EB	MC	MB	SC	SB	GF	GE	OF	OD	GF	GE	OF	OD	
K. 30-38	ED	EB	MC	MB	SC	SB	GF	GE	OF	OD	GF	GE	OF	OD	
K. 30-41	ED	EB	MD	MC	SD	SC	GG	GF	OG	OF	GG	GF	OG	OF	
K. 30-43	ED	EB	MD	MC	SD	SC	GG	GF	OG	OF	GG	GF	OG	OF	
K. 30-46	ED	EB	MD	MC	SD	SC	GG	GF	OG	OF	GG	GF	OG	OF	
K. 30-51	ED	EB	MD	MC	SD	SC	GG	GF	OG	OF	GG	GF	OG	OF	
K. 30-56	ED	EB	ME	MD	SE	SD	GG	GF	OG	OF	GG	GF	OG	OF	
K. 30-61	ED	EB	ME	MD	SE	SD	GG	GF	OG	OF	GG	GF	OG	OF	
K. 30-73	EF	ED	ME	MD	SE	SD	GG	GF	OG	OF	GG	GF	OG	OF	
K. 40-63	EG	ED	ME	MD	SE	SD	GG	GF	OG	OF	GF	GE	OF	OD	
K. 40-73	EG	ED	ME	MD	SE	SD	GG	GF	OG	OF	GF	GE	OF	OD	
K. 40-87	EG	ED	MF	ME	SF	SE	GG	GF	OG	OF	GG	GF	OG	OF	
K. 40-109	EG	ED	MF	ME	SF	SE	GG	GF	OG	OF	GG	GF	OG	OF	
K. 40-121	EG	EF	MF	ME	SF	SE	GH	GF	OH	OF	GH	GF	OH	OF	
K. 40-133	EG	EF	MF	ME	SF	SE	GH	GF	OH	OF	GH	GF	OH	OF	
K. 40-151	EG	EF	MF	ME	SF	SE	GH	GF	OH	OF	GH	GF	OH	OF	

EXTERNAL DRAIN PORTS

03/07.05

	GAS BSPP		SAE ODT	
	A	B	A	B
Pump type	A	mm	A	mm
Motor type		(inch)		(inch)
K. 30	GC	23,45 (0.9232)	OA	23,45 (0.9232)
K. 40	GC	31 (1.2205)	OA	31 (1.2205)

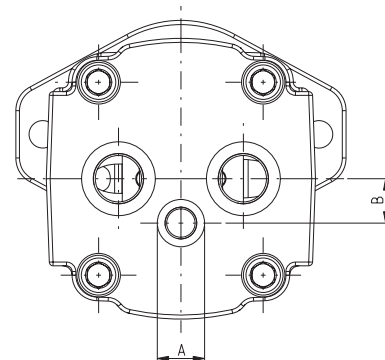

DCAT_006_029_21064838

PORTS SIZES



Tightening torque for low pressure side port



Tightening torque for high pressure side port [values obtained at 5075 psi (350 bar)]

For reversible rotation, please consult only the tightening torque for high pressure side port

EUROPEAN FLANGED PORTS - 4 Bolts

EUROPEAN

Metric thread ISO 60° conforms to ISO/R 262

CODE	A	B	C		
	mm (in)	mm (in)	Thread Depth mm (in)	Nm (lbf in)	Nm (lbf in)
EB	19 (0.7480)	40 (1.5748)	M 8 18 (0.7087)	15 ⁺¹ (133 ÷ 142)	15 ⁺¹ (133 ÷ 142)
ED	27 (1.0630)	51 (2.0079)	M 10 15 (0.5906)	20 ⁺¹ (177 ÷ 186)	30 ^{+2,5} (266 ÷ 288)
			M 10 (◆) 13 (0.5118)		25 ⁺¹ (◆) (221 ÷ 230)
EF	33 (1.2992)	62 (2.4409)	M 12 17 (0.6693)	25 ⁺¹ (221 ÷ 230)	50 ^{+2,5} (443 ÷ 465)
			M 12 (◆) 18 (0.7087)		
EG	38 (1.4961)	72 (2.8346)	M 12 (◆) 18 (0.7087)	30 ^{+2,5} (◆) (266 ÷ 288)	—

DCAT_006_024_21060533

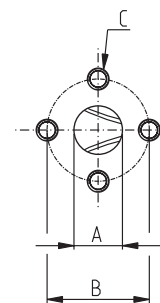

(◆) For KAPPA 40

SAE FLANGED PORTS J518 - Standard pressure series 3000 PSI

SSM

Metric thread ISO 60° conforms to ISO/R 262

CODE	A	B	C	D		
	mm (in)	mm (in)	mm (in)	Thread Depth mm (in)	Nm (lbf in)	Nm (lbf in)
MB	19 (0.7480)	47,6 (1.8740)	22,2 (0.8740)	M 10 17 (0.6693)	20 ⁺¹ (177 ÷ 186)	30 ^{+2,5} (266 ÷ 288)
MC	25,4 (1.0000)	52,4 (2.0630)	26,2 (1.0315)	M 10 17 (0.6693)	20 ⁺¹ (177 ÷ 186)	30 ^{+2,5} (266 ÷ 288)
MD	30,5 (1.2008)	58,7 (2.3110)	30,2 (1.1890)	M 10 17 (0.6693)	20 ⁺¹ (177 ÷ 186)	35 ^{+2,5} (310 ÷ 332)
				M 10 (◆) 22 (0.8661)		
ME	39,3 (1.5472)	69,8 (2.7480)	35,7 (1.4055)	M 12 17 (0.6693)	30 ^{+2,5} (266 ÷ 288)	60 ⁺⁵ (531 ÷ 575)
				M 12 (◆) 27 (1.0630)		
MF	51 (2.0079)	77,8 (3.0630)	42,9 (1.6890)	M 12 (◆) 27 (1.0630)	25 ⁺¹ (◆) (221 ÷ 230)	—

DCAT_006_025_21064252

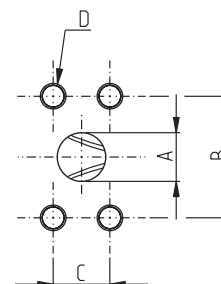

(◆) For KAPPA 40

02/11.04

PORTS SIZES



Tightening torque for low pressure side port



Tightening torque for high pressure side port [values obtained at 5075 psi (350 bar)]

For reversible rotation, please consult only the tightening torque for high pressure side port

SAE FLANGED PORTS J518 - Standard pressure series 3000 PSI

SSS

American straight thread UNC-UNF 60° conforms to ANSI B 1.1

CODE	A	B	C	D		
	mm (in)	mm (in)	mm (in)	Thread Depth mm (in)	Nm (lbf in)	Nm (lbf in)
SB	19 (0.7480)	47,6 (1.8740)	22,2 (0.8740)	3/8 - 16 UNC-2B 17 (0.6693)	20 ⁺¹ (177 ÷ 186)	25 ⁺¹ (221 ÷ 230)
SC	25,4 (1.0000)	52,4 (2.0630)	26,2 (1.0315)	3/8 - 16 UNC-2B 17 (0.6693)	20 ⁺¹ (177 ÷ 186)	30 ^{+2,5} (266 ÷ 288)
SD	30,5 (1.2008)	58,7 (2.3110)	30,2 (1.1890)	7/16 - 14 UNC-2B 17 (0.6693)	20 ⁺¹ (177 ÷ 186)	45 ^{+2,5} (398 ÷ 420)
				7/16 - 14 UNC-2B 28 (1.1024) (◆)		
SE	39,3 (1.5472)	69,8 (2.7480)	35,7 (1.4055)	1/2 - 13 UNC-2B 17 (0.6693)	30 ^{+2,5} (266 ÷ 288)	70 ⁺⁵ (620 ÷ 664)
				1/2 - 13 UNC-2B 27 (1.0630) (◆)		
SF	51 (2.0079)	77,8 (3.0630)	42,9 (1.6890)	1/2 - 13 UNC-2B 27 (1.0630) (◆)	30 ^{+2,5} (◆) (266 ÷ 288)	—

DCAT_006_028_21060740

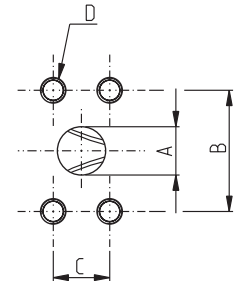

(◆) For KAPPA 40

GAS STRAIGHT THREAD PORTS

BSPP

British standard pipe parallel (55°) conforms to UNI - ISO 228

DCAT_006_026_21064779

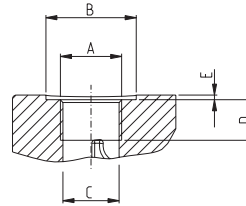

CODE	Nominal size	A	Ø B	Ø C	D	E		
			mm (in)	mm (in)	mm (in)	mm (in)	Nm (lbf in)	Nm (lbf in)
GC (◆)	3/8"	G 3/8	25 (0.9843)	15 (0.5906)	14 (0.5512)	2 (0.0787)	15 ⁺¹ (133 ÷ 142)	—
GE	3/4"	G 3/4	39 (1.5354)	24,5 (0.9646)	18 (0.7087)	2,5 (0.0984)	30 ^{+2,5} (266 ÷ 288)	90 ⁺⁵ (797 ÷ 841)
GF	1"	G 1	49 (1.9291)	30,5 (1.2008)	22 (0.8661)	2,5 (0.0984)	50 ^{+2,5} (443 ÷ 465)	130 ⁺¹⁰ (1151 ÷ 1239)
GG	1" 1/4	G 1 1/4	56 (2.2047)	39 (1.5354)	24 (0.9449)	2,5 (0.0984)	60 ⁺⁵ (531 ÷ 575)	170 ⁺¹⁰ (1505 ÷ 1593)
GH	1" 1/2	G 1 1/2	72 (2.8346)	45 (1.7717)	26 (1.0236)	2,5 (0.0984)	70 ⁺⁵ (620 ÷ 664)	—

(◆) = Drain port

02/11.04

PORTS SIZES



Tightening torque for low pressure side port



Tightening torque for high pressure side port [values obtained at 5075 psi (350 bar)]

For reversible rotation, please consult only the tightening torque for high pressure side port

SAE STRAIGHT THREAD PORTS J514

ODT

American straight thread UNC-UNF 60° conforms to ANSI B 1.1

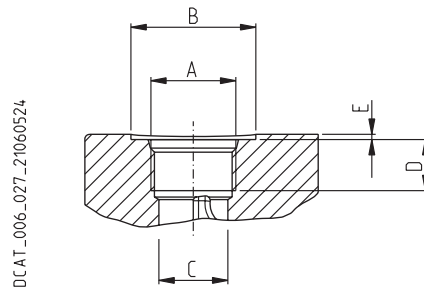

CODE	Nominal size	A	Ø B	Ø C	D	E		
			mm (in)	mm (in)	mm (in)	mm (in)	Nm (lbf in)	Nm (lbf in)
OA (◆)	3/8"	9/16" - 12 UNF - 2B	26 (1.0236)	13 (0.5118)	15 (0.5906)	2 (0.0787)	15 ⁺¹ (133 ÷ 142)	—
OD	3/4"	1 1/16" - 12 UNF - 2B	42 (1.6535)	24,8 (0.9764)	20 (0.7874)	2 (0.0787)	40 ^{+2,5} (354 ÷ 376)	120 ⁺¹⁰ (1062 ÷ 1151)
OF	1"	1 5/16" - 12 UNF - 2B	49 (1.9291)	30,5 (1.2008)	20 (0.7874)	2 (0.0787)	60 ⁺⁵ (531 ÷ 575)	170 ⁺¹⁰ (1505 ÷ 1593)
OG	1" 1/4	1 5/8" - 12 UNF - 2B	58 (2.2835)	39,1 (1.5394)	20 (0.7874)	2 (0.0787)	70 ⁺⁵ (620 ÷ 664)	—
OH	1" 1/2	1 7/8" - 12 UNF - 2B	65 (2.5591)	45 (1.7717)	20 (0.7874)	2 (0.0787)	100 ⁺⁵ (885 ÷ 929)	—

(◆) = Drain port

01/05.02

Unidirectional motors - Anti-clock rotation (S)

Antishock and anti-cavitation valves U1

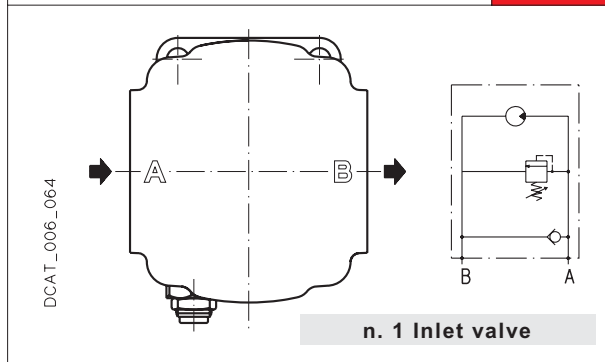

Anti-cavitation valves C1

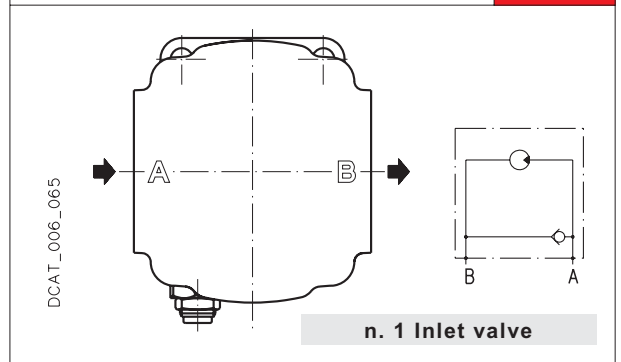

Unidirectional motors - Clockwise rotation (D)

Antishock and anti-cavitation valves U2

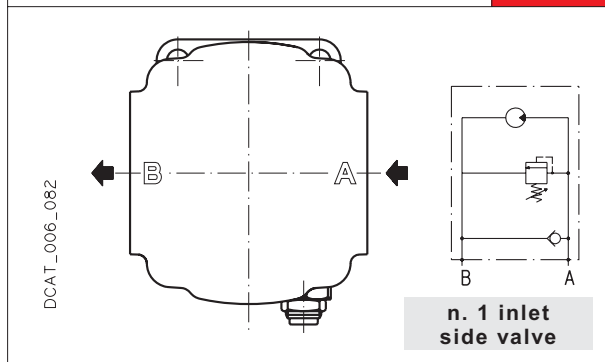

Anti-cavitation valves C2

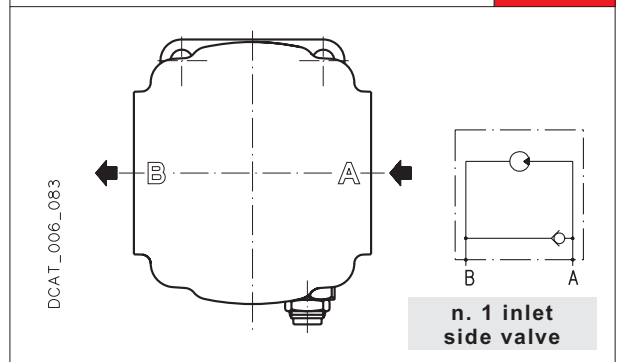

Reversible motors external drain (R)

Antishock and anti-cavitation valves U3

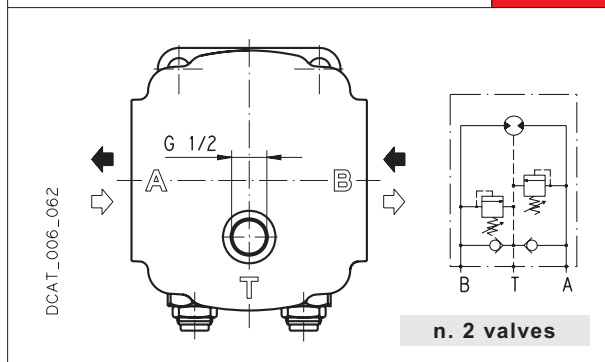

Anti-cavitation valves C3

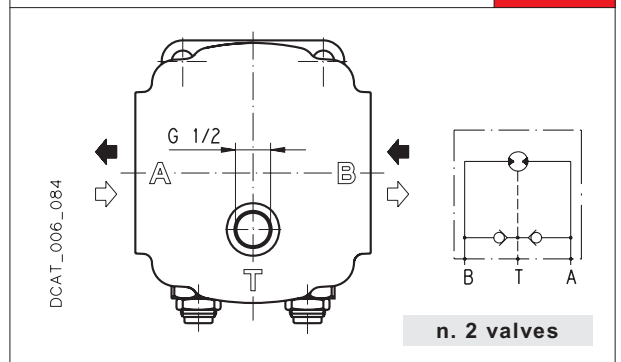

01/05.02

For different valve mounting positions please consult our sales department.

Spring type	Antishock and anti-cavitation valves setting range (U..)
	psi (bar)
G3	725 ÷ 3190 (50 ÷ 220)
G4	2654 ÷ *** (p ₃) (180 ÷ *** [(p ₃)])

*** : G4 spring maximum setting range, see KM30 p₃ peak pressure on page 3

For more information please consult our technical sales department.

HOW TO ORDER



KM30•38 D0-83 E3-L EB/ED-N – U2 (G3 - 200) – CSC

ORDER EXAMPLE

Clockwise motor with antishock and anti-cavitation valve
Setting pressure 2900 psi (200 bar)

KM30•38 D0-83 E3-L EB/ED-N-U2 (G3-200)-CSC

Reversible motor R with anti-cavitation valve

KM30•27 R0-83 E3-L ED/EB-N-C3-CSC

01/05.02

CHANGING ROTATION

Example of changing rotation: from KP30 pump counterclockwise to clockwise

To change rotation of unidirectional pumps and motors is necessary to operate in the following way:

Replaces: 01/05.02

- 1 - Clean the pump externally with care.
- 2 - Loosen, and remove, the clamp bolts (1).
- 3 - Coat the sharp edges of the drive shaft (4) with adhesive tape and smear a layer of clean grease on the shaft end extension to avoid damaging the lip of the shaft seal when removing the mounting flange.
- 4 - Remove the mounting flange (2), taking care to keep the flange as straight as possible during removal. If the flange is stuck, tap around the edge with a fibre or rubber mallet in order to break away

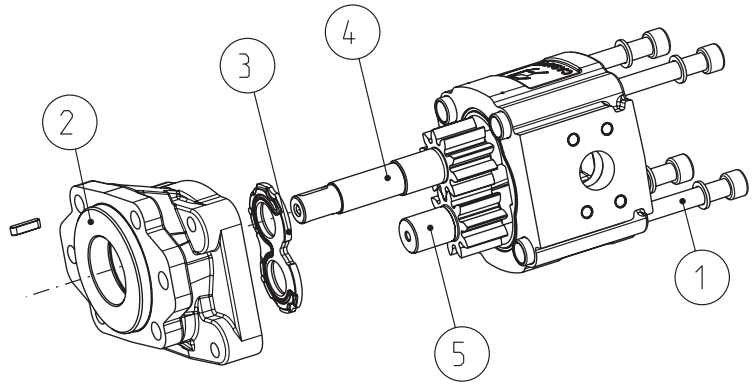

DCAT_006_055_03571379

from the body. Ensure that while removing the front mounting flange, the drive shaft and other components remain position.

- 5 - Ease the drive gear (4) up to facilitate removal the front plate (3), taking care that the precision ground surfaces do not become damaged, and remove the drive gear.
- 6 - Remove the driven gear (5) without overturning. The rear plate has not to be removed

- 7 - Re-locate the driven gear (5) in the position previously occupied by the drive gear (4)
- 8 - Re-locate the drive gear (4) in the position previously occupied by the driven gear (5).
- 9 - Replace the front plate (3) in its original position.

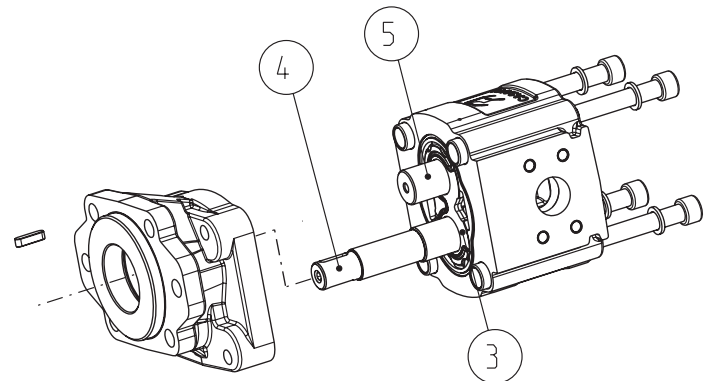

DCAT_006_058_03571379

- 10 - Remove the grub screw (6) from the mounting flange (2) and re-locate it in the other threaded hole in the same flange.
- 11 - Gently wipe the machined surface of the mounting flange (2) and the body with a flat hand stone.
- 12 - Refit the front mounting flange (2) turned 180° from its original position.
- 13 - Refit the clamp bolts (1) with the washers and tighten in a crisscross pattern to a torque value of $1115 \div 1363$ lbf in (140 ±14 Nm)

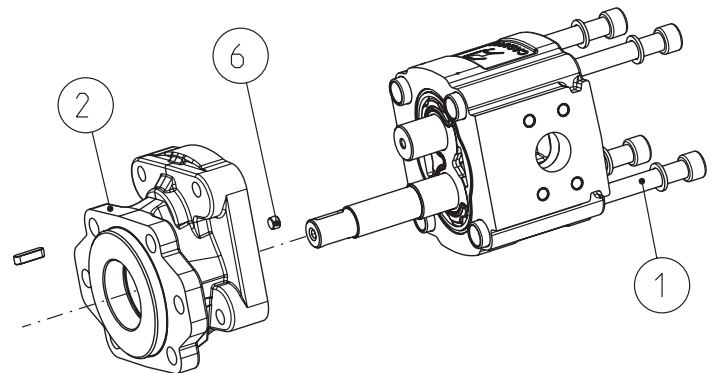

DCAT_006_056_03571379

- 14 - Check that the pump rotates freely when the drive shaft (4) is turned by hand. If not a pressure plate seal may be pinched.
- 15 - The pump is ready for installation with the original rotation reversed.

03/07.05

INSTRUCTIONS

INSTALLATION

Pump

The direction of rotation of single-rotation pumps must be the same as that of the drive shaft. Check that the coupling flange correctly aligns the transmission shaft and the pump shaft. Flexible couplings should be used (never rigid fittings) which will not generate an axial or radial load on the pump shaft.

Motor

The direction of rotation of single-rotation motors must match circuit connections. Check that the coupling flange correctly aligns the transmission shaft and the motor shaft. Flexible couplings should be used (never rigid fittings) which will not generate an axial or radial load on the motor shaft.

TANK

Tank capacity must be sufficient for the system's operating conditions (~ 3 times the amount of oil in circulation) to avoid overheating of the fluid. A heat exchanger should be installed if necessary. The intake and return lines in the tank must be spaced apart (by inserting a vertical divider) to prevent the return-line oil from being taken up again immediately.

LINES

The lines must have a major diameter which is at least as large as the diameter of pump or motor ports, and must be perfectly sealed. To reduce loss of power, the lines should be as short as possible, reducing the sources of hydraulic resistance (elbow, throttling, gate valves, etc.) to a minimum. A length of flexible tubing is recommended to reduce the transmission of vibrations. All return lines must end below the minimum oil level, to prevent foaming. Before connecting the lines, remove any plugs and make sure that the lines are perfectly clean.

FILTERS



We recommend filtering the entire system flow. Filters on suction and return line must be fitted in according to the contamination class as indicated in the first pages of the catalogue. Casappa recommends to use its own production filters:



HYDRAULIC FLUID

Use hydraulic fluid conforming to viscosity data as specified in the first pages of the catalogue. Avoid using mixtures of different oils which could result in decomposition and reduction of the oil's lubricating power.

STARTING UP

Check that all circuit connections are tight and that the entire system is completely clean. Insert the oil in the tank, using a filter. Bleed the circuit to assist in filling. Set the pressure relief valves to the lowest possible setting. Turn on the system for a few moments at minimum speed, then bleed the circuit again and check the level of oil in the tank. In the difference between pump or motor temperature and fluid temperature exceeds 50 °F (10 °C), rapidly switch the system on and off to heat it up gradually. Then gradually increase the pressure and speed of rotation until the pre-set operating levels as specified in the catalogue are attained.

PERIODICAL CHECKS - MAINTENANCE

Keep the outside surface clean especially in the area of the drive shaft seal. In fact, abrasive powder can accelerate wear on the seal and cause leakage. Replace filters regularly to keep the fluid clean. The oil level must be checked and oil replaced periodically depending on the system's operating conditions.

Replaces: 01/05.02

03/07.05

HOW TO ORDER KAPPA 30 SINGLE PUMPS

1	2	3	4	5	6	7	8	9
Pump type Motor type	Rotation	Version	Drive shaft	Mounting flange	Ports position	Ports IN/OUT	Seals	Body type

KP30-27	S	0	-	04	S3	-	L	OF/OD	-	N	-	CSC
----------------	----------	----------	----------	-----------	-----------	----------	----------	--------------	----------	----------	----------	------------

Replaces: 01/05.02

1	Type	PUMP TYPE	MOTOR TYPE
	in ³ /rev (cm ³ /rev)		
1.34	(21,99)	KP 30-22	KM 30-22
1.63	(26,7)	KP 30-27	KM 30-27
1.87	(30,63)	KP 30-31	KM 30-31
2.11	(34,56)	KP 30-34	KM 30-34
2.40	(39,27)	KP 30-38	KM 30-38
2.54	(41,62)	KP 30-41	KM 30-41
2.68	(43,98)	KP 30-43	KM 30-43
2.83	(46,34)	KP 30-46	KM 30-46
3.16	(51,83)	KP 30-51	KM 30-51
3.45	(56,54)	KP 30-56	KM 30-56
3.74	(61,26)	KP 30-61	KM 30-61
4.50	(73,82)	KP 30-73	KM 30-73

2	Rotation	CODE
	Left	S
	Right	D
	Reversible	R
	Reversible internal drain	B

3	Version	CODE
	Without outboard bearing	0
	With outboard bearing	1
	With outboard bearing and indep. shaft	2
	With outboard bearing	3
	With outboard bearing	6

4	Drive shaft	CODE
	European tapered 1:8	83
	SAE "B" spline (13 teeth)	04
	SAE "B" straight	32
	SAE "BB" spline (15 teeth)	05
	SAE "BB" straight	33
	SAE "B" spline (13 teeth) for K9	A8
	SAE "BB" spline (15 teeth) for K9	A5
	SAE "C" spline (14 teeth)	06
	SAE "C" spline short type (14 teeth)	A6

5	Mounting flange	CODE
	European	E3
	SAE "A" 2 holes	S1
	SAE "A" 2 holes with O-ring	S2
	SAE "A" 2 holes short type	S9
	SAE "B" 2-4 holes	S3
	SAE "B" 2 holes	K9
	SAE "C" 4 holes	S6
	SAE "C" 2 holes	S8
	SAE "C" 2 holes short type	Q3

6	Ports position	CODE
	IN/OUT side	L
	IN side / OUT rear	H
	IN rear / OUT side	K
	IN/OUT rear	P

CODE	Ports IN/OUT	7
EUROPEAN FLANGED PORTS		
Side	Rear	Type
ED/EB	KP30	22-27-31-34-38
EB/ED	KM30	41-43-46-51-56-61
EF/ED	KP30	73
ED/EF	KM30	

SAE FLANGED PORTS (SSM)		
Side	Rear	Type
MC/MB	KP30	22-27-31-34-38
MB/MC	KM30	
MD/MC	KP30	41-43-46-51
MC/MD	KM30	
ME/MD	KP30	56-61-73
MD/ME	KM30	

SAE FLANGED PORTS (SSS)		
Side	Rear	Type
SC/SB	KP30	22-27-31-34-38
SB/SC	KM30	
SD/SC	KP30	41-43-46-51
SC/SD	KM30	
SE/SD	KP30	56-61-73

SAE STRAIGHT THREAD PORTS (ODT)		
Side	Rear	Type
OF/OD	OF/OD	22-27-31-34-38
OD/OF	OD/OF	
OG/OF	OG/OF	41-43-46-51 56-61-73
OF/OG	OF/OG	

GAS STRAIGHT THREAD PORTS (BSPP)		
Side	Rear	Type
GF/GE	GF/GE	22-27-31-34-38
GE/GF	GE/GF	
GG/GF	GG/GF	41-43-46-51 56-61-73
GF/GG	GG/GF	

CODE	Seals (a)	8
N	Buna N (standard)	
N-H	Buna N with high back pressure shaft seals	
V	Viton	
N Bz	Buna N and bronze thrust plate	
V Bz	Viton and bronze thrust plate	

CODE	Body type	9
CSC	Short body	
KSC (b)	Short shaped body	

(a) Choose the seals according to the temperature shown on page 1.

(b) Available only with 22-27-31-34-38 displacements.

03/07.05

HOW TO ORDER KAPPA 30 MULTIPLE PUMPS SAME GROUPS

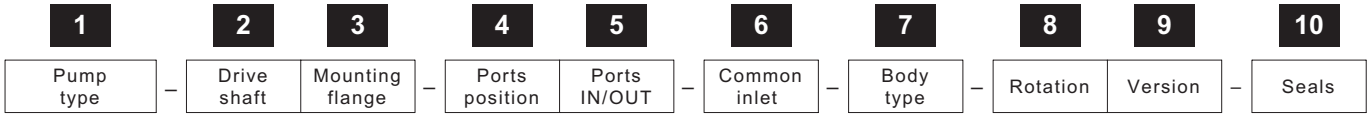

KP 30•51 – A8 K9 – L MD/MC – – CSL /
Front section

30•51 – L MD/MC – – CSL /
Intermediate section

30•51 – L MD/MC – – CSC – S –
Rear section

1	Type	PUMP TYPE
in ³ /rev (cm ³ /rev)		
1.34 (21,99)		KP 30•22
1.63 (26,7)		KP 30•27
1.87 (30,63)		KP 30•31
2.11 (34,56)		KP 30•34
2.40 (39,27)		KP 30•38
2.54 (41,62)		KP 30•41
2.68 (43,98)		KP 30•43
2.83 (46,34)		KP 30•46
3.16 (51,83)		KP 30•51
3.45 (56,54)		KP 30•56
3.74 (61,26)		KP 30•61
4.50 (73,82)		KP 30•73

2	Drive shaft	CODE
	European tapered 1:8	83
	SAE "B" spline (13 teeth)	04
	SAE "B" straight	32
	SAE "BB" spline (15 teeth)	05
	SAE "BB" straight	33
	SAE "B" spline (13 teeth) for K9	A8
	SAE "BB" spline (15 teeth) for K9	A5
	SAE "C" spline (14 teeth)	06
	SAE "C" spline short type (14 teeth)	A6

3	Mounting flange	CODE
	European	E3
	SAE "A" 2 holes	S1
	SAE "A" 2 holes with O-ring	S2
	SAE "A" 2 holes short type	S9
	SAE "B" 2-4 holes	S3
	SAE "B" 2 holes	K9
	SAE "C" 4 holes	S6
	SAE "C" 2 holes	S8
	SAE "C" 2 holes short type	Q3

4	Ports position	CODE
	Side	L

5	Ports IN/OUT	CODE
EUROPEAN FLANGED PORTS		
	Type	Side
	22-27-31-34-38-41-43-46-51-56-61 KP30	ED/EB
	73 KP30	EF/ED

(a) Please write this code only for common inlet pump. (see page 61).
 (b) Available only with 22-27-31-34-38 displacements.

CODE	Ports IN/OUT	5
SAE FLANGED PORTS (SSM)		
Side	Type	
MC/MB	KP30 22-27-34-38	
MD/MC	KP30 43-51	
ME/MD	KP30 56-61-73	
SAE FLANGED PORTS (SSS)		
Side	Type	
SC/SB	KP30 22-27-34-38	
SD/SC	KP30 43-51	
SE/SD	KP30 56-61-73	
SAE STRAIGHT THREAD PORTS (ODT)		
Side	Type	
OF/OD	KP30 22-27-34-38	
OG/OF	KP30 43-51-56-61-73	
GAS STRAIGHT THREAD PORTS (BSPP)		
Side	Type	
GF/GE	KP30 22-27-34-38	
GG/GF	KP30 43-51-56-61-73	

CODE	Body for common inlet (a)	6
M5	Combination KP30/KP30	

CODE	Body type	7
CSL	Long body	
CSC	Short body - Only for rear sections	
KSL	Long shaped body (b)	
KSC	Short shaped body (b) - Only for rear sect.	

CODE	Rotation	8
S	Left	
D	Right	

CODE	Version	9
0	Without outboard bear. (standard) no code	
1	With outboard bearing	
2	With outboard bearing and indep. shaft	
3	With outboard bearing	
6	With outboard bearing	

CODE	Seals (c)	10
N	Buna N (standard) no code	
N-H	Buna N with high back pressure shaft seals	
V	Viton	
N Bz	Buna N and bronze thrust plate	
V Bz	Viton and bronze thrust plate	

(c) Choose the seals according to the temperature shown on page 1. Buna N no code.

Replaces: 01/05.02

03/07.05

HOW TO ORDER KAPPA 30 DOUBLE PUMPS DIFFERENT GROUPS

KP30/KP20

1	2	3	4	5	6	7	8	10	11	12
Pump type	Drive shaft	Mounting flange	Ports position	Ports IN/OUT	Connect. shaft	Common inlet	Body type	Rotation	Version	Seals
KP 30•51	- A8	K9	- L	MD/MC	- 55	-	CSL	/		

Front section

KP20•14	- L MB/MA	- - - S -
---------	-----------	-----------

Rear section

KP30/PLP20

1	2	3	4	5	6	7	8	9	10	11	12
Pump type	Drive shaft	Mount. flange	Ports posit.	Ports IN/OUT	Conn. shaft	Comm. inlet	Body type	Rear cover	Rotation	Version	Seals
KP 30•51	- A8	K9	- L	MD/MC	- 45	-	CSC	/			

Front section

PLP20•14	- L MB/MA	- L S / FS -
----------	-----------	--------------

Rear section

02/11.04

1	Type	PUMP TYPE
	in ³ /rev (cm ³ /rev)	
	The same of multiple pumps on page 56	KP 30•..
2	Drive shaft	CODE
	The same of multiple pumps on page 56	...
3	Mounting flange	CODE
	The same of multiple pumps on page 56	...
4	Ports position	CODE
	Side	L
5	Ports IN/OUT	CODE
	The same of multiple pumps on page 56	../.
6	Connecting shaft	CODE
	Combination KP30/KP20	55
	Combination KP30/PLP20	45
7	Body for common inlet (a)	CODE
	Combination KP30/KP20	N5
	Combination KP30/PLP20	N7

(a) Please write this code only for common inlet pump. (see page 61).

CODE	Body type	8
CSL	Long body (KP30/KP20)	
CSC	Short body (KP30/PLP20)	
HSC	Short shaped body (KP30/PLP20)	

CODE	Rear cover (only PLP20)	9
	Cast iron (standard) no code	
L	Aluminum	
2P	Without cover	

CODE	Rotation	10
S	Left	
D	Right	

CODE	Version	11
...	The same of multiple pumps on page 56	

CODE	Seals	12
	The same of multiple pumps on page 56	

HOW TO ORDER KAPPA 40 SINGLE PUMPS

1	2	3	4	5	6	7	8	9
Pump type Motor type	Rotation	Version	Drive shaft	Mounting flange	Ports position	Ports IN/OUT	Seals	Body type
KP40•63	S	0	– 06	S8	– L	OG/OF	– N	–

1	Type	PUMP TYPE	MOTOR TYPE
	in ³ /rev (cm ³ /rev)		
	3.75 (61,43)	KP 40•63	KM 40•63
	4.43 (72,6)	KP 40•73	KM 40•73
	5.28 (86,56)	KP 40•87	KM 40•87
	6.64 (108,9)	KP 40•109	KM 40•109
	7.43 (121,8)	KP 40•121	KM 40•121
	8.18 (134,03)	KP 40•133	KM 40•133
	9.20 (150,79)	KP 40•151	KM 40•151

2	Rotation	CODE
	Left	S
	Right	D
	Reversible	R
	Reversible internal drain	B

3	Version	CODE
	Without outboard bearing	0
	With outboard bearing	1
	With outboard bearing and indep. shaft	2

4	Drive shaft	CODE
	European tapered 1:8	85
	SAE "C" spline (14 teeth)	06
	SAE "C" straight	34

5	Mounting flange	CODE
	European	E5
	SAE "C" 2-4 holes	S8

6	Ports position	CODE
	Side	L
	Rear	P

CODE	Ports IN/OUT		7
EUROPEAN FLANGED PORTS			
Side	Rear	Type	
EG/ED		KP40	63-73-87-109
ED/EG		KM40	
EG/EF		KP40	121-133-151
EF/EG		KM40	
SAE FLANGED PORTS (SSM)			
Side	Rear	Type	
ME/MD		KP40	63-73
MD/ME		KM40	
MF/ME		KP40	87-109-121-133-151
ME/MF		KM40	
SAE FLANGED PORTS (SSS)			
Side	Rear	Type	
SE/SD		KP40	63-73
SD/SE		KM40	
SF/SE		KP40	87-109-121-133-151
SE/SF		KM40	
SAE STRAIGHT THREAD PORTS (ODT)			
Side	Rear	Type	
OG/OF	OF/OD	KP40	63-73
OF/OG	OD/OF	KM40	
OG/OF	OG/OF	KP40	87-109
OF/OG	OF/OG	KM40	
OH/OF	OH/OF	KP40	121-133-151
OF/OH	OF/OH	KM40	
GAS STRAIGHT THREAD PORTS (BSPP)			
Side	Rear	Type	
GG/GF	GF/GE	KP40	63-73
GF/GG	GE/GF	KM40	
GG/GF	GG/GF	KP40	87-109
GF/GG	GF/GG	KM40	
GH/GF	GH/GF	KP40	121-133-151
GF/GH	GF/GH	KM40	

CODE	Seals (a)	8
N	Buna N (standard)	
N-H	Buna N with high back pressure shaft seals	
V	Viton	
V Bz	Buna N and bronze thrust plate	
V Bz	Viton and bronze thrust plate	

CODE	Body type (b)	9
CSL	Long body	

- (a) Choose the seals according to the temperature shown on page 1
- (b) Please write this code only for pump with rear ports

Replaces: 01/05.022

03/07.05

HOW TO ORDER KAPPA 40 MULTIPLE PUMPS SAME GROUPS

1	2	3	4	5	6	7	8	9	10
Pump type	Drive shaft	Mounting flange	Ports position	Ports IN/OUT	Common inlet	Body type	Rotation	Version	Seals
KP 40•63 – 06 S8 – L OG/OF – – CSL /									
Front section									
40•63 – L OG/OF – – CSL /									
Intermediate section									
40•63 – L OG/OF – – CSC – S –									
Rear section									

1	Type	PUMP TYPE
	in ³ /rev (cm ³ /rev)	
	3.75 (61,43)	KP 40•63
	4.43 (72,6)	KP 40•73
	5.28 (86,56)	KP 40•87
	6.64 (108,9)	KP 40•109
	7.43 (121,8)	KP 40•121
	8.18 (134,03)	KP 40•133
	9.20 (150,79)	KP 40•151
2	Drive shaft	CODE
	European tapered 1:8	85
	SAE "C" spline (14 teeth)	06
	SAE "C" straight	34
3	Mounting flange	CODE
	European	E5
	SAE "C" 2 holes	S8
4	Ports position	CODE
	Side	L
5	Ports IN/OUT	CODE
EUROPEAN FLANGED PORTS		
	Type	Side
	63-73-87-109	KP40
	121-133-151	KP40
		EG/ED
		EG/EF
SAE FLANGED PORTS (SSM)		
	Type	Side
	63-73	KP40
	87-109-121-133-151	KP40
		ME/MD
		MF/ME
SAE FLANGED PORTS (SSS)		
	Type	Side
	63-73	KP40
	87-109-121-133-151	KP40
		SE/SD
		SF/SE

CODE	Ports IN/OUT	5
SAE STRAIGHT THREAD PORTS (ODT)		
Side	Type	
OG/OF	KP40	63-73-87-109
OH/OF	KP40	121-133-151
GAS STRAIGHT THREAD PORTS (BSPP)		
Side	Type	
GG/GF	KP40	63-73-87-109
GH/GF	KP40	121-133-151
CODE	Body for common inlet (a)	6
A5	Combination KP40/KP40	
CODE	Body type (b)	7
CSL	Long body	
CSC	Short body	
CODE	Rotation	8
S	Left	
D	Right	
CODE	Version	9
0	Without outboard bear. (standard) no code	
1	With outboard bearing	
2	With outboard bearing and indep. shaft	
CODE	Seals (c)	10
N	Buna N (standard) no code	
N-H	Buna N with high back pressure shaft seals	
V	Viton	
N Bz	Buna N and bronze thrust plate	
V Bz	Viton and bronze thrust plate	

- (a) Please write this code only for common inlet pump. (see page 61).
- (b) Corpo corto Type CSC solo per sezioni Rear.
- (c) Choose the seals according to the temperature shown on page 1. Buna N no code.

01/05.02

HOW TO ORDER KAPPA 40 DOUBLE PUMPS DIFFERENT GROUPS

KP40/KP30

1	2	3	4	5	6	7	8	10	11	12
Pump type	Drive shaft	Mounting flange	Ports position	Ports IN/OUT	Connect. shaft	Common inlet	Body type	Rotation	Version	Seals
KP 40•63	- 06	S8	- L	ME/MD	- 43	-	CSL	/		

Front section

KP30•51 - L MD/MC - - - CSC S -

Rear section

KP40/KP20

1	2	3	4	5	6	7	8	10	11	12
Pump type	Drive shaft	Mounting flange	Ports position	Ports IN/OUT	Connect. shaft	Common inlet	Body type	Rotation	Version	Seals
KP 40•63	- 06	S8	- L	ME/MD	- 42	-	CSC	/		

Front section

KP20•14 - L MB/MA - - - S -

Rear section

KP40/PLP20

1	2	3	4	5	6	7	8	9	10	11	12
Pump type	Drive shaft	Mount. flange	Ports posit.	Ports IN/OUT	Conn. shaft	Comm. inlet	Body type	Rear cover	Rotation	Version	Seals
KP 40•63	- 06	S8	- L	ME/MD	- 41	-	CSC	/			

Front section

PLP20•14 - L MB/MA - - L S / FS -

Rear section

1	Type	PUMP TYPE
	in ³ /rev (cm ³ /rev)	
	The same of multiple pumps on page 59	KP 40•..
2	Drive shaft	CODE
	The same of multiple pumps on page 59	...
3	Mounting flange	CODE
	The same of multiple pumps on page 59	...
4	Ports position	CODE
	Side	L
5	Ports IN/OUT	CODE
	The same of multiple pumps on page 59	../..
6	Connecting shaft	CODE
	Combination KP40/KP30	43
	Combination KP40/KP20	42
	Combination KP40/PLP20	41

CODE	Body for common inlet (a)	7
C5	Combination KP40/KP30	
D5	Combination KP40/KP20	
D7	Combination KP40/PLP20	
CODE	Body type	8
CSL	Long body (KP30/KP20)	
CSC	Short body (KP30/PLP20)	
CODE	Rear cover (only PLP20)	9
	Cast iron (standard) no code	
L	Aluminum	
2P	Without cover	
CODE	Rotation	10
...	The same of multiple pumps on page 59	
CODE	Version	11
...	The same of multiple pumps on page 59	
CODE	Seals	12
	The same of multiple pumps on page 59	

(a) Please write this code only for common inlet pump (see page 61).

01/05.02

COMMON INLET

Ordering Instructions:

Depending on the required version, the common inlet codes must be used only for the section which has the common suction. For pumps with common inlet for all sections, the code must be used only for the last section. For the sections with only an outlet port, the code of the inlet port must be omitted.

Front pump	Identification code of common inlet body	Rear pump
KP 40	A5	KP 40
KP 40	C5	KP 30
KP 40	D5	KP 20
KP 40	D7	PL 20
KP 30	M5	KP 30
KP 30	N5	KP 20
KP 30	N7	PL 20

Order example

Triple pump Kappa 40+Kappa 30+ Kappa 20.
Common inlet intermediate pump and rear pump.

- KP 40•63-06 S8-L ME/MD-43-CSL** /
Front pump
- KP 30•51-L MD/MC-55-N5-CSL** /
Intermediate pump
- KP 20•14-L /MA-S**
Rear pump

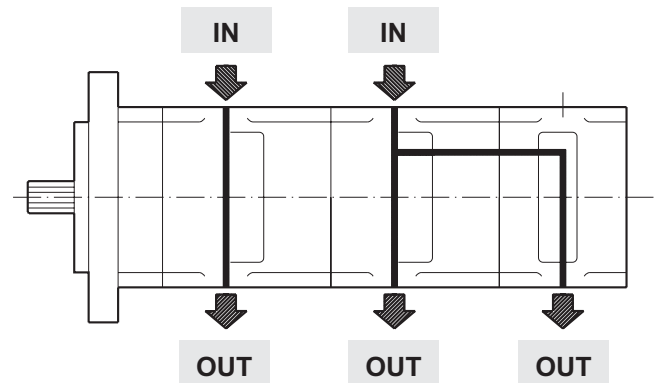

Double pump Kappa 30+Kappa 30.
Common inlet all pumps.

- KP 30•51-A8 K9-L MD/MC-CSL** /
Front pump
- 30•51-L /MC-M5-CSC-S**
Rear pump

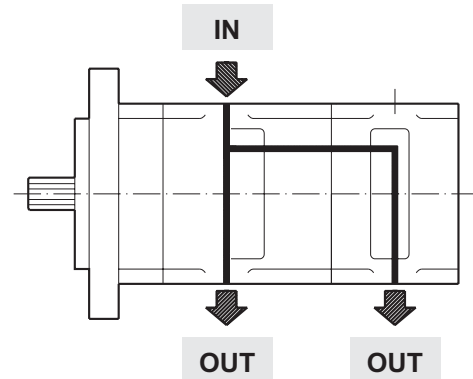

Triple pump Kappa 40+Kappa 40+ Kappa 30
Common inlet all pumps.

- KP 40•63-06 S8-L /MD-CSL** /
Front pump
- 40•63-L ME/MD-43-CSL** /
Intermediate pump
- 30•51-L /MC-C5-CSC-S**
Rear pump

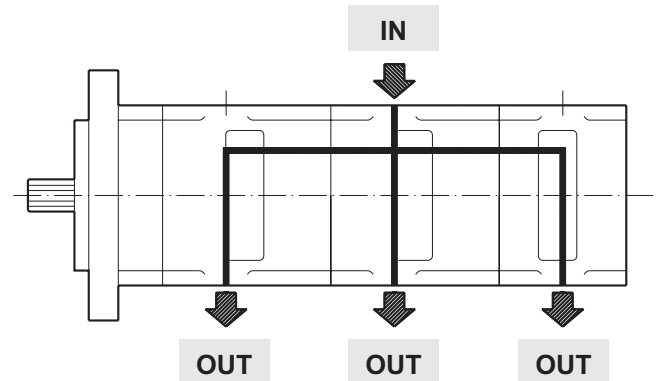

01/05.02

Casappa: Fluid Power Design at 360°

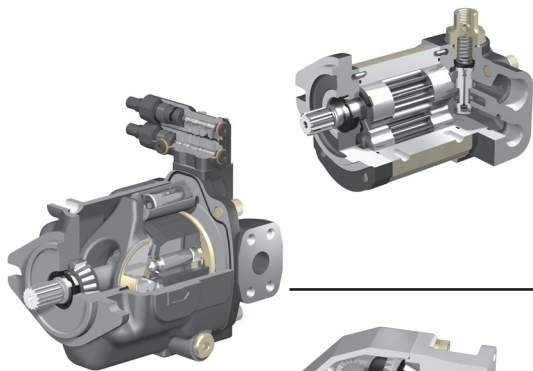

Gear pumps.
High performance, low noise.

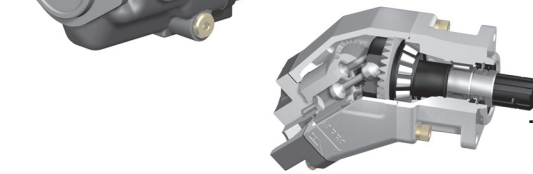

Variable displacement axial piston pumps,
for open circuit.

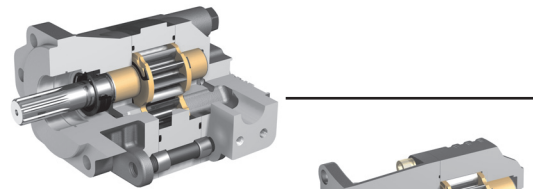

Fixed displacement bent axis piston pumps,
for truck applications.



Cast iron gear pumps and
motors of three part construction.

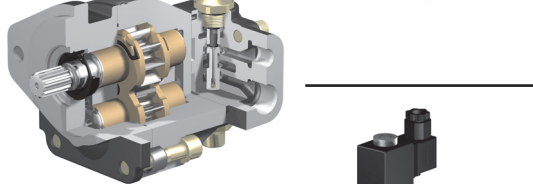

Cast iron gear pumps,
for truck applications.



Cast iron gear pumps and
motors of two part construction.



Gear pumps and
motors in aluminium.



Double acting hydraulic hand pumps
with or without reservoir.



Filters : suction filters, return filters, in line filters spin-on
type, for medium and high pressure filters.



CASAPPA S.p.A. - Parma - Italy - Tel.: + 39 0521 304111 - Fax: + 39 0521 804600
CASAPPA Corp. - Batavia, IL 60510 U.S.A. - Phone: 630 761-0041 - Fax: 630 761-0048
CASAPPA GmbH - Plüderhausen - Germany - Tel.: + 49 (0)7181 989830 - Fax: + 49 (0)7181 989831
CASAPPA SARL - La Rochelle - France - Tel.: + 33 (0)5 46372433 - Fax: + 33 (0)5 46423907

www.casappa.com
e-mail: info@casappa.com