

<b>VERSION</b>	<b>W8</b>
Available for group:	
20	

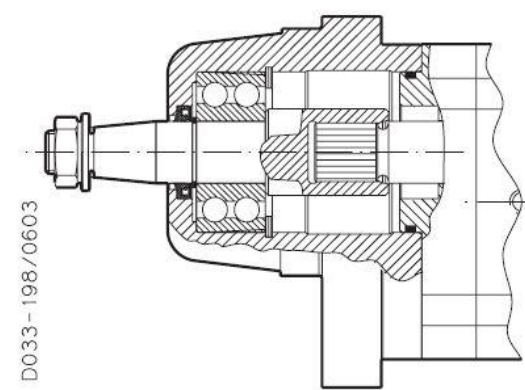

Series	Pump type PLP Motor type PLM	Displacement in <sup>3</sup> /rev (cm <sup>3</sup> /rev)	Max. pressure			Max. speed	Min. speed
			p <sub>1</sub>	p <sub>2</sub>	p <sub>3</sub>		
			psi (bar)				
<b>POLARIS 20</b>	<b>PL. 20•4</b>	0.30 (4,95)	3625 (250)	4060 (280)	4350 (300)	4000	600
	<b>PL. 20•6,3</b>	0.40 (6,61)	3625 (250)	4060 (280)	4350 (300)	4000	600
	<b>PL. 20•7,2</b>	0.44 (7,29)	3625 (250)	4060 (280)	4350 (300)	4000	600
	<b>PL. 20•8</b>	0.50 (8,26)	3625 (250)	4060 (280)	4350 (300)	3500	600
	<b>PL. 20•9</b>	0.56 (9,17)	3625 (250)	4060 (280)	4350 (300)	3500	600
	<b>PL. 20•10,5</b>	0.66 (10,9)	3625 (250)	4060 (280)	4350 (300)	3500	600
	<b>PL. 20•11,2</b>	0.69 (11,23)	3625 (250)	4060 (280)	4350 (300)	3500	600
	<b>PL. 20•14</b>	0.89 (14,53)	3625 (250)	4060 (280)	4350 (300)	3500	500
	<b>PL. 20•16</b>	1.03 (16,85)	3625 (250)	4060 (280)	4350 (300)	3000	500
	<b>PL. 20•19</b>	1.16 (19,09)	2900 (200)	3190 (220)	3480 (240)	3000	500
	<b>PL. 20•20</b>	1.29 (21,14)	2900 (200)	3190 (220)	3480 (240)	3000	500
	<b>PL. 20•24,5</b>	1.52 (24,84)	2465 (170)	2755 (190)	3045 (210)	2500	500
	<b>PL. 20•25</b>	1.61 (26,42)	2465 (170)	2755 (190)	3045 (210)	2500	500
	<b>PL. 20•27,8</b>	1.72 (28,21)	1885 (130)	2175 (150)	2465 (170)	2000	500
<b>PL. 20•31,5</b>	2.01 (33,03)	1885 (130)	2175 (150)	2465 (170)	2000	500	

**GERMAN TAPERED 1:5** **55**

Only for version 5, 9 and W8 with outboard bearing  
Mounting face refer to flange code **B2**

