

■ SU-IM-IE SUPPORTS AND CLUTCHES

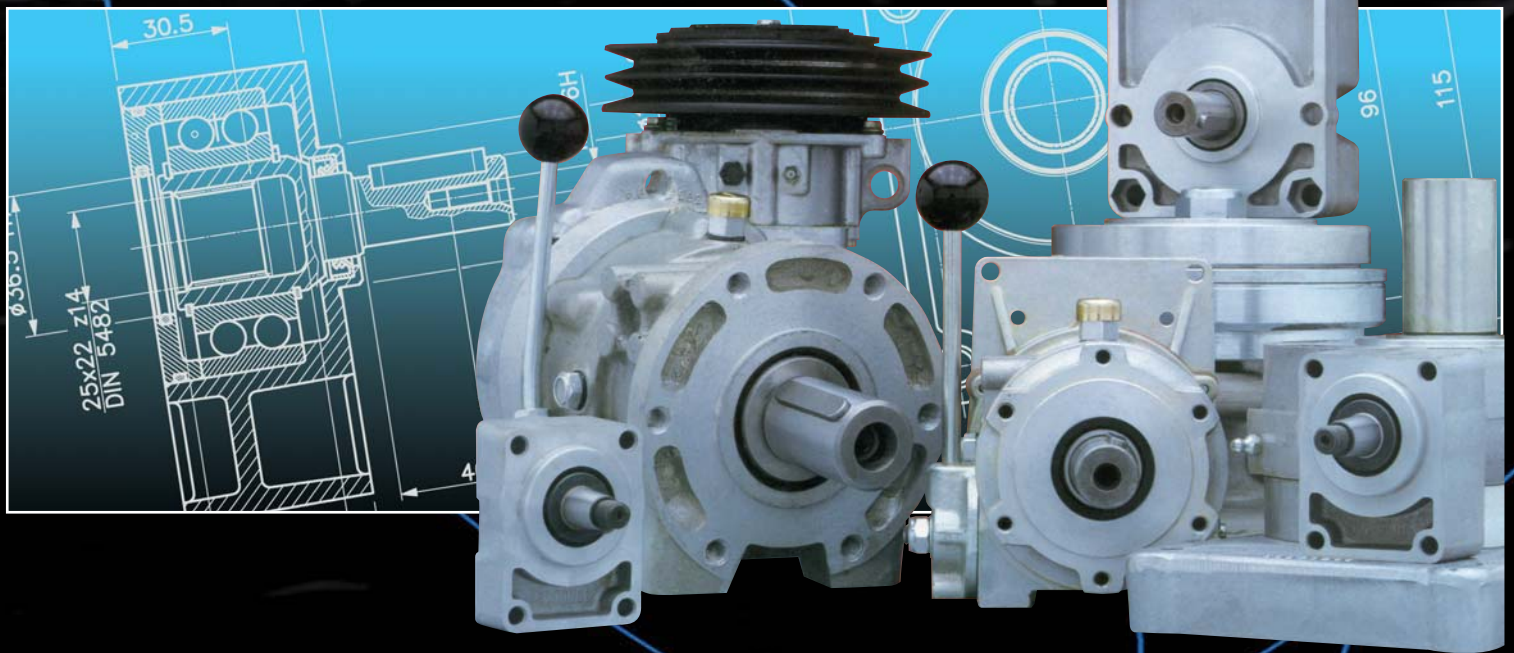

1 SUPPORTS

SU/1-C	Support with cylindrical shaft for pump GR.1	1.2
SU/1-D	Support with tapered shaft for pump GR.1	1.3
SU/2-C	Support with cylindrical shaft for pump GR.2	1.4
SU/2-D	Support with tapered shaft for pump GR.2	1.5
SUR/2-C	Reinforced support, cylindrical shaft for pump GR.2.....	1.6
SUR/2-D	Reinforced support, tapered shaft for pump GR.2.....	1.7
SU/3-C	Support with cylindrical shaft for pump GR.3	1.8
SU/3-D	Support with tapered shaft for pump GR.3	1.9
SU/3,5-C	Support with cylindrical shaft for pump GR.3.5	1.10
SU/3,5-D	Support with tapered shaft for pump GR.3.5	1.11
SU/Univ	Universale support, cylindrical shaft.....	1.12
SU/ZF-C	Support with cylindrical shaft for pump GR.2 BOSCH	1.13
SU/ZF-D	Support with tapered shaft for pump GR.2 BOSCH.....	1.14
SU/52-80-P	Support with tapered shaft for front flange GR.2 BOSCH	1.15
SU/52-80-R	Support with tapered shaft for front flange GR.2 BOSCH	1.16
SU/SAEA-R	Support with tapered shaft for front flange SAE A	1.17
SU/20-86-F	Support with tapered shaft for front flange GR.2	1.18
SU/20-86-E	Support with tapered shaft for front flange GR.2T	1.19
SU/20-86-H	Reinforced support, tapered shaft for front flange GR.2.....	1.20

2 MECHANICAL CLUTCHES

IM05	Mechanical clutch, cylindrical shaft flange for pump GR.1-2.....	2.1
IM1	Mechanical clutch, cylindrical shaft flange for pump GR.2-3/SAE A/SAE B	2.3
IM2	Mechanical clutch, cylindrical shaft.....	2.5
IM2 Univ	Mechanical clutch, DIN 5482 Z24 shaft.....	2.7

3 ELECTROMAGNETIC CLUTCHES

IE	Electromagnetic clutch - OIL LUBRICATION.....	3.1
IEG	Electromagnetic clutch - GREASE LUBRICATION	3.3

4 FLANGES

SU/IM2	Flanges for SU/UNIVERSALE - IM2 - IM2/UNIVERSALE	4.1
IM1/IE	Flanges for IM1 - IE (oil lubrication).....	4.2
IM05	Flanges for IM05	4.2
IEG	Flanges for IEG (grease lubrication)	4.2

SUPPORT WITH CYLINDRICAL SHAFT FOR PUMP GR.1

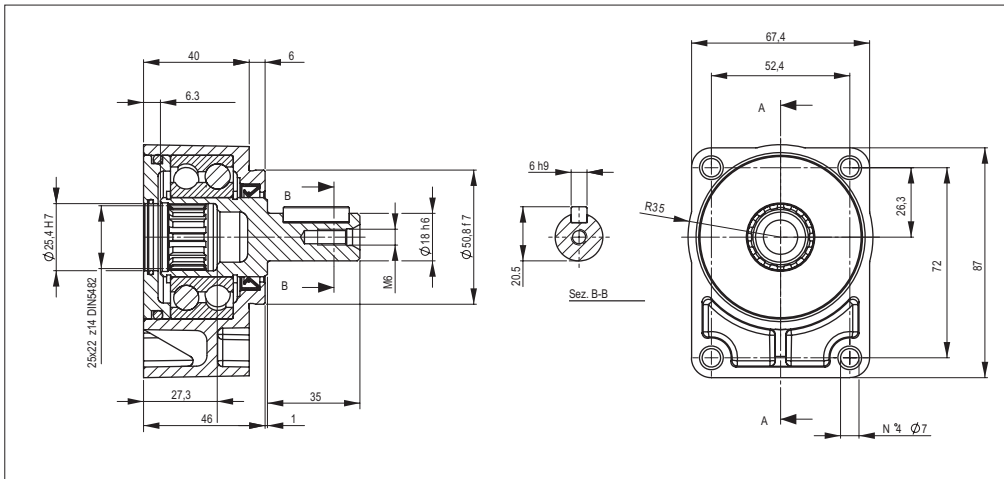

The SU/1-C, is suitable for driving Gr.1 hydraulic pumps and motors, with belts, chain or other transmission, in which heavy combined loads take place (axial and radial).
The pump/motor Gr. 1, is directly flanged and connected by splined coupling (coupling to be ordered separately).

MAXIMUM LOAD ON THE SHAFT

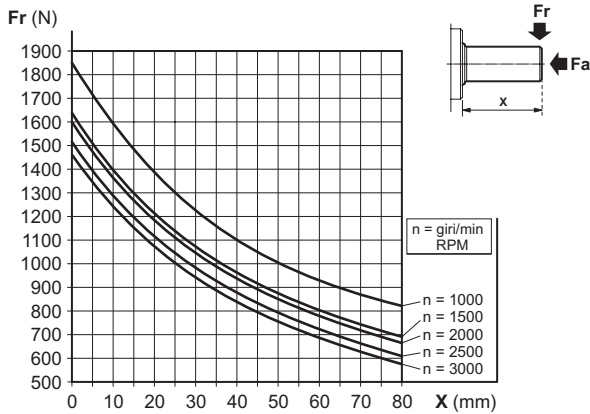

FEATURES

Minimum radial load	Fr = 130 N
Axial load	Fa ≤ Fr • 0,8
Max. revolutions per minute	4000 RPM
Life	3500 hours
Max. working temperature	70 °C
Grease quantity	10 ÷ 12 gr
Type of grease	DIN 51818 NLGI classe 2

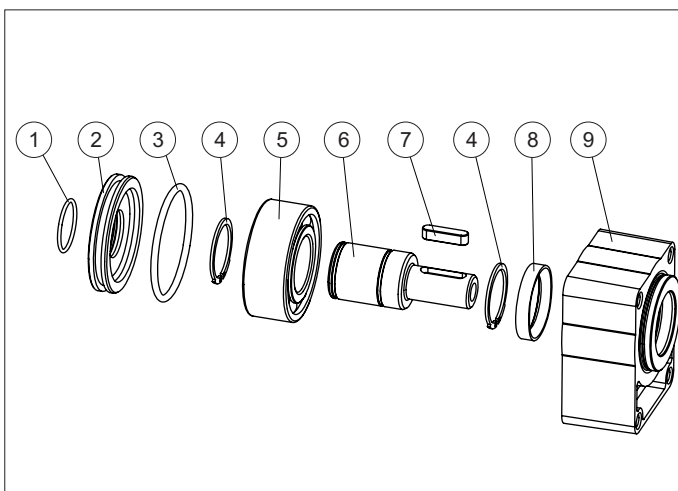

SPARE PARTS

Ref.	Code	Description	Q.ty
1	Q25830030	O-Ring 25.12x1.78	1
2	39000500	Cover	1
3	Q25830215	O-Ring 55.56x3.53	1
4	Q27150300	Snap ring E30	2
5	44005200	Bearing 3206 30x62x23.8	1
6	34200400	Cylindrical shaft	1
7	Q27470206	Woodruff A6x6x25	1
8	44101800	Shaft seal 30x40x7	1
9	39000400	Body	1

ORDERING CODE

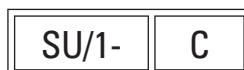

SU/1 = Belt pulley support

Series

C = Cylindrical shaft

SUPPORT WITH TAPERED SHAFT FOR PUMP GR.1

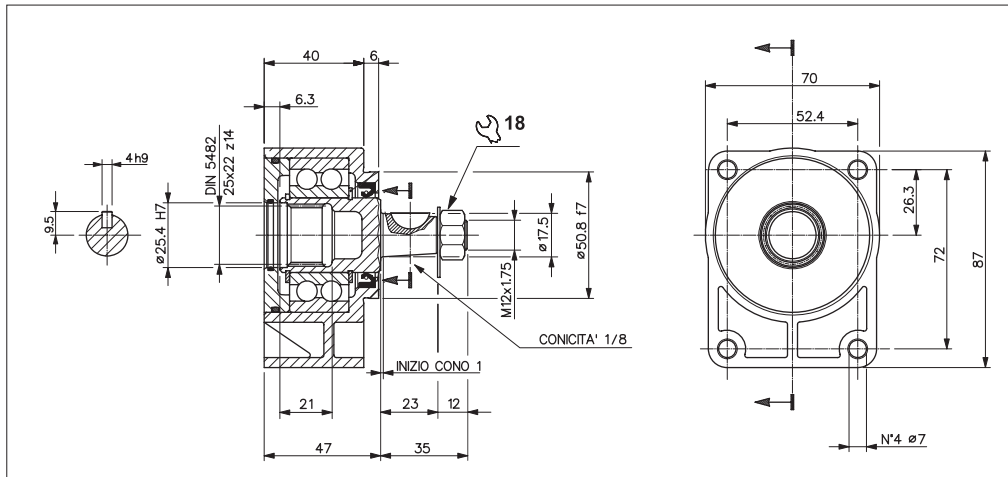

The SU/1-D, is suitable for driving Gr.1 hydraulic pumps and motors, with belts, chain or other transmission, in which heavy combined loads take place (axial and radial).
The pump/motor Gr. 1, is directly flanged and connected by splined coupling (coupling to be ordered separately).

MAXIMUM LOAD ON THE SHAFT

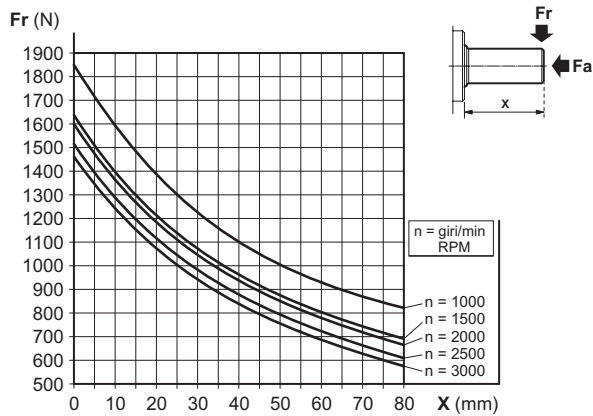

FEATURES

Minimum radial load	Fr = 130 N
Axial load	Fa ≤ Fr • 0,8
Max. revolutions per minute	4000 RPM
Life	3500 hours
Max. working temperature	70 °C
Grease quantity	10 ÷ 12 gr
Type of grease	DIN 51818 NLGI classe 2

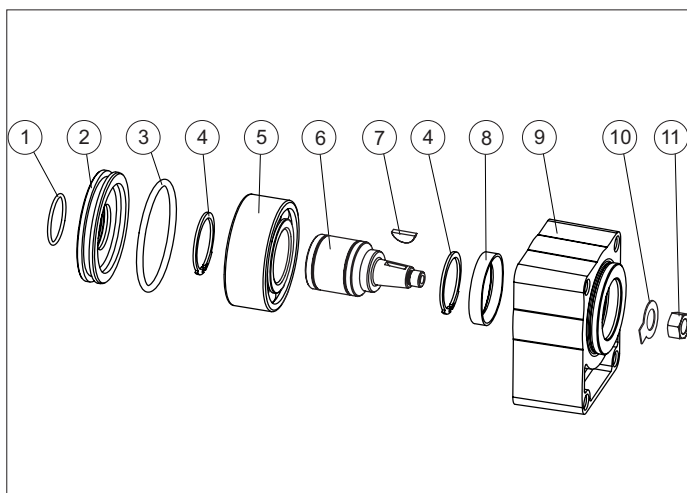

SPARE PARTS

Ref.	Code	Description	Q.ty
1	Q25830030	O-Ring 25.12x1.78	1
2	39000500	Cover	1
3	Q25830215	O-Ring 55.56x3.53	1
4	Q27150300	Snap ring D.30	2
5	44005200	Bearing 3206 30x62x23.8	1
6	34200500	Tapered shaft	1
7	Q27500072	Woodruff 4x6.5	1
8	44101800	Shaft seal 30x40x7	1
9	39000400	Body	1
10	42101400	Washer	1
11	Q26514070	Nut M12	1

ORDERING CODE

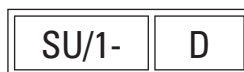

SU/1 = Belt pulley support

Series

D = Tapered shaft

SUPPORT WITH CYLINDRICAL SHAFT FOR PUMP GR.2

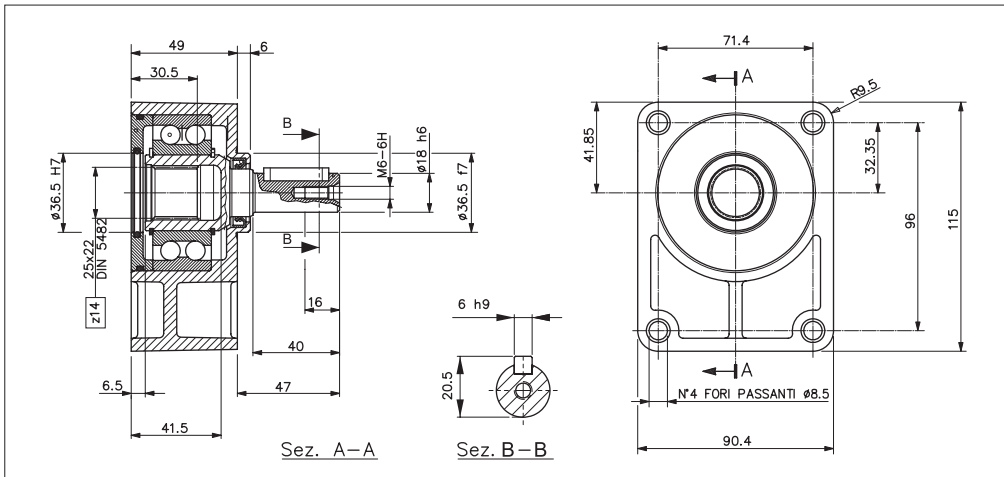

The SU/2-C, is suitable for driving Gr.2 hydraulic pumps and motors, with belts, chain or other transmission, in which heavy combined loads take place (axial and radial). The pump/motor Gr. 2, is directly flanged and connected by splined coupling (coupling to be ordered separately).

MAXIMUM LOAD ON THE SHAFT

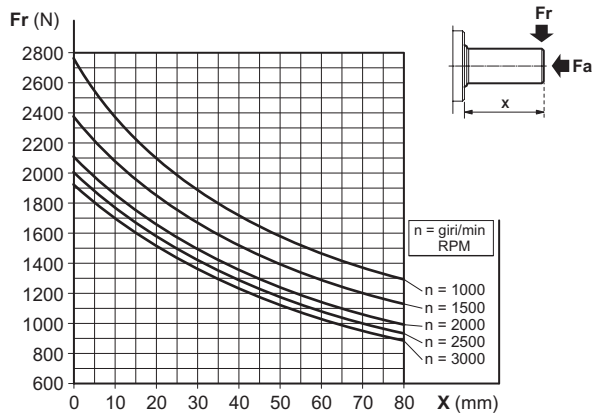

FEATURES

Minimum radial load	Fr = 155 N
Axial load	Fa ≤ Fr • 0,8
Max. revolutions per minute	4000 RPM
Life	3500 hours
Max. working temperature	70 °C
Grease quantity	16.5 ÷ 20.5 gr
Type of grease	DIN 51818 NLGI classe 2

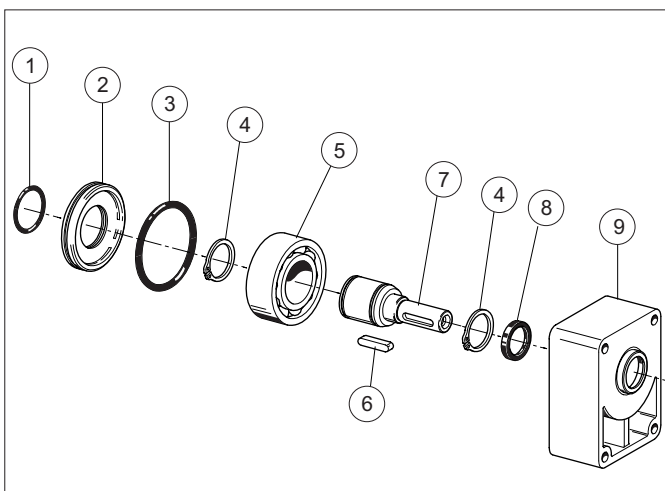

SPARE PARTS

Ref.	Code	Description	Q.ty
1	Q25830112	O-Ring 36,17x2,62	1
2	39003700	Cover	1
3	Q25830133	O-Ring 64,77x2,62	1
4	Q27150350	Snap ring E35	2
5	44005300	Bearing 3207 35x72x27	1
6	Q27470211	Woodruff A 6x6x30	1
7	34203300	Cylindrical shaft	1
8	44101900	Shaft seal 22x32x6	1
9	39003500	Body	1

ORDERING CODE

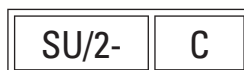

SU/2 = Belt pulley support

Series

C = Cylindrical shaft

SUPPORT WITH TAPERED SHAFT FOR PUMP GR.2

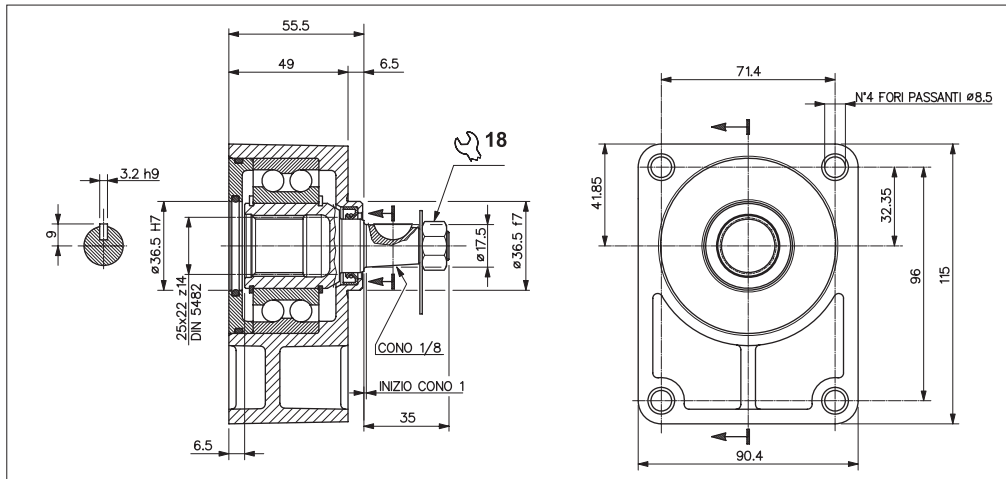

The SU/2-D (tapered shaft), is suitable for driving Gr. 2 hydraulic pumps and motors, with belts, chain or other transmission, in which heavy combined loads take place (axial and radial). The pump/motor Gr. 2, is directly flanged and connected by splined coupling (coupling to be ordered separately).

MAXIMUM LOAD ON THE SHAFT

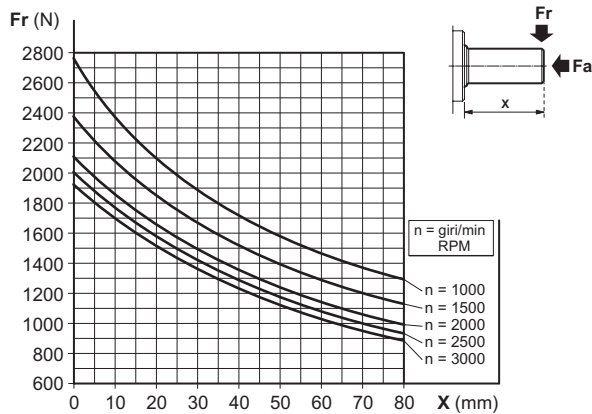

FEATURES

Minimum radial load	Fr = 155 N
Axial load	Fa ≤ Fr • 0,8
Max. revolutions per minute	4000 RPM
Life	3500 hours
Max. working temperature	70 °C
Grease quantity	16.5 ÷ 20.5 gr
Type of grease	DIN 51818 NLGI classe 2

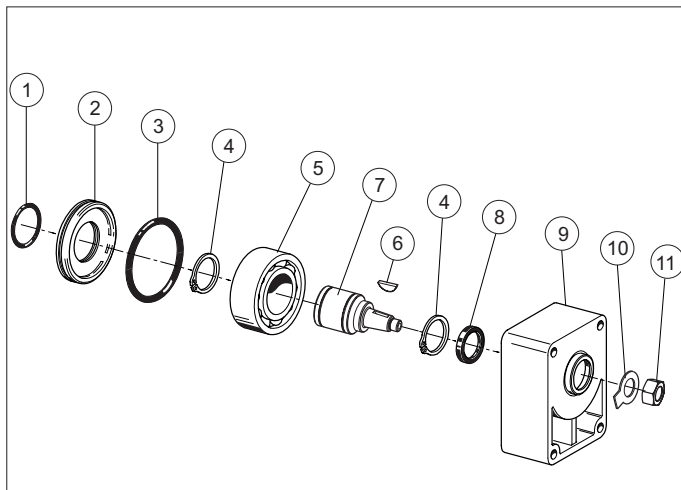

SPARE PARTS

Ref.	Code	Description	Q.ty
1	Q25830112	O-ring 36,14x2,62	1
2	39003700	Cover	1
3	Q25830133	O-ring 64,77x2,62	1
4	Q27150350	Snap ring D35	2
5	44005300	Bearing 3207 35x72x27	1
6	43203200	Woodruff 3,2x6,5	1
7	34221800	Tapered shaft	1
8	44101900	Shaft seal 22x32x6	1
9	39003500	Body	1
10	42101400	Washer	1
11	Q26514150	Nut M12x1,5	1

ORDERING CODE

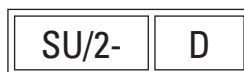

SU/2 = Belt pulley support

Series

D = Tapered shaft

REINFORCED SUPPORT, CYLINDRICAL SHAFT FOR PUMP GR.2

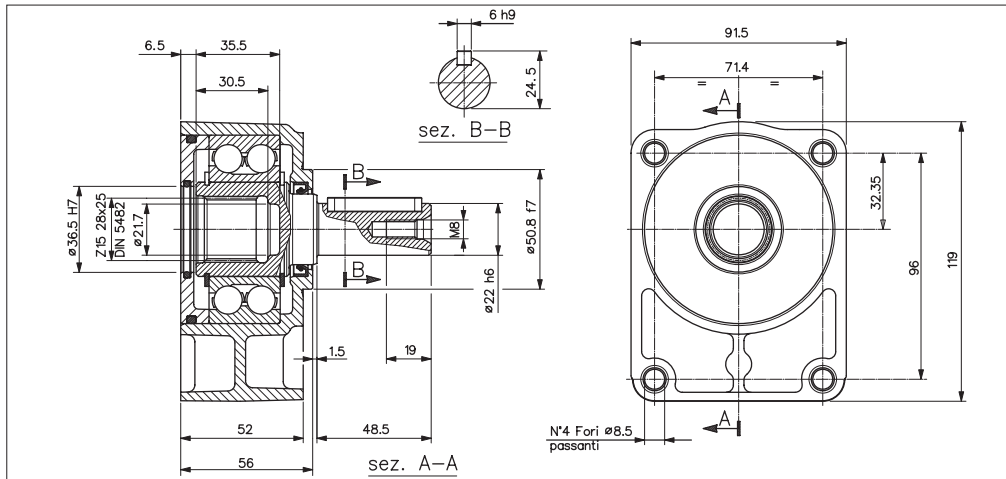

The SUR/2-C, is suitable for driving Gr. 2 hydraulic pumps and motors, with belts, chain or other transmission, in which heavy combined loads take place (axial and radial). The pump/motor Gr. 2, is directly flanged and connected by splined coupling (coupling to be ordered separately).

MAXIMUM LOAD ON THE SHAFT

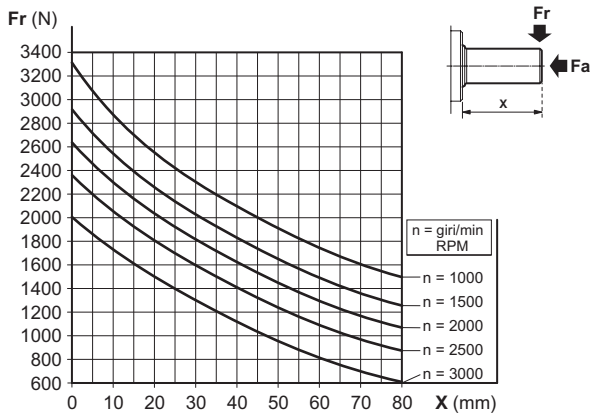

FEATURES

Minimum radial load	Fr = 277 N
Axial load	Fa ≤ Fr • 0,8
Max. revolutions per minute	3500 RPM
Life	3500 hours
Max. working temperature	70 °C
Grease quantity	24 ÷ 31.5 gr
Type of grease	DIN 51818 NLGI classe 2

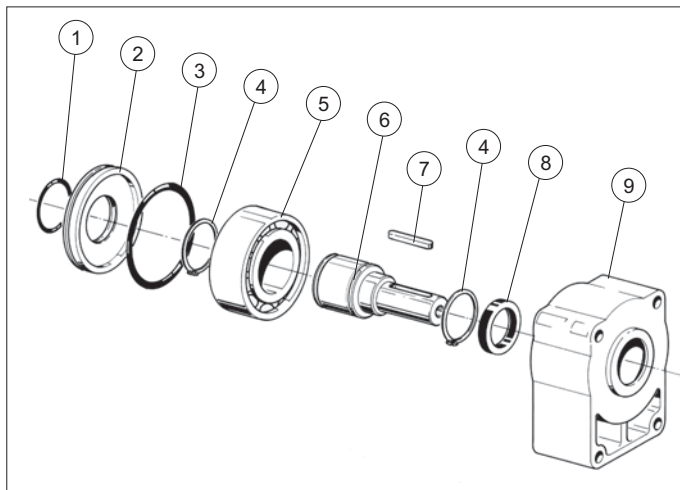

SPARE PARTS

Ref.	Code	Description	Q.ty
1	Q25830112	O-Ring 36.14x2.62	1
2	39003600	Reinforced cover	1
3	Q25830232	O-Ring 73.03x3.53	1
4	Q27150400	Snap ring E40	2
5	44005400	Bearing 3208 40x80x30.2	1
6	34200800	Cylindrical shaft	1
7	Q27470210	Woodruff A6x6x40	1
8	44101800	Shaft seal 30x40x7	1
9	39003400	Reinforced body	1

ORDERING CODE

SUR/2- C

SUR/2 = Belt pulley support

Series

C = Cylindrical shaft

REINFORCED SUPPORT, TAPERED SHAFT FOR PUMP GR.2

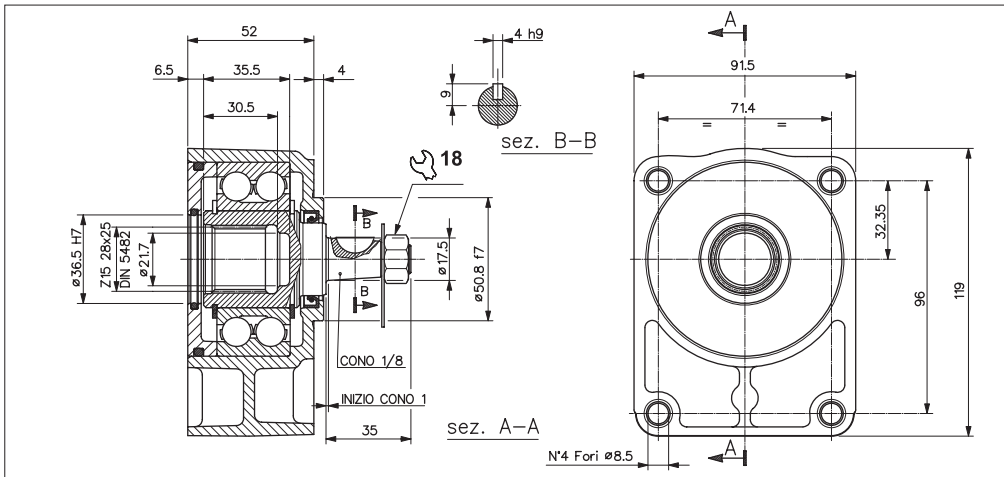

The SUR/2-D (reinforced support, tapered shaft), is suitable for driving Gr. 2 hydraulic pumps and motors, with belts, chain or other transmission, in which heavy combined loads take place (axial and radial). The pump/motor Gr. 2, is directly flanged and connected by splined coupling (coupling to be ordered separately).

MAXIMUM LOAD ON THE SHAFT

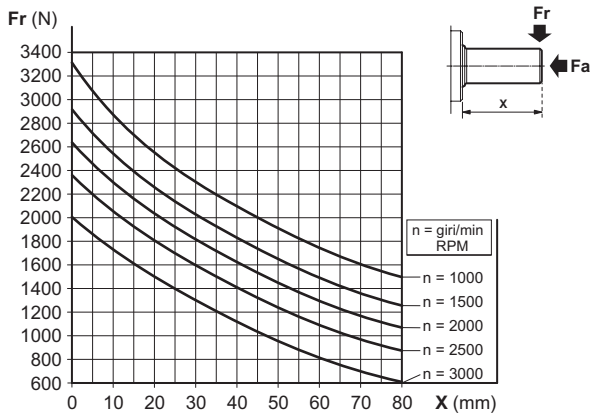

FEATURES

Minimum radial load	Fr = 277 N
Axial load	Fa ≤ Fr • 0,8
Max. revolutions per minute	3500 RPM
Life	3500 hours
Max. working temperature	70 °C
Grease quantity	24 ÷ 31.5 gr
Type of grease	DIN 51818 NLGI classe 2

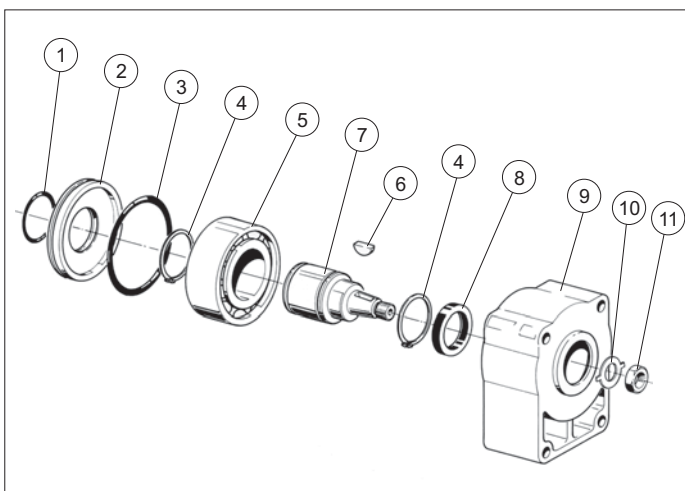

SPARE PARTS

Ref.	Code	Description	Q.ty
1	Q25830112	O-Ring 36.17x2.62	1
2	39003600	Reinforced cover	1
3	Q25830232	O-Ring 73.03x3.53	1
4	Q27150400	Snap ring D.40	2
5	44005400	Bearing 3208 40x80x30.2	1
6	Q27500072	Woodruff 4x6.5	1
7	34200900	Tapered shaft	1
8	44101800	Shaft seal 30x40x7	1
9	39003400	Reinforced body	1
10	42101400	Washer	1
11	Q26514150	Nut M12x1.5	1

ORDERING CODE

SUR/2- D

SUR/2 = Belt pulley support

Series

D = Tapered shaft

SUPPORT WITH CYLINDRICAL SHAFT FOR PUMP GR.3

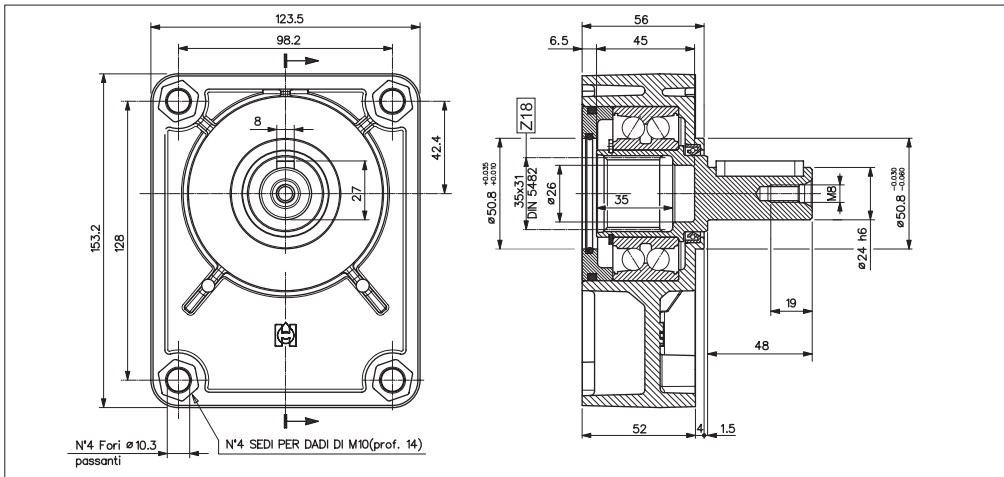

The SU/3-C, is suitable for driving Gr.3 hydraulic pumps and motors, with belts, chain or other transmission, in which heavy combined loads take place (axial and radial).
The pump/motor Gr. 3, is directly flanged and connected by splined coupling (coupling to be ordered separately).

MAXIMUM LOAD ON THE SHAFT

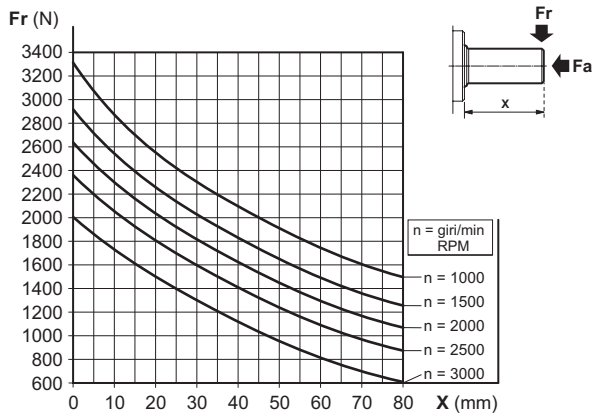

FEATURES

Minimum radial load	Fr = 277 N
Axial load	Fa ≤ Fr • 0,8
Max. revolutions per minute	3500 RPM
Life	3500 hours
Max. working temperature	70 °C
Grease quantity	19 ÷ 23.5 gr
Type of grease	DIN 51818 NLGI classe 2

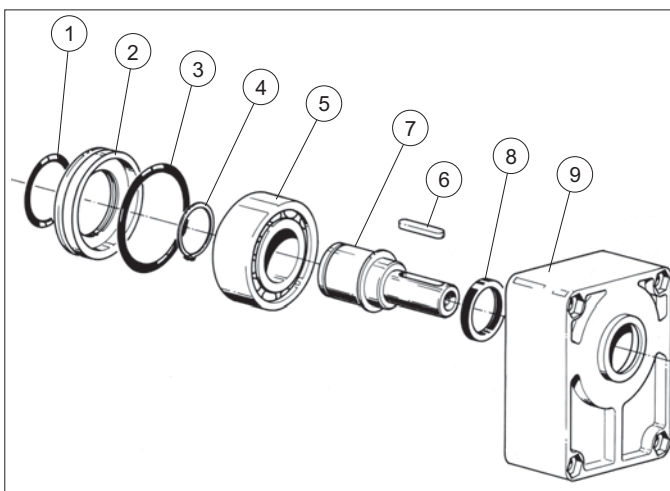

SPARE PARTS

Ref.	Code	Description	Q.ty
1	Q25830122	O-Ring 50.47x2.62	1
2	39025900	Cover	1
3	Q25830232	O-Ring 73.03x3.53	1
4	Q27150400	Snap ring E40	1
5	44005400	Bearing 3208 40x80x30.2	1
6	Q27470305	Woodruff A8x7x40	1
7	34215500	Cylindrical shaft	1
8	44104100	Shaft seal 45x35x7	1
9	39043700	Body	1

ORDERING CODE

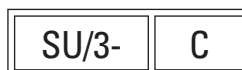

SU/3 = Belt pulley support

Series

C = Cylindrical shaft

SUPPORT WITH TAPERED SHAFT FOR PUMP GR.3

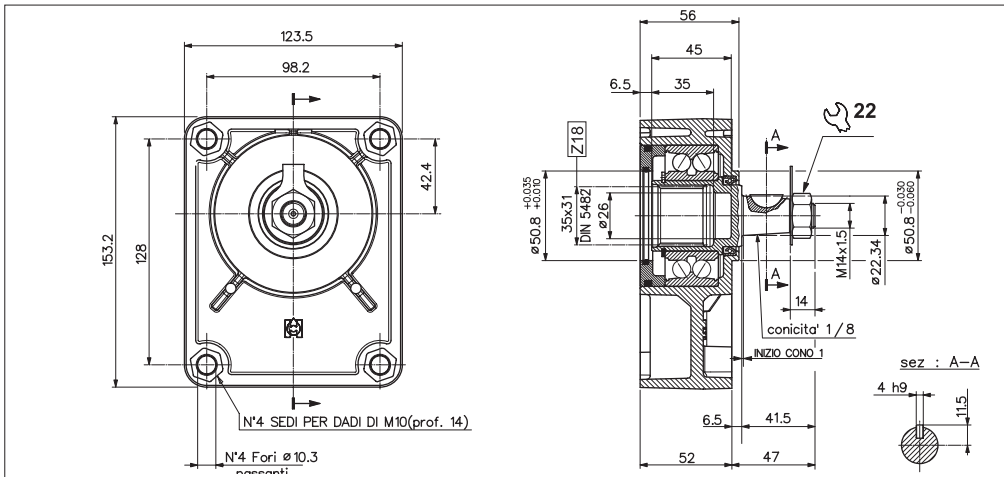

The SU/3-D (tapered shaft), is suitable for driving Gr. 3 hydraulic pumps and motors, with belts, chain or other transmission, in which heavy combined loads take place (axial and radial).

The pump/motor Gr. 3, is directly flanged and connected by splined coupling (coupling to be ordered separately).

MAXIMUM LOAD ON THE SHAFT

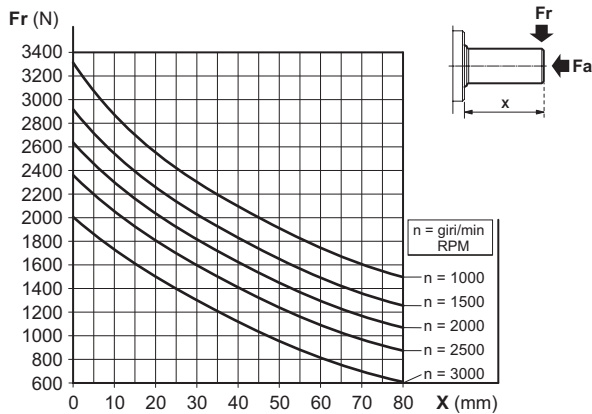

FEATURES

Minimum radial load	Fr = 277 N
Axial load	Fa ≤ Fr • 0,8
Max. revolutions per minute	3500 RPM
Life	3500 hours
Max. working temperature	70 °C
Grease quantity	19 ÷ 23.5 gr
Type of grease	DIN 51818 NLGI classe 2

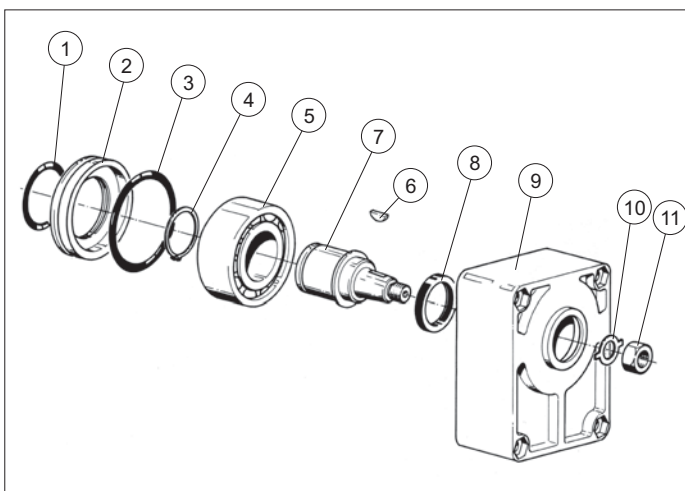

SPARE PARTS

Ref.	Code	Description	Q.ty
1	Q25830122	O-Ring 50.47x2.62	1
2	39025900	Cover	1
3	Q25830232	O-Ring 73.03x3.53	1
4	Q27150400	Snap ring E40	1
5	44005400	Bearing 3208 40x80x30.2	1
6	Q27500075	Woodruff 4x7.5	1
7	34215600	Tapered shaft	1
8	44104100	Shaft seal 45x35x7	1
9	39043700	Body	1
10	42101500	Washer	1
11	Q26514141	Nut M14x11x1.5	1

ORDERING CODE

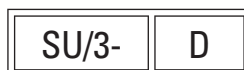

SU/3 = Belt pulley support

Series

D = Tapered shaft

SUPPORT WITH CYLINDRICAL SHAFT FOR PUMP GR.3.5

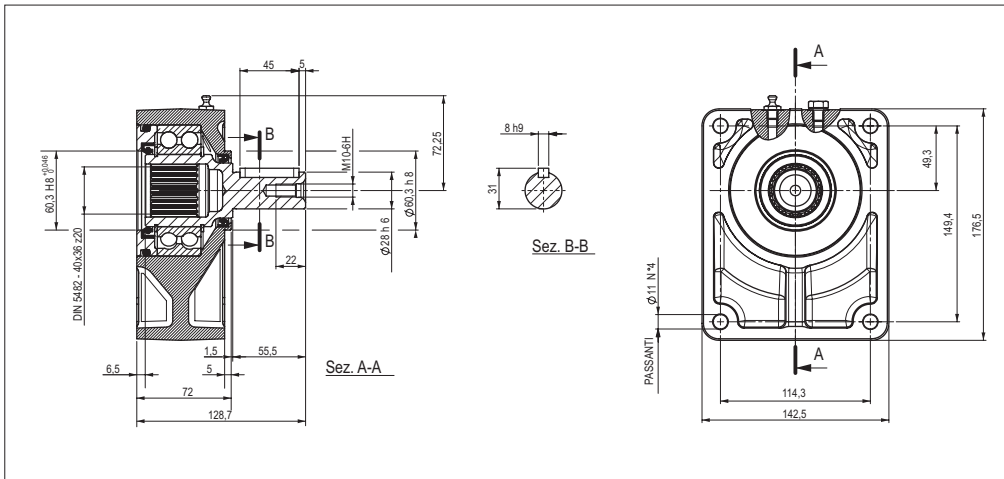

The SU/3.5-C (cylindrical shaft), is suitable for driving Gr. 3.5 hydraulic pumps and motors, with belts, chain or other transmission, in which heavy combined loads take place (axial and radial).

The pump/motor Gr. 3.5, is directly flanged and connected by splined coupling (coupling to be ordered separately).

On this version, there is a external grease nipple.

MAXIMUM LOAD ON THE SHAFT

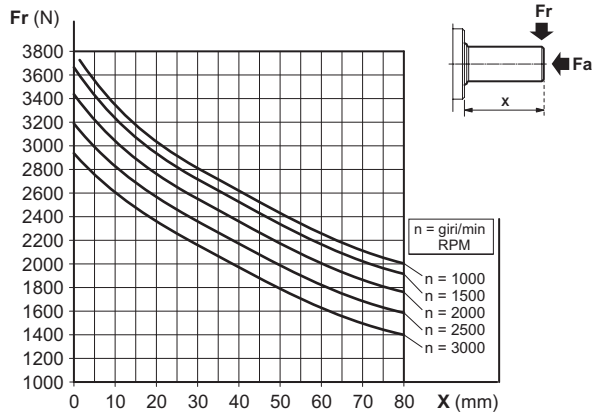

FEATURES

Minimum radial load	Fr = 476 N
Axial load	Fa ≤ Fr • 0,8
Max. revolutions per minute	3500 RPM
Life	3500 hours
Max. working temperature	70 °C
Grease quantity	24 ÷ 29 gr
Type of grease	DIN 51818 NLGI classe 2

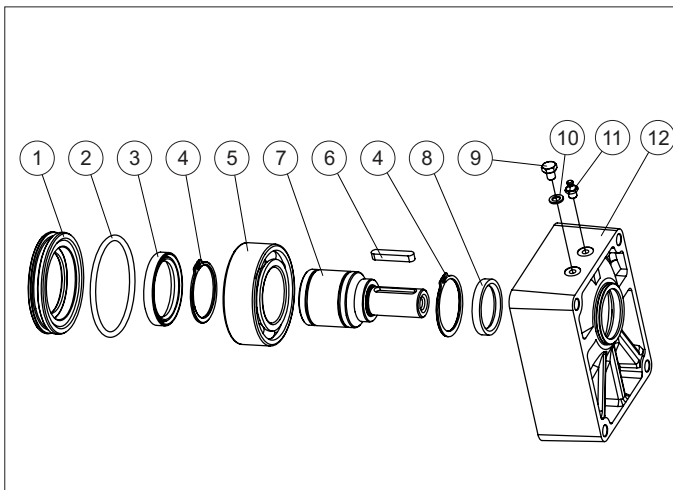

SPARE PARTS

Ref.	Code	Description	Q.ty
1	39022000	Cover	1
2	Q25830345	O-Ring OR185 89.69x5.33	1
3	44104800	Shaft seal 55x72x10	1
4	Q27150550	Snap ring E55	2
5	44003000	Bearing 3211 55x100x33.3	1
6	Q27470306	Woodruff A8x7x45	1
7	34217800	Tapered shaft	1
8	44105400	Shaft seal 42x55x8	1
9	Q26035090	Screw TEE M8x10	1
10	Q51437008	Aluminium washer 8.5x14x1.5	1
11	49101000	Grease nipple M8	1
12	39021900	Body	1

ORDERING CODE

SU/3,5- C

SU/3,5 = Belt pulley support

Series

C = Cylindrical shaft

SUPPORT WITH TAPERED SHAFT FOR PUMP GR.3.5

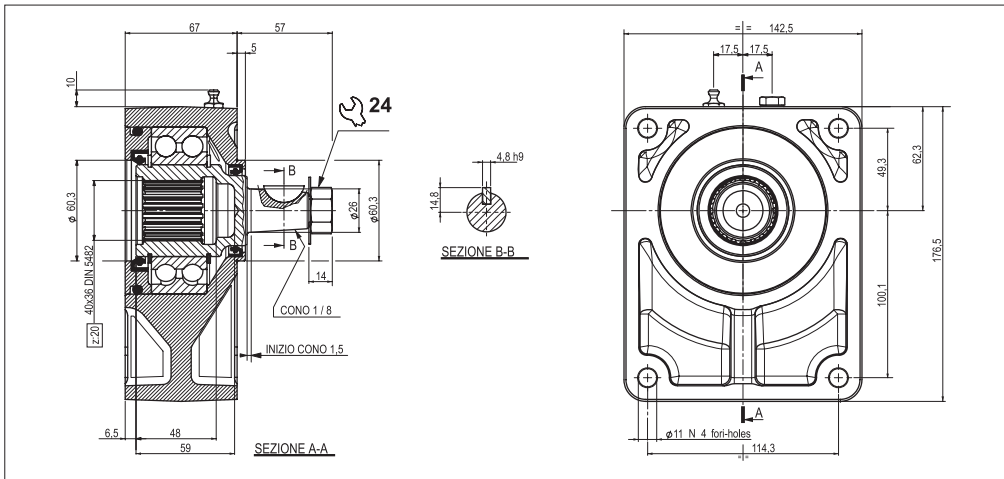

The SU/3.5-C, is suitable for driving Gr. 3.5 hydraulic pumps and motors, with belts, chain or other transmission, in which heavy combined loads take place (axial and radial). The pump/motor Gr. 3.5, is directly flanged and connected by splined coupling (coupling to be ordered separately). On this version, there is a external grease nipple.

MAXIMUM LOAD ON THE SHAFT

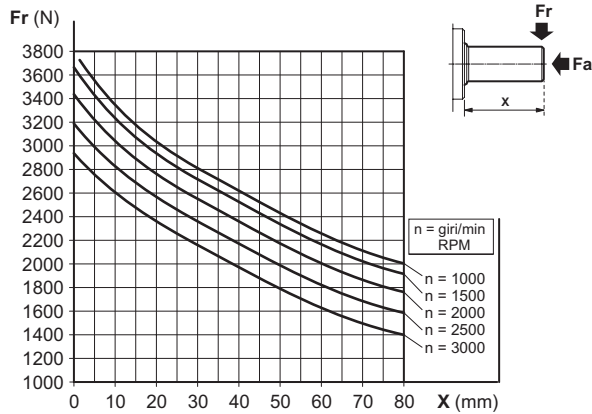

FEATURES

Minimum radial load	Fr = 476 N
Axial load	Fa ≤ Fr • 0,8
Max. revolutions per minute	3500 RPM
Life	3500 hours
Max. working temperature	70 °C
Grease quantity	24 ÷ 29 gr
Type of grease	DIN 51818 NLGI classe 2

Rif.	Codice	Descrizione	Q.tà
1	39022000	Cover	1
2	Q25830345	O-Ring 89.69x5.33	1
3	44104800	Shaft seal 55x72x10	1

SPARE PARTS

Rif.	Codice	Descrizione	Q.tà
4	Q27150550	Snap ring E55	2
5	44003000	Bearing 3211 55x100x33.3	1
6	43202200	Woodruff 4.8x10x25	1
7	34217900	Tapered shaft	1
8	44105400	Shaft seal 42x55x8	1
9	Q26035090	Screw TEE M8x10	1
10	Q51437008	Aluminium washer 8.5x14x1.5	1
11	49101000	Grease nipple M8	1
12	39021900	Body	1
13	42103500	Washer	1
14	Q26514142	Nut M16x1.5	1

ORDERING CODE

SU/3,5- D

SU/3,5 = Belt pulley support

Series

D = Tapered shaft

1

UNIVERSALE SUPPORT, CYLINDRICAL SHAFT

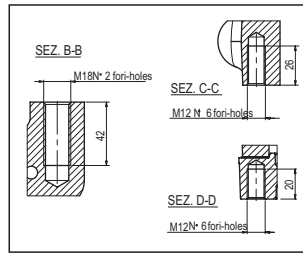
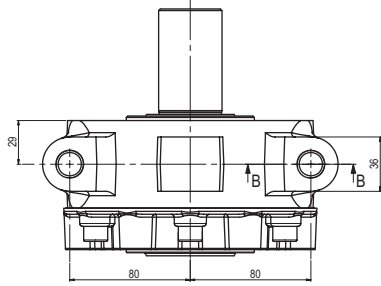

The SU/Universal is suitable for driving a variety of pumps, motors, with belts, chain or other transmission, in which heavy combined loads take place. Flanges and couplings are required to connect the hydraulic pump or motor.

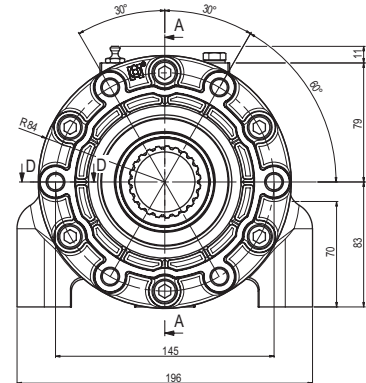
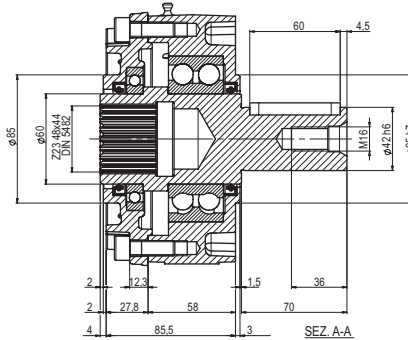
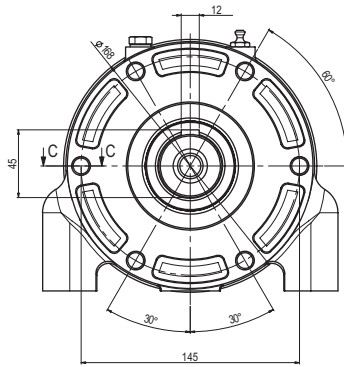

MAXIMUM LOAD ON THE SHAFT

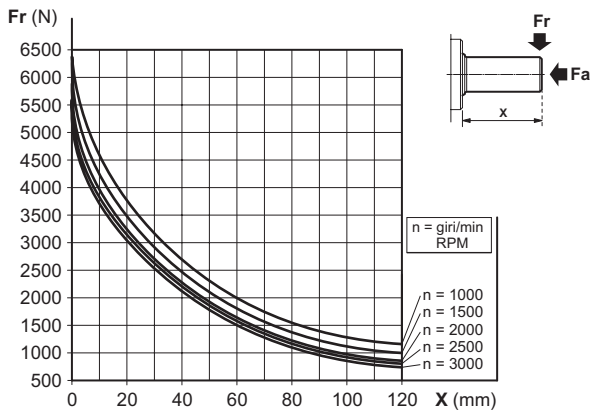

FEATURES

Minimum radial load	Fr = 450 N
Axial load	Fa ≤ Fr • 0,8
Max. revolutions per minute	3500 RPM
Life	3500 hours
Max. working temperature	70 °C
Grease quantity	81 ÷ 118.5 gr
Type of grease	DIN 51818 NLGI classe 2

SPARE PARTS

Ref.	Code	Description	Q.ty
1	39030400	Cover	1
2	39200200	Join	1
3	44103600	Shaft seal 60x75x8	2
4	44005900	Bearing 16012 60x95x11	1
5	34207400	Shaft	1
6	Q27470413	Woodruff A12x8x60	1
7	44006100	Bearing 3212 60x110x36.5	1
8	Q51437008	Aluminium washer 8.5x14x1.5	1
9	Q26035090	Screw TEE M8x10	1
10	49101000	Grease nipple M8	1
11	39009200	Body	1
12	Q26075125	Screw TCEI M10x30	6
13	—	Fange kit - sect. 4.1	1

ORDERING CODE

SU/UNIVERSALE

SU/UNIVERSALE = Belt pulley support

Series

Flanges sect. 4.1

A	SAE A	F	GR. 3.5
B	SAE B	G	GR. 4
C	SAE C	L	ISO 1
D	GR. 2	M	ISO 2
E	GR. 3	P	ISO 3

SUPPORT WITH CYLINDRICAL SHAFT FOR PUMP GR.2 BOSCH

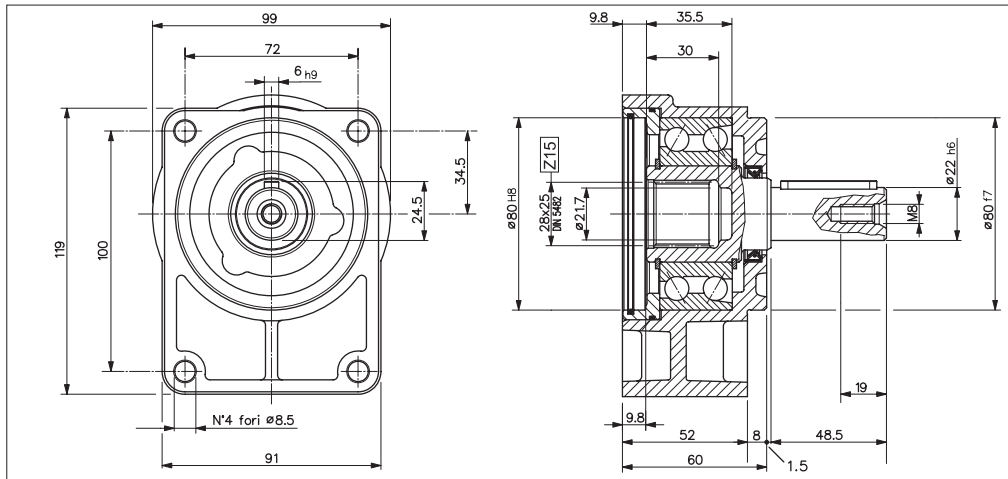

The SU/ZF-C is suitable for driving Gr.2 Bosch pumps and motors with belts, chain or other transmission, in which heavy combined loads take place (axial and radial).

The pump/motor Gr. 2 Bosch, is directly flanged and connected by splined coupling (coupling to be ordered separately).

MAXIMUM LOAD ON THE SHAFT

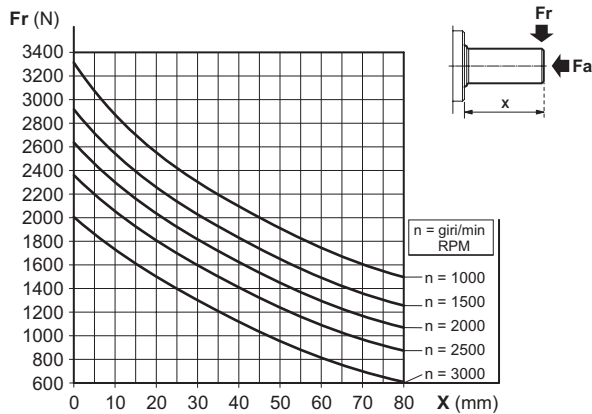

FEATURES

Minimum radial load	Fr = 277 N
Axial load	Fa ≤ Fr • 0,8
Max. revolutions per minute	3500 RPM
Life	3500 hours
Max. working temperature	70 °C
Grease quantity	21 ÷ 27 gr
Type of grease	DIN 51818 NLGI classe 2

SPARE PARTS

Ref.	Code	Description	Q.ty
1	Q25860041	O-Ring 80x2	1
2	Q25830056	O-Ring 82.27x1.78	1
3	39001800	Cover	1
4	Q27150400	Snap ring	2
5	44005400	Bearing 3208 40x80x30.2	1
6	34200800	Cylindrical shaft	1
7	Q27470210	Woodruff A6x6x40	1
8	44101800	Shaft seal 30x40x7	1
9	39001700	Body	1

ORDERING CODE

SU/ZF- C

SU/ZF = Belt pulley support

Series

C = Cylindrical shaft

SUPPORT WITH TAPERED SHAFT FOR PUMP GR.2 BOSCH

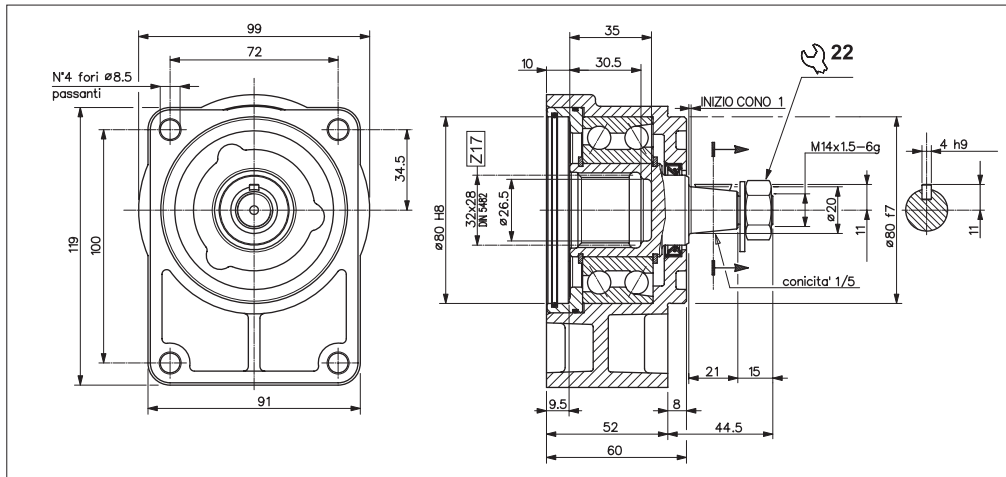

The SU/ZF-D is suitable for driving Gr.2 Bosch pumps and motors with belts, chain or other transmission, in which heavy combined loads take place (axial and radial).

The pump/motor Gr. 2 Bosch, is directly flanged and connected by splined coupling (coupling to be ordered separately).

MAXIMUM LOAD ON THE SHAFT

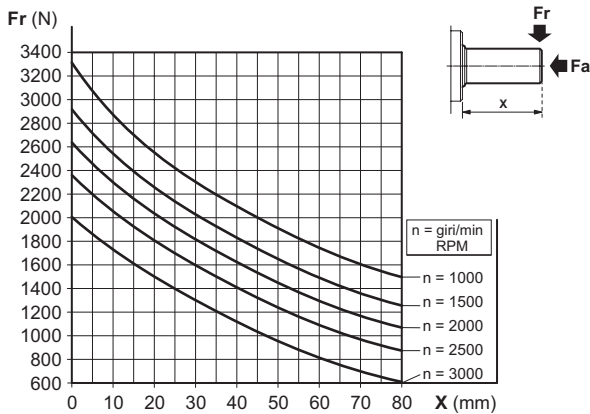

FEATURES

Minimum radial load	Fr = 277 N
Axial load	Fa ≤ Fr • 0,8
Max. revolutions per minute	3500 RPM
Life	3500 hours
Max. working temperature	70 °C
Grease quantity	21 ÷ 27 gr
Type of grease	DIN 51818 NLGI classe 2

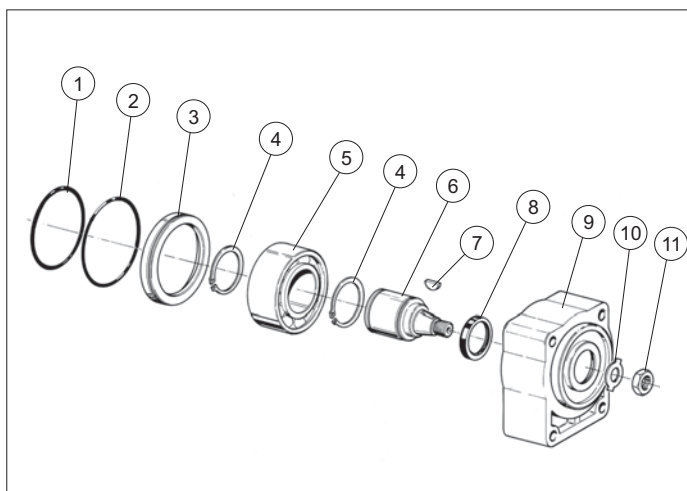

SPARE PARTS

Ref.	Code	Description	Q.ty
1	Q25860041	O-Ring 80x2	1
2	Q25830056	O-Ring 82.27x1.78	1
3	39001800	Cover	1
4	Q27150400	Snap ring D.40	2
5	44005400	Bearing 3208 40x80x30.2	1
6	34201500	Tapered shaft	1
7	Q27500072	Woodruff 4x6,5	1
8	44101800	Shaft seal 30x40x7	1
9	39001700	Body	1
10	42101500	Washer	1
11	Q26514141	Nut M14x1,5	1

ORDERING CODE



SU/ZF = Belt pulley support

Series

D = Tapered shaft

SUPPORT WITH TAPERED SHAFT FOR FRONT FLANGE GR.2 BOSCH

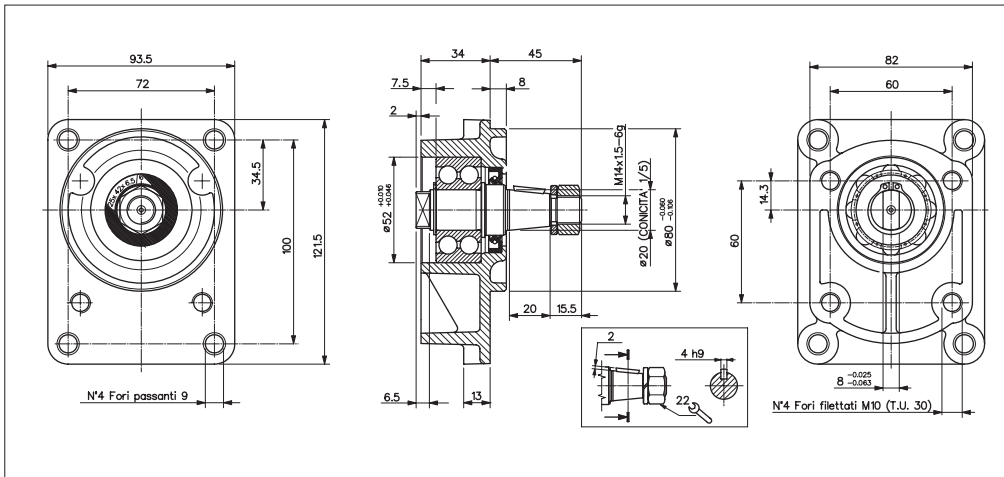

The SU/52-80-P is suitable for driving non-standard Gr. 2 pumps and motors with belts, chain or other transmission, in which heavy combined loads take place (axial and radial).
The pump/motor Gr. 2, is directly flanged and connected by tang shaft for Oldam coupling (coupling not supplied).

MAXIMUM LOAD ON THE SHAFT

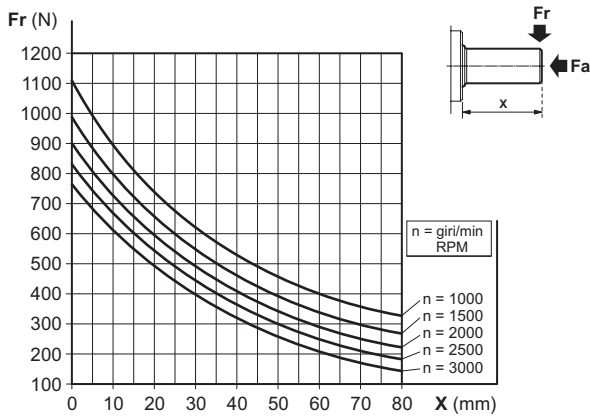

FEATURES

Minimum radial load	Fr = 90 N
Axial load	Fa ≤ Fr • 0,8
Max. revolutions per minute	4000 RPM
Life	3500 hours
Max. working temperature	70 °C
Grease quantity	8 ÷ 9.5 gr
Type of grease	DIN 51818 NLGI classe 2

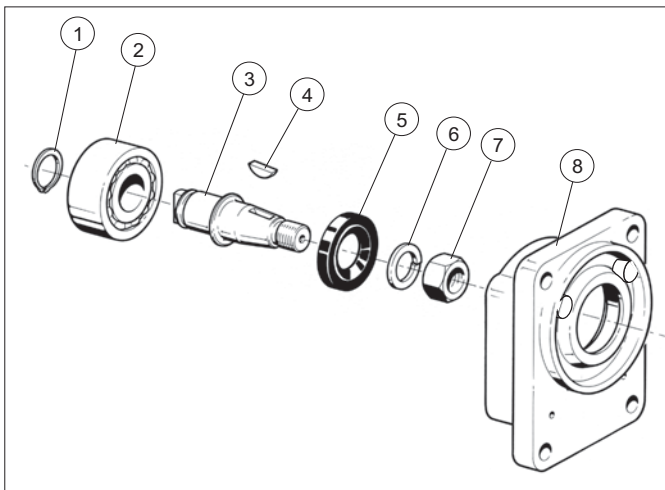

SPARE PARTS

Ref.	Code	Description	Q.ty
1	Q27150200	Snap ring D.20	1
2	44004000	Bearing 3304 20x52x22.2	1
3	34230300	Shaft	1
4	Q27500072	Woodruff 4x6.5	1
5	44117600	Shaft seal 25x42x6/6.5	1
6	Q26843022	Washer 15x24x3	1
7	Q26514141	Nut M14x1.5	1
8	39034700	Body	1

ORDERING CODE

SU/52-80 P

SU/52-80 = Belt pulley support

Series

P = Tapered shaft

1

SUPPORT WITH TAPERED SHAFT FOR FRONT FLANGE GR.2 BOSCH

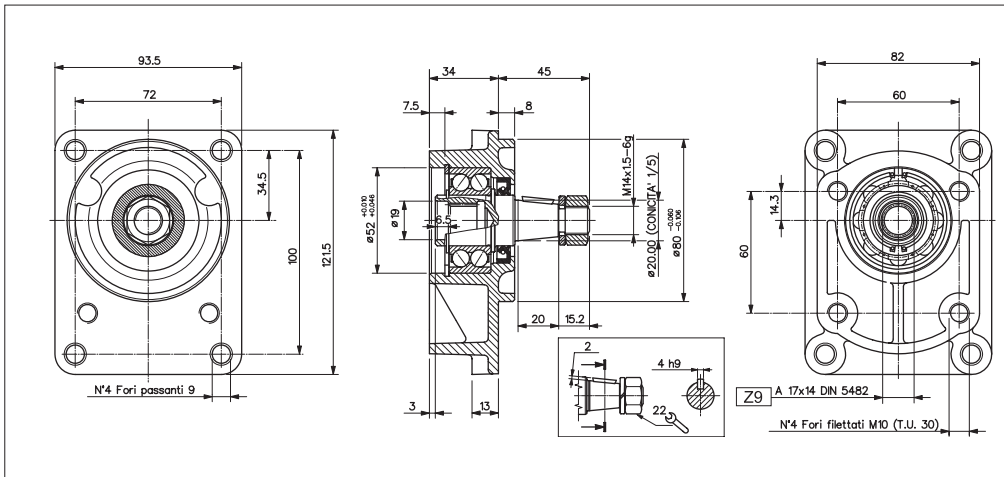

The SU/52-80-R is suitable for driving non-standard Gr. 2 pumps and motors with belts, chain or other transmission, in which heavy combined loads take place (axial and radial).

The pump/motor Gr. 2, is directly flanged and connected by splined coupling (coupling to be ordered separately).

MAXIMUM LOAD ON THE SHAFT

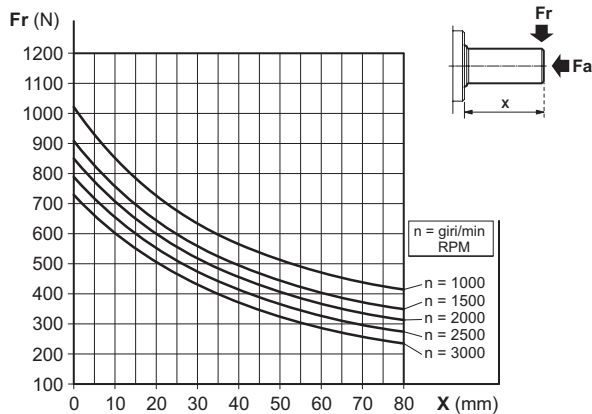

FEATURES

Minimum radial load	Fr = 90 N
Axial load	Fa ≤ Fr • 0,8
Max. revolutions per minute	4000 RPM
Life	3500 hours
Max. working temperature	70 °C
Grease quantity	8 ÷ 9.5 gr
Type of grease	DIN 51818 NLGI classe 2

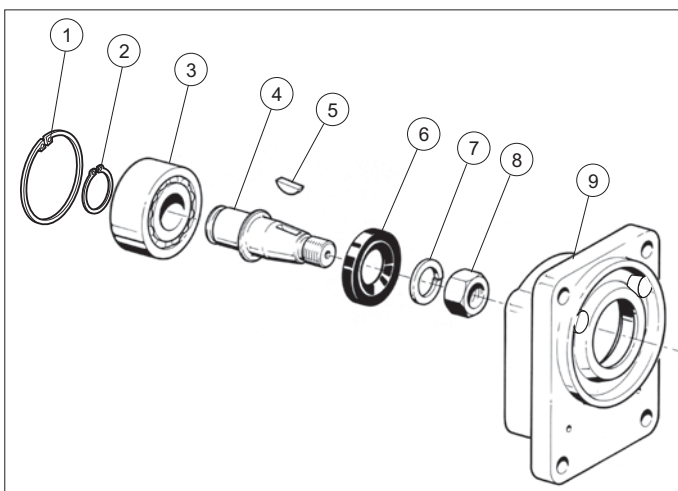

SPARE PARTS

Ref.	Code	Description	Q.ty
1	Q27160052	Seeger D.52	1
2	Q27150250	Seeger D.25	1
3	44004100	Bearing 25x52x20.6	1
4	34242500	Shaft	1
5	Q27500072	Woodruff 4x6.5	1
6	44117600	Shaft seal 25x42x6/6.5	1
7	Q26843022	Washer 15x24x3	1
8	Q26514141	Nut M14x1.5	1
9	39043500	Body	1

ORDERING CODE

SU/52-80 R

SU/52-80 = Belt pulley support

Series

R = Tapered shaft

SUPPORT WITH TAPERED SHAFT FOR FRONT FLANGE SAE A

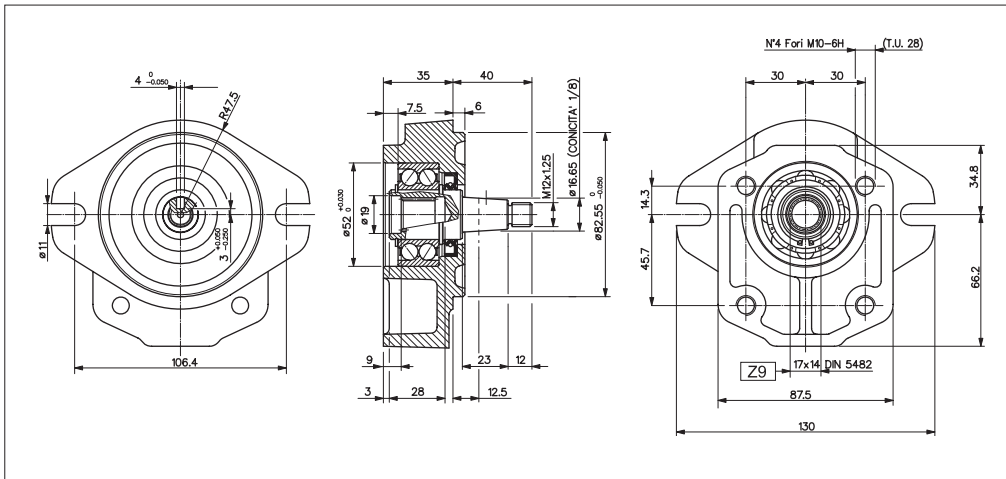

The SU/SAEA-R is suitable for driving non-standard Gr. 2 pumps and motors with belts, chain or other transmission, in which heavy combined loads take place (axial and radial).

The pump/motor Gr. 2, is directly flanged and connected by splined coupling (coupling to be ordered separately).

MAXIMUM LOAD ON THE SHAFT

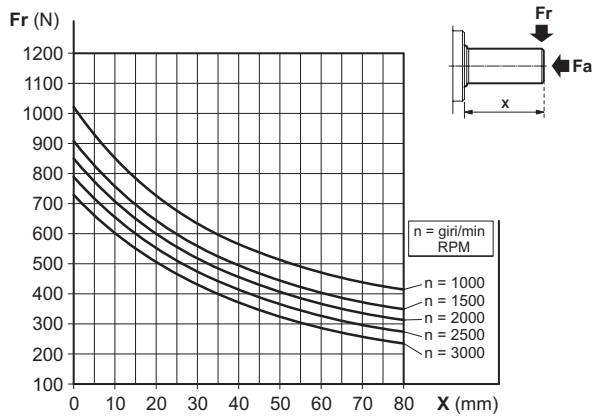

FEATURES

Minimum radial load	Fr = 100 N
Axial load	Fa ≤ Fr • 0,8
Max. revolutions per minute	4000 RPM
Life	3500 hours
Max. working temperature	70 °C
Grease quantity	8.5 ÷ 10 gr
Type of grease	DIN 51818 NLGI classe 2

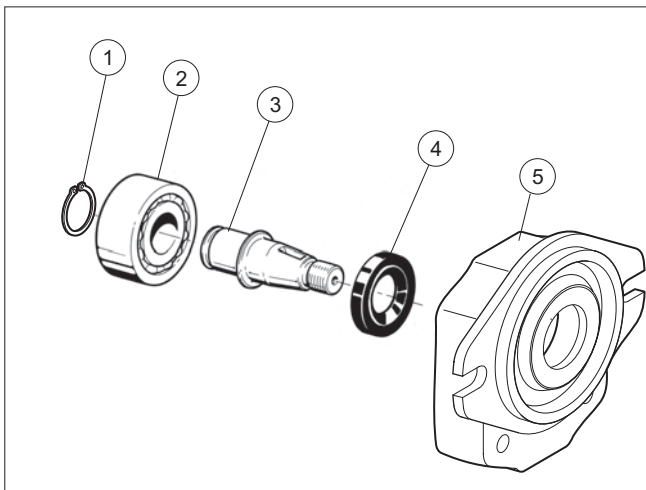

SPARE PARTS

Ref.	Code	Description	Q.ty
1	Q27150250	Snap ring D.25	1
2	44004100	Bearing 3205 25x52x20.6	1
3	34252900	Shaft Gr.2	1
4	44117600	Shaft seal 25x42x6	1
5	39035300	Body	1

ORDERING CODE

SU/SAEA- R

SU/SAEA = Belt pulley support

Series

R = Tapered shaft

1

SUPPORT WITH TAPERED SHAFT FOR FRONT FLANGE GR.2

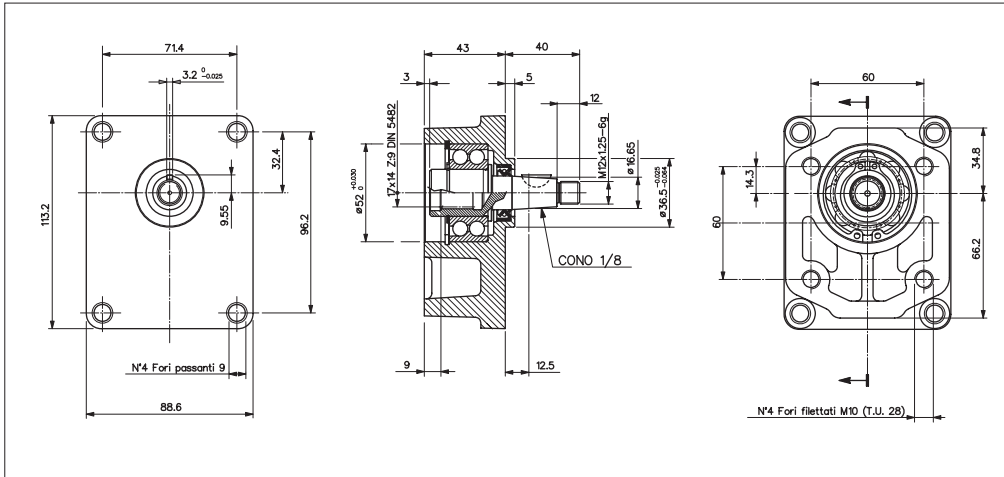

The SU/20-86-F is suitable for driving non-standard Gr. 2 pumps and motors with belts, chain or other transmission, in which heavy combined loads take place (axial and radial). The pump/motor Gr. 2, is directly flanged and connected by splined coupling (coupling to be ordered separately).

MAXIMUM LOAD ON THE SHAFT

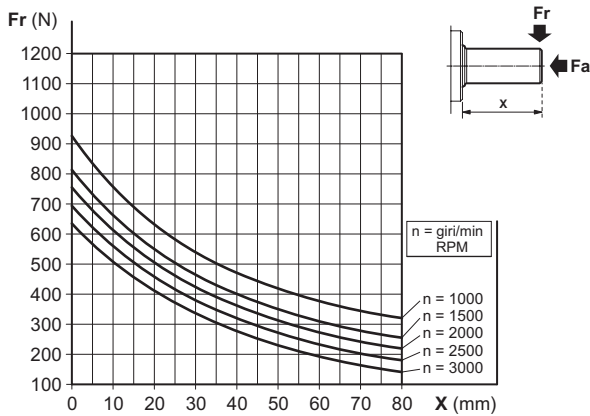

FEATURES

Minimum radial load	Fr = 100 N
Axial load	Fa ≤ Fr • 0,8
Max. revolutions per minute	4000 RPM
Life	3500 hours
Max. working temperature	70 °C
Grease quantity	10 ÷ 13 gr
Type of grease	DIN 51818 NLGI classe 2

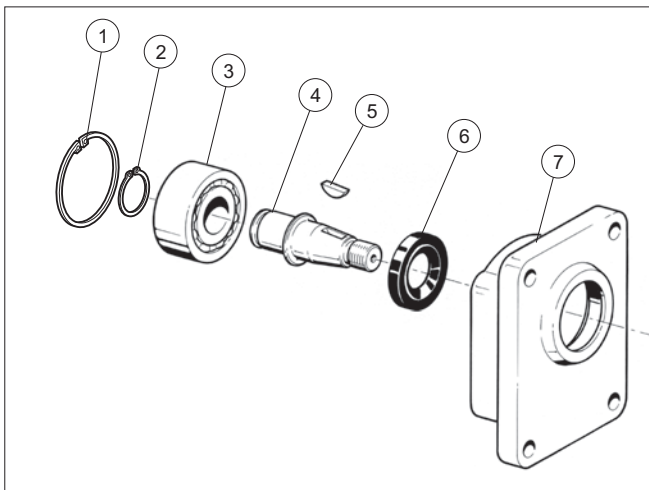

SPARE PARTS

Ref.	Code	Description	Q.ty
1	Q27150250	Snap ring D.25	1
2	Q27160052	Snap ring D.52	1
3	44004100	Bearing 3205 25x52x20.6	1
4	34238000	Shaft Gr.2	1
5	43203200	Woodruff 3.2x6.5	1
6	44113500	Shaft seal 18x30x7/7.5	1
7	39040000	Body	1

ORDERING CODE

SU/20-86- F

SU/20-86 = Belt pulley support

Series

F = Tapered shaft

SUPPORT WITH TAPERED SHAFT FOR FRONT FLANGE GR.2T

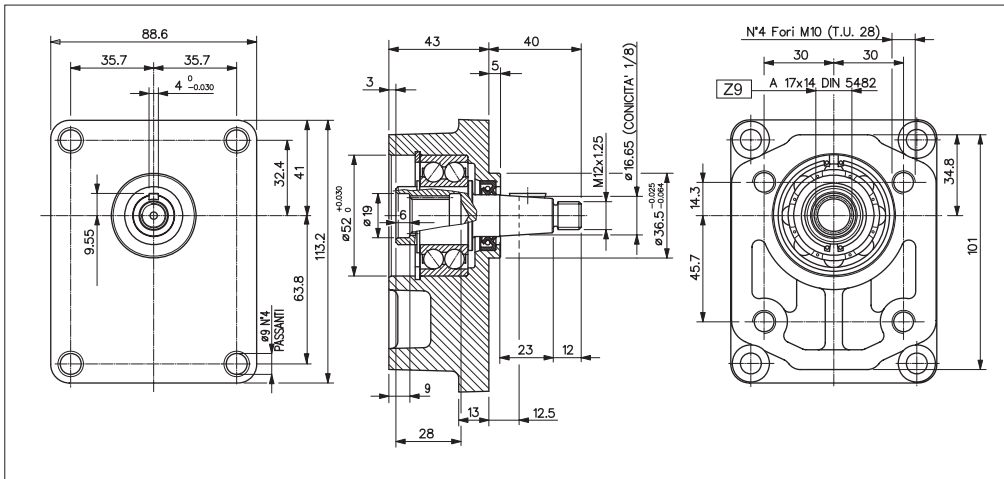

The SU/20-86-E is suitable for driving non-standard Gr. 2 pumps and motors with belts, chain or other transmission, in which heavy combined loads take place (axial and radial). The pump/motor Gr. 2, is directly flanged and connected by splined coupling (coupling to be ordered separately).

MAXIMUM LOAD ON THE SHAFT

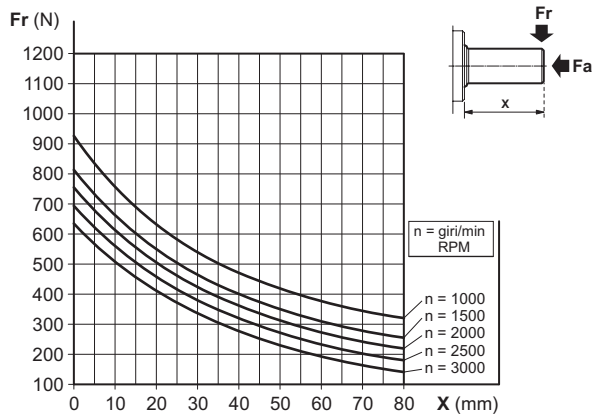

FEATURES

Minimum radial load	Fr = 100 N
Axial load	Fa ≤ Fr • 0,8
Max. revolutions per minute	4000 RPM
Life	3500 hours
Max. working temperature	70 °C
Grease quantity	10 ÷ 13 gr
Type of grease	DIN 51818 NLGI classe 2

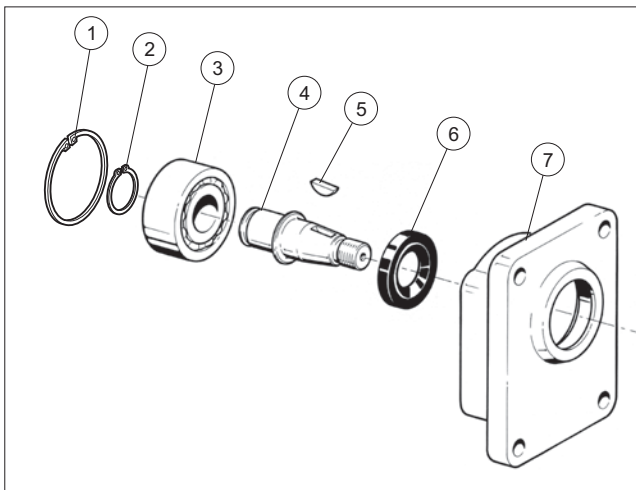

SPARE PARTS

Ref.	Code	Description	Q.ty
1	Q27160052	Snap ring D.52	1
2	Q27150250	Snap ring D.25	1
3	44004100	Bearing 25x52x20.6	1
4	34241100	Shaft	1
5	Q27500072	Woodruff 4x6.5	1
6	44113500	Shaft seal 18x30x7/7.5	1
7	39040000	Body	1

ORDERING CODE

SU/20-86- E

SU/20-86 = Belt pulley support

Series

E = Tapered shaft

1

REINFORCED SUPPORT, TAPERED SHAFT FOR FRONT FLANGE GR.2

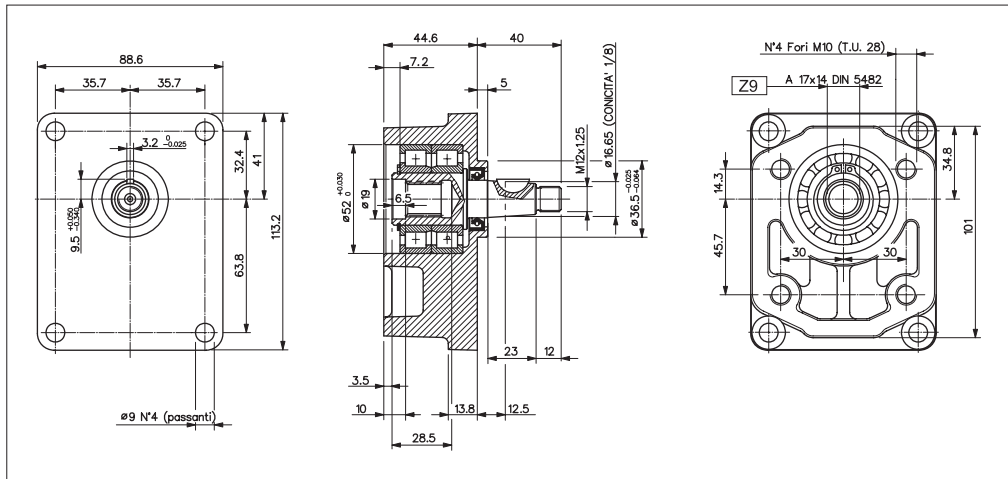

The SU/20-86-H is suitable for driving non-standard Gr. 2 pumps and motors with belts, chain or other transmission, in which heavy combined loads take place (axial and radial).

The pump/motor Gr. 2, is directly flanged and connected by splined coupling (coupling to be ordered separately).

MAXIMUM LOAD ON THE SHAFT

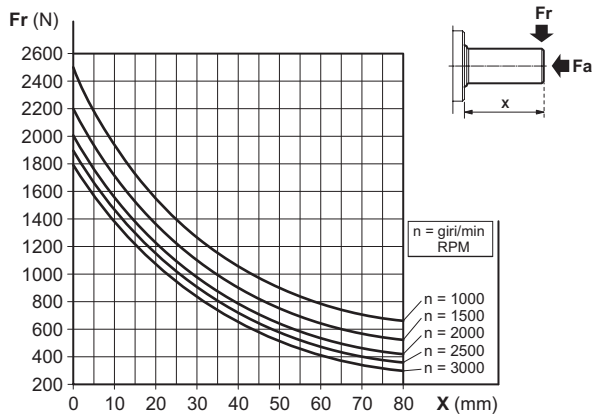

FEATURES

Minimum radial load	Fr = 155 N
Axial load	Fa ≤ Fr • 0,2
Max. revolutions per minute	4000 RPM
Life	3500 hours
Max. working temperature	70 °C
Grease quantity	13 ÷ 17 gr
Type of grease	DIN 51818 NLGI classe 2

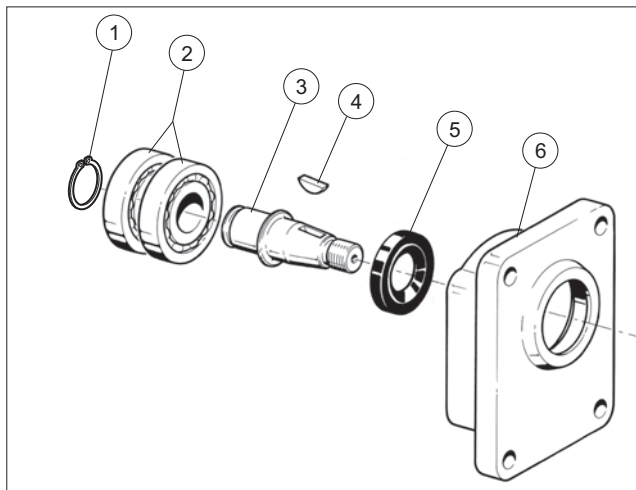

SPARE PARTS

Ref.	Code	Description	Q.ty
1	Q27150250	Seeger D.26	1
2	44004800	Bearing 25x52x15	2
3	34254100	Shaft	1
4	43203200	Woodruff 3.2x6.5	1
5	44113500	Shaft seal 18x30x7/7.5	1
6	39045500	Body	1

ORDERING CODE

SU/20-86- H

SU/20-86 = Belt pulley support

Series

H = Tapered shaft

MECHANICAL CLUTCH, CYLINDRICAL SHAFT FLANGE FOR PUMP GR.1-2

2

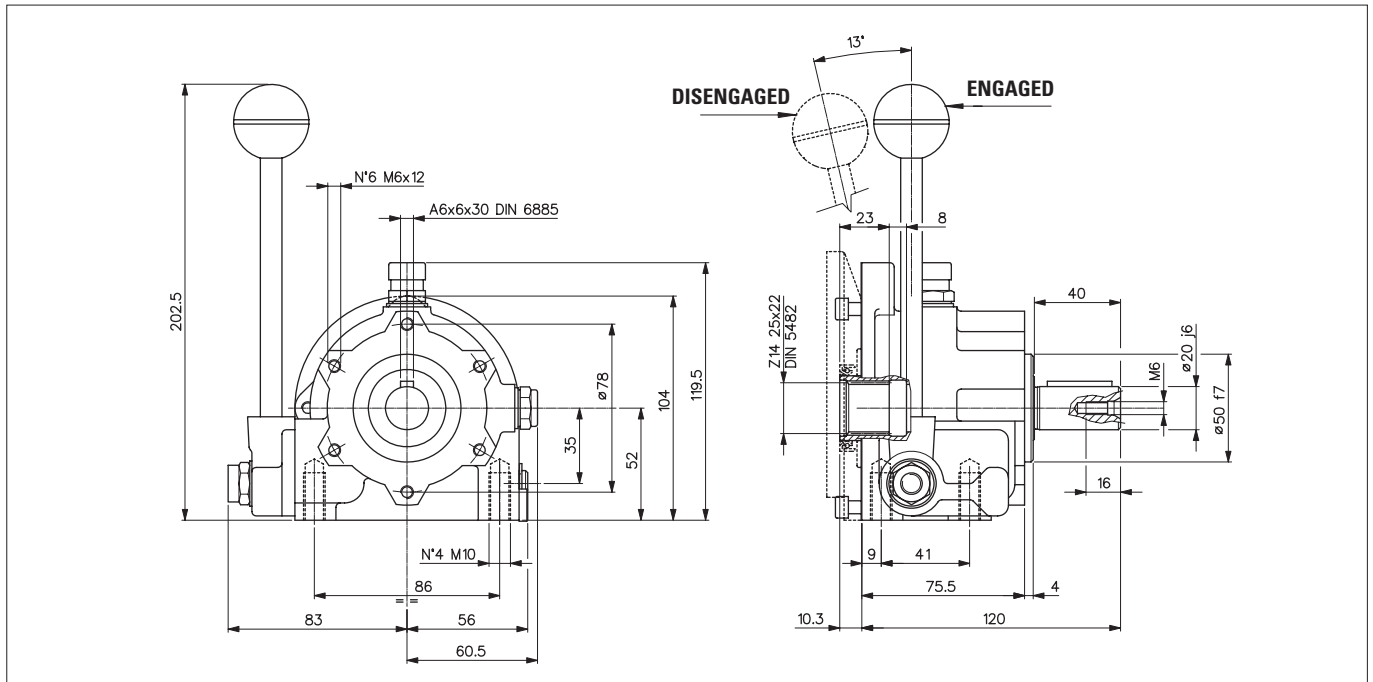

MAXIMUM LOAD ON THE SHAFT

The mechanical clutches IM05 are fitted between motor (electrical or engine) and hydraulic pump or motor, the pump or motor is engaged using a manual lever. Require flanges and coupling to connect pump and motor.

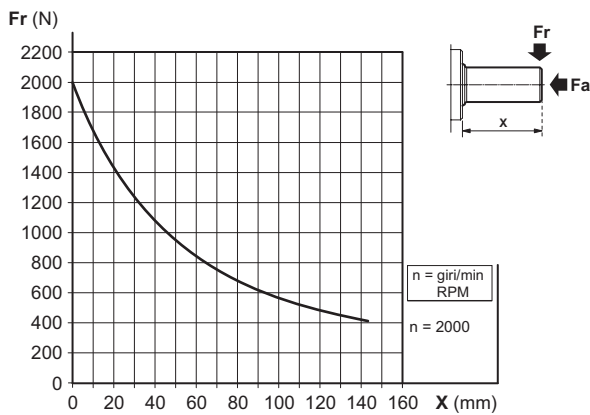

FEATURES

Max. axial load	Fa = 120 daN
RPM max	2000 RPM
Max engagement speed (*)	420 RPM
Max. torque	9 daNm
Life	3500 hours
Working temperature	-20 °C ÷ +80 °C
Oil quantity	0.2 lt.
Type of oil	CLP 150-ISO VG150
Oil replacement	12 months

(*) The engagement and disengagement must be done when the pump is unloaded max speed 420 RPM.

ORDERING CODE

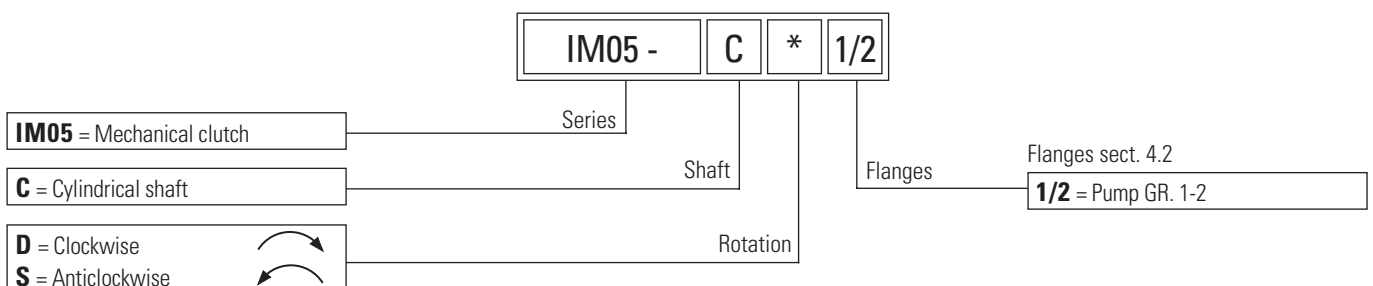

SPARE PARTS

2

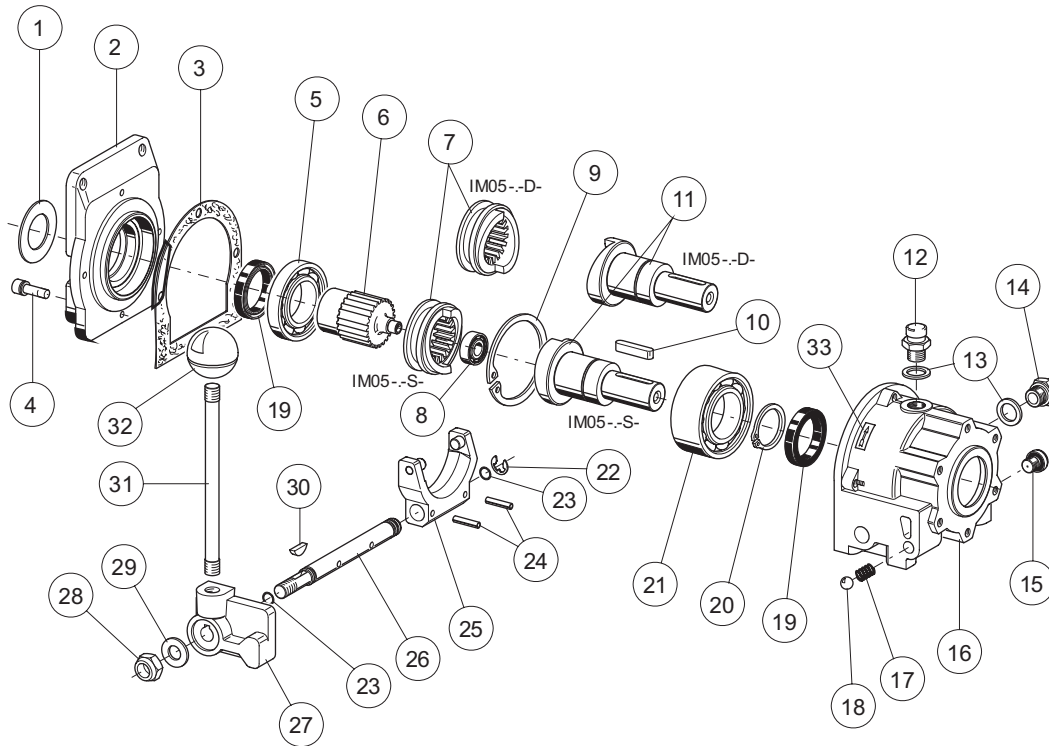

Ref.	Code	Q.ty		Description
		IM05-C-D-..	IM05-C-S-..	
1	39100800	1	1	Flange 44/1
2	39022800	1	1	Flange gr.1-2 (sect.4.2)
3	39203000	1	1	Gasket
4	40007300	4	4	Screw TCEI M6x20
5	44005600	1	1	Bearing 16006 30x55x9
6	34202800	1	1	Inlet shaft
7	31202800	1	—	Sleeve - right
	31202900	—	1	Sleeve - left
8	44005500	1	1	Bearing 608 8x22x7
9	Q27160062	1	1	Snap ring I62
10	Q27470211	1	1	Key A6x6x30
11	34202700	1	—	Outlet shaft - right
	34203100	—	1	Outlet shaft - left
12	49100100	1	1	Plug G.1/4
13	49000100	2	2	Nylon washer 13x19x1.5
14	49100200	1	1	Level plug G.1/4
15	49145100	1	1	Plug with O-Ring G.1/8
16	39003800	1	1	Standard body

Ref.	Code	Q.ty		Description
		IM05-C-D-..	IM05-C-S-..	
17	39100400	1	1	Spring
18	Q28620056	1	1	Ball D.8,5
19	44101800	2	2	Shaft seal 30x40x7
20	Q27150300	1	1	Snap ring E30
21	44005200	1	1	Bearing 3206 30x62x23,8
22	Q27100012	1	1	Ring
23	Q25830015	2	2	O-Ring 8.74x1.78
24	Q27420186	2	2	Needle 4x20
25	29000011	1	1	Yoke
26	34300700	1	1	Pin
27	39103200	1	1	Plate
28	Q26560330	1	1	Nut M10x10
29	Q26769015	1	1	Washer 10,5x21x2
30	Q27500072	1	1	Key 4x6.5
31	34300100	1	1	Lever
32	49100400	1	1	Knob D.35
33	LAB00014	1	1	Label

MECHANICAL CLUTCH, CYLINDRICAL SHAFT FLANGE FOR PUMP GR.2-3 / SAE A / SAE B

2

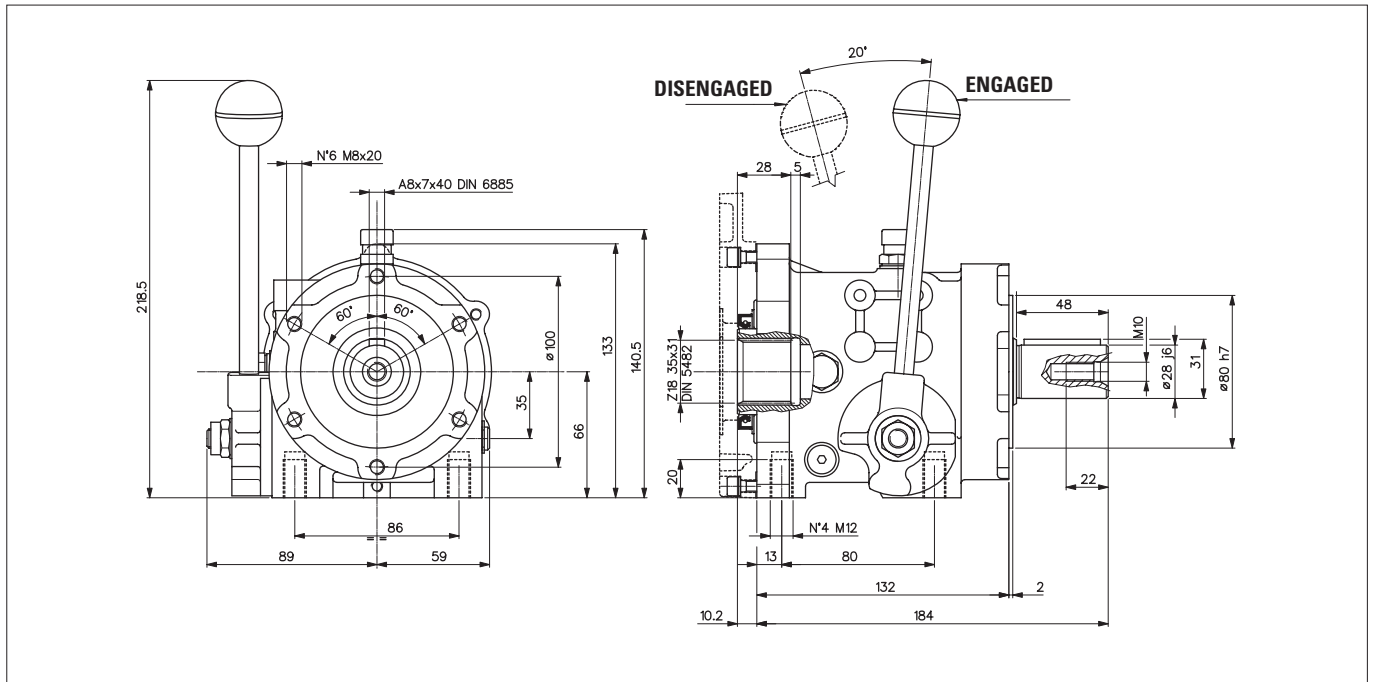

MAXIMUM LOAD ON THE SHAFT

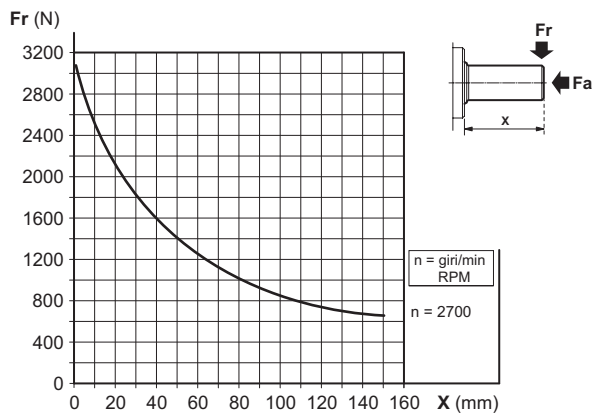

The mechanical clutches IM1 are fitted between motor (electrical or engine) and hydraulic pump or motor, the pump or motor is engaged using a manual lever.

FEATURES

Max. axial load	$F_a \leq F_r \cdot 0,2$
RPM max	2700 RPM
Max engagement speed (*)	420 RPM
Max. torque	19 daNm
Life	3500 hours
Working temperature	-20 °C ÷ +80 °C
Oil quantity	0.5 lt.
Type of oil	CLP 150-ISO VG150
Oil replacement	12 months

(*) The engagement and disengagement must be done when the pump is unloaded max speed 420 RPM. In the reversible type we suggest 300 RPM as maximum speed to operate the engagement.

ORDERING CODE

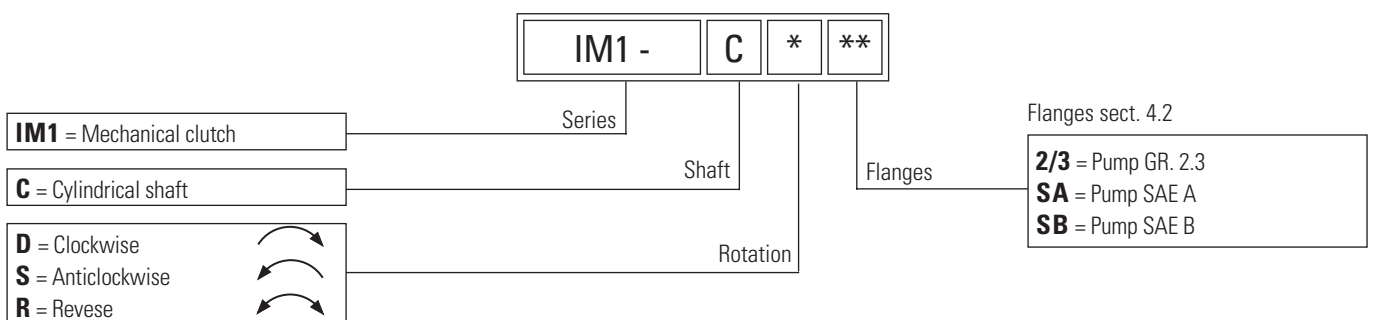

SPARE PARTS

2

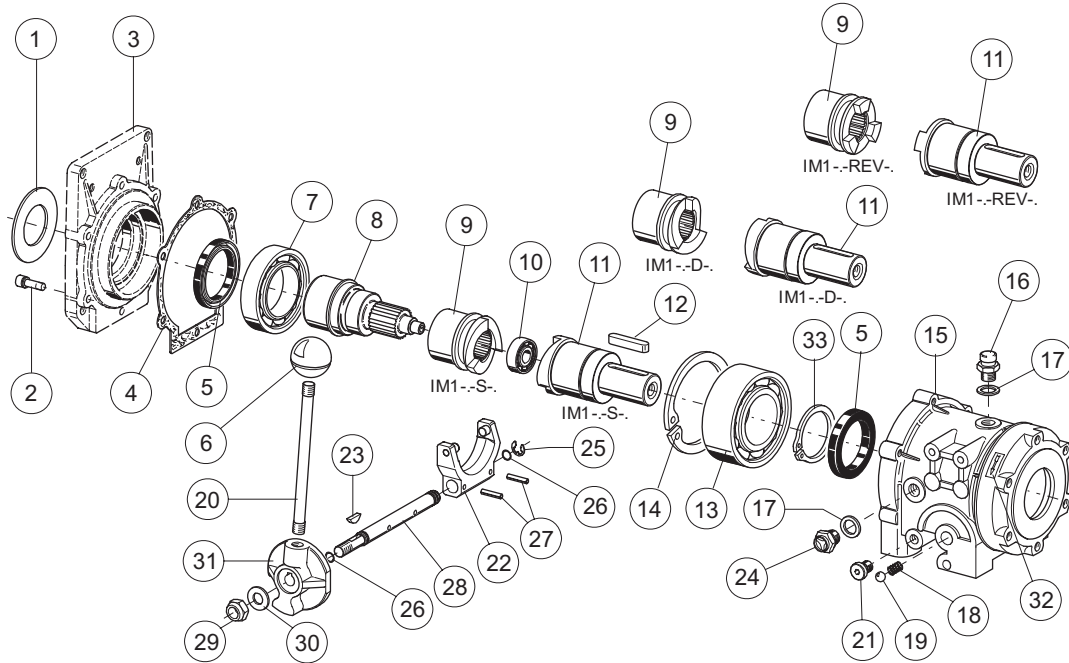

Ref.	Code	Q.ty			Description
		IM1-C-D..	IM1-C-S..	IM1-C-REV..	
1	39101200	1	1	1	Flange D.66/36,5 (only for gr.2-3)
2	40007300	6	6	6	Screw TCEI M6x20
3	—	1	1	1	Flanges (sect.4.2)
4	39204400	1	1	1	Gasket
5	44102200	2	2	2	Shaft seal 45x60x7
6	49100400	1	1	1	Knob D.35
7	44000300	1	1	1	Bearing 6009 45x75x16
8	34200100	1	1	1	Inlet shaft
9	31205000	1	—	—	Sleeve - right
	31204900	—	1	—	Sleeve - left
	31205900	—	—	1	Sleeve - reversible
10	44005700	1	1	1	Bearing 6200 10x30x9
11	34254600	1	—	—	Outlet shaft - right
	34254500	—	1	—	Outlet shaft - left
	34254700	—	—	1	Outlet shaft - reversible
12	Q27470305	1	1	1	Key A8x7x40
13	44005800	1	1	1	Bearing 3209 45x85x30,2
14	Q27160085	1	1	1	Snap ring I85
15	39045700	1	1	1	Body

Ref.	Code	Q.ty			Description
		IM1-C-D..	IM1-C-S..	IM1-C-REV..	
16	49100100	1	1	1	Plug G.1/4
17	49000100	2	2	2	Nylon washer 13x19x1.5
18	39100400	1	1	1	Spring
19	Q28620056	1	1	1	Ball D.8,5
20	34300100	1	1	1	Lever
21	49145100	1	1	1	Plug with O-Ring G.1/8
22	29000011	1	1	1	Yoke
23	Q27500072	1	1	1	Key 4x6.5
24	49100200	1	1	1	Level plug G.1/4
25	Q27100012	1	1	1	Ring D.9
26	Q25830015	2	2	2	O-Ring 8.74x1.78
27	Q27420186	2	2	2	Needle 4x20
28	34300200	1	1	1	Pin
29	Q26560330	1	1	1	Nut M10x10
30	Q26769015	1	1	1	Washer 10,5x21x2
31	39100200	1	1	1	Collet
32	LAB00014	1	1	—	Label
33	Q27150450	1	1	1	Snap ring E45

MECHANICAL CLUTCH, CYLINDRICAL SHAFT

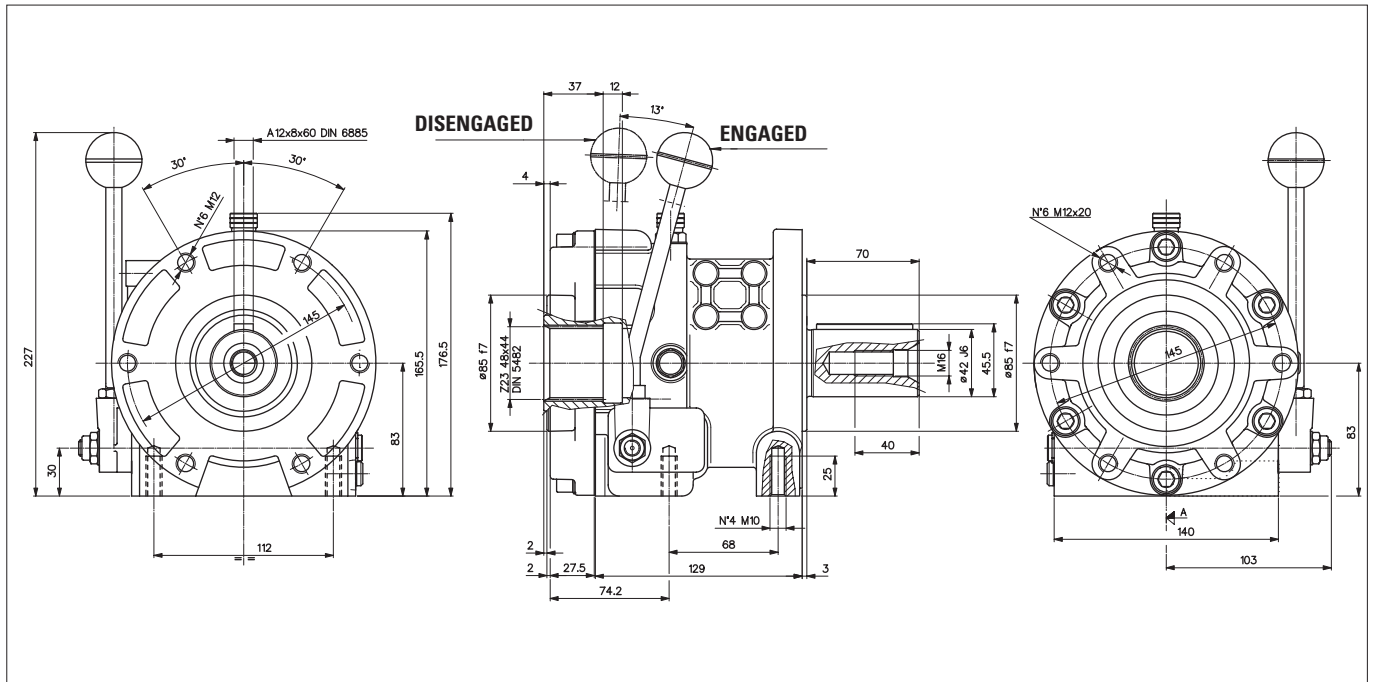

MAXIMUM LOAD ON THE SHAFT

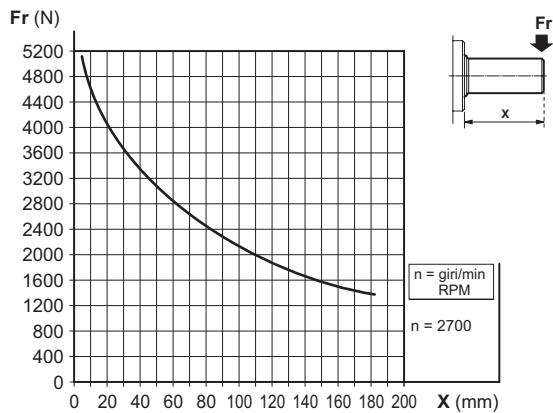

The mechanical clutches IM2 are fitted between motor (electrical or engine) and hydraulic pump or motor, the pump or motor is engaged using a manual lever.

FEATURES

RPM max	2700 RPM
Max engagement speed (*)	420 RPM
Max. torque	60 daNm
Life	3500 hours
Working temperature	-20 °C ÷ +80 °C
Oil quantity	0.4 lt.
Type of oil	CLP 150-ISO VG150
Oil replacement	12 months

(*) The engagement and disengagement must be done when the pump is unloaded max speed 420 RPM. In the reversible type we suggest 300 RPM as maximum speed to operate the engagement.

ORDERING CODE

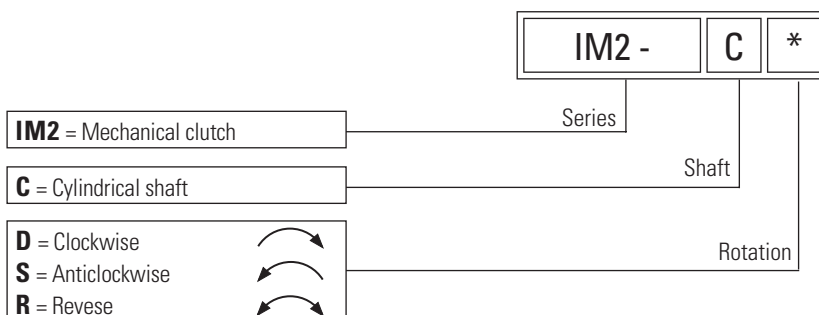

Flanges sect. 4.1

A	SAE A	F	GR. 3.5
B	SAE B	G	GR. 4
C	SAE C	L	ISO 1
D	GR. 2	M	ISO 2
E	GR. 3	P	ISO 3

SPARE PARTS

2

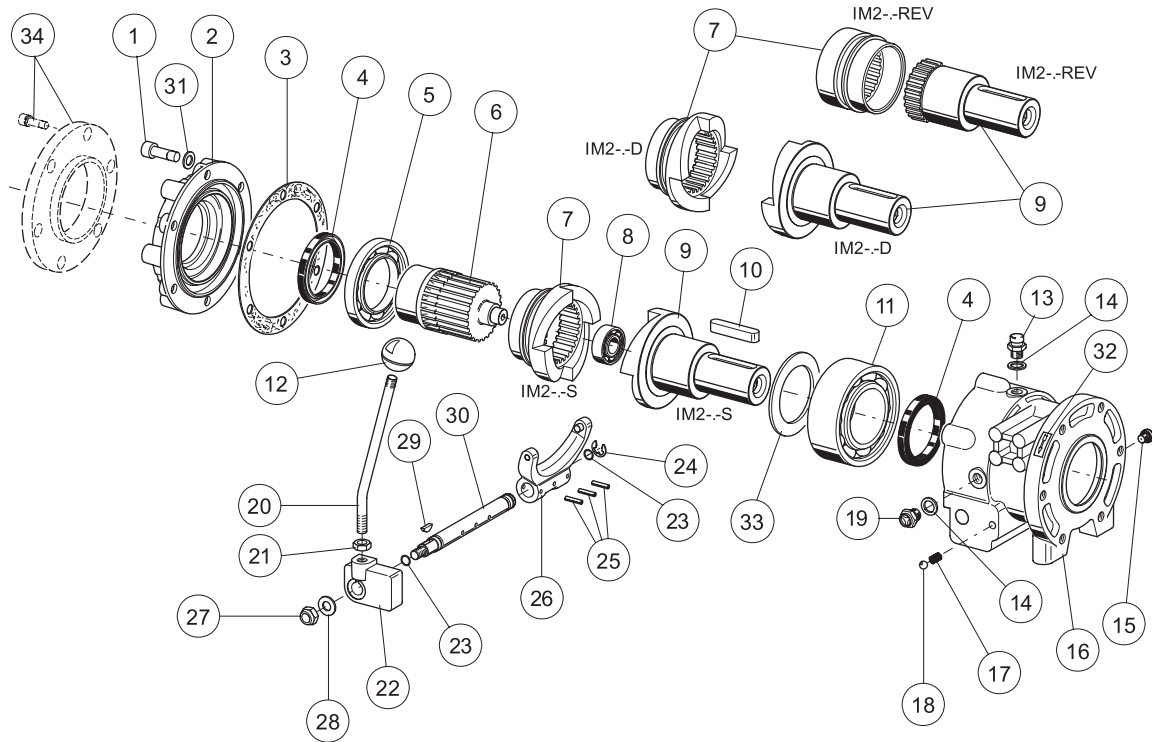

Ref.	Code	Q.ty			Description
		IM2-C-D	IM2-C-S	IM2-C-R	
1	Q26075125	6	6	6	Screw TCEI M10x30
2	39030400	1	1	1	Cover
3	39200200	1	1	1	Gasket
4	44103600	2	2	2	Shaft seal 60x75x8
5	44005900	1	1	1	Bearing 16012 60x95x11
6	34201400	1	1	1	Inlet shaft
7	31200300	1	—	—	Sleeve - right
	31200400	—	1	—	Sleeve - left
	31209400	—	—	1	Sleeve - reversible
8	44006000	1	1	1	Bearing 6203 17x40x12
9	34201200	1	—	—	Outlet shaft - right
	34201300	—	1	—	Outlet shaft - left
	34238900	—	—	1	Outlet shaft - reversible
10	Q27470413	1	1	1	Key A12x8x60
11	44006100	1	1	1	Bearing 3212 60x110x36,5
12	49100400	1	1	1	Knob D.35
13	49100100	1	1	1	Plug G.1/4
14	49000100	2	2	2	Nylon washer 13x19x1.5
15	49145100	1	1	1	Plug with O-Ring G.1/8

Ref.	Code	Q.ty			Description
		IM2-C-D	IM2-C-S	IM2-C-R	
16	39001300	1	1	1	Body
17	39100400	1	1	1	Spring
18	Q28620056	1	1	1	Ball D.8,5
19	49100200	1	1	1	Level plug G.1/4
20	34300400	1	1	1	Lever
21	Q26514069	1	1	1	Nut M10x6
22	39101900	1	1	1	Plate
23	Q25830083	2	2	2	O-Ring 10.77x2.62
24	Q27100014	1	1	1	Ring D.12
25	Q27420186	3	3	3	Needle 4x20
26	29000012	1	1	1	Yoke
27	Q26560330	1	1	1	Nut M10x10
28	Q26769015	1	1	1	Washer 10,5x21x2
29	Q27500072	1	1	1	Key 4x6.5
30	34300500	1	1	1	Pin
31	Q26801010	6	6	6	Washer Schnorr D.10
32	LAB00014	1	1	—	Label
33	39116400	—	—	1	Flange D.75x3x60
34	—	1	1	1	Flange kit (sect. 4.1)

MECHANICAL CLUTCH, DIN 5482 Z24 SHAFT

2

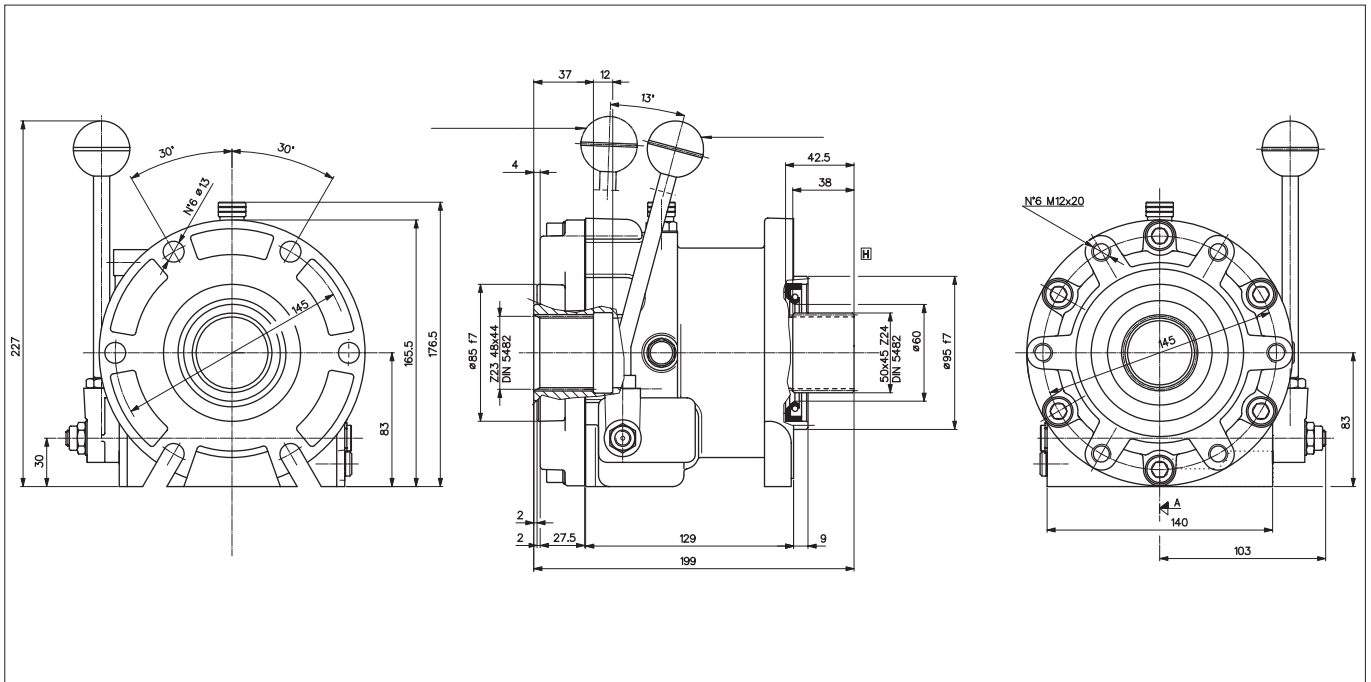

MAXIMUM LOAD ON THE SHAFT

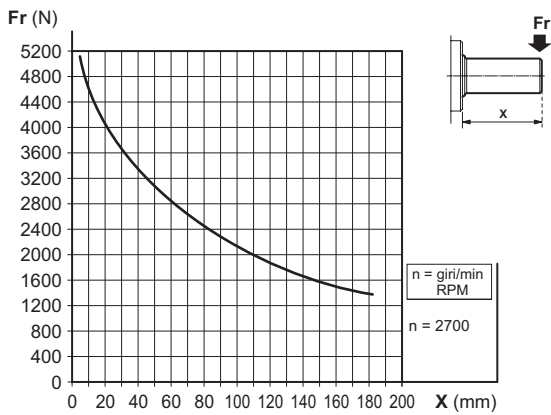

The mechanical clutches "IM2 Universale" are fitted between motor (electrical or engine) and hydraulic pump or motor, the pump or motor is engaged using a manual lever.

FEATURES

RPM max	2700 RPM
Max engagement speed (*)	420 RPM
Max. torque	60 daNm
Life	3500 hours
Working temperature	-20 °C ÷ +80 °C
Oil quantity	0.4 lt.
Type of oil	CLP 150-ISO VG150
Oil replacement	12 months

(*) The engagement and disengagement must be done when the pump is unloaded max speed 300 RPM (reversible type).

ORDERING CODE

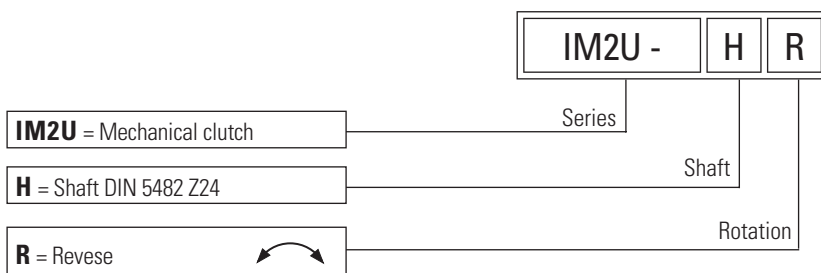

Flanges sect. 4.1

A	SAE A	F	GR. 3.5
B	SAE B	G	GR. 4
C	SAE C	L	ISO 1
D	GR. 2	M	ISO 2
E	GR. 3	P	ISO 3

SPARE PARTS

2

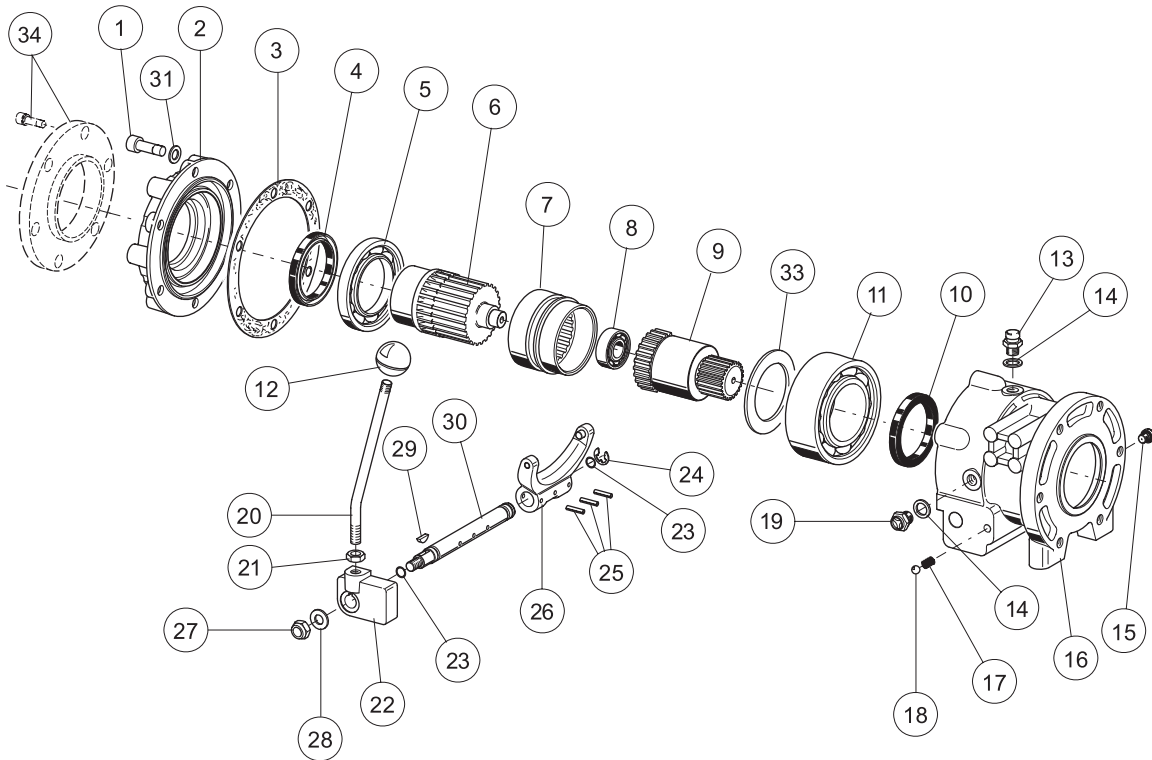

Ref.	Code	Q.ty	Description
		IM2U-H-R	
1	Q26075125	6	Screw TCEI M10x30
2	39030400	1	Cover
3	39200200	1	Gasket
4	44103600	1	Shaft seal 60x75x8
5	44005900	1	Bearing 16012 60x95x11
6	34201400	1	Inlet shaft
7	31209400	1	Sleeve - reversible
8	44006000	1	Bearing 6203 17x40x12
9	34239000	1	Outlet shaft Z.24 - reversible
10	44105000	1	Shaft seal 60x85x10
11	44006100	1	Bearing 3212 60x110x36,5
12	49100400	1	Knob D.35
13	49100100	1	Plug G.1/4
14	49000100	2	Nylon washer 13x19x1.5
15	49145100	1	Plug with O-Ring G.1/8
16	39002500	1	Body
17	39100400	1	Spring

Ref.	Code	Q.ty	Description
		IM2U-H-R	
18	Q28620056	1	Ball D.8,5
19	49100200	1	Level plug G.1/4
20	34300400	1	Lever
21	Q26514069	1	Nut M10x6
22	39101900	1	Plate
23	Q25830083	2	O-Ring 10.77x2.62
24	Q27100014	1	Ring D.12
25	Q27420186	3	Needle 4x20
26	29000012	1	Yoke
27	Q26560330	1	Nut M10x10
28	Q26769015	1	Washer 10,5x21x2
29	Q27500072	1	Key 4x6.5
30	34300500	1	Pin
31	Q26801010	6	Washer Schnorr S10
33	39116400	1	Flange D.75x3x60
34	—	1	Flange kit (sect. 4.1)

ELECTROMAGNETIC CLUTCH - OIL LUBRICATION

3

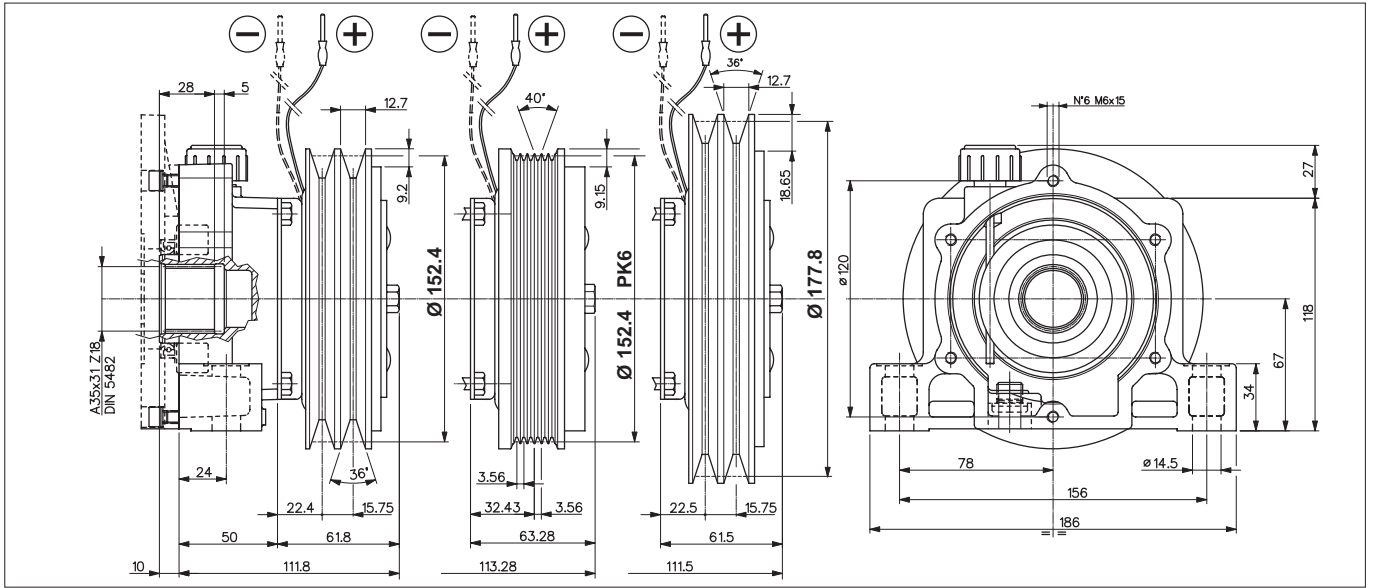

MAXIMUM LOAD ON THE SHAFT

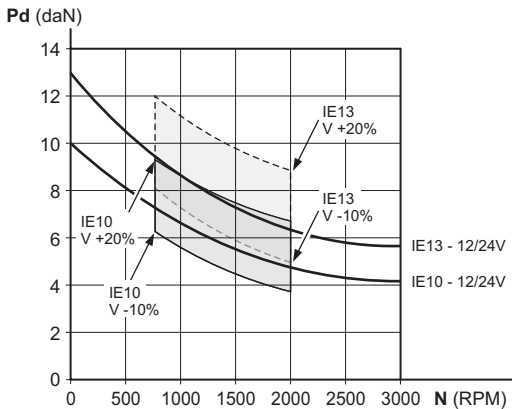

Approximate calculation of drive torque

$$P \text{ (daNm)} = c \cdot p \cdot 0,0017$$

$$P < Pd$$

where:

p = pump pressure in BAR
c = pump displacement in cc/revolution

from diagram:

Pd = Max. torque allowed by the coupling in daNm
n = Motor rotation speed in rpm.

* Input tension and operating temperature considerably influence the correct operation of the clutch. At temperatures above 70 °C the dynamic torque rating is reduced by 20%. To reach the maximum torque, run the clutch in through repeated working cycles (ON/OFF).

An electromagnetic clutch is a unit designed to convey movement to a UT hydraulic pump through an electrically controlled on/off pulley.

An electromagnetic clutch is composed of:

- an electromagnetic friction clutch (FE)
- an aluminium support (SU) with a conical (AT) and splined (UT) shaft mounted on oil-bath bearings.
- coupling to be ordered separately

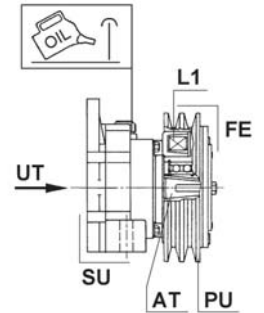

Description

This type of clutch exploits the force of attraction of an electromagnetic field generated by a solenoid that, after being energised (L1 in ON position), connects a pulley to a driving shaft.

The electromagnetic friction clutch is composed of two separate parts:

- a solenoid L1, mounted on the support;
- a pulley PU, mounted on the conical shaft AT.

Operations are as follows:

- under non operating conditions with L1 in OFF position: the pulley, driven by the "V" belt, turns idle on its own bearing,
- under operating conditions with L1 in ON position: the pulley, driven by the "V" belt, conveys movement to the shaft, then to the user UT.

FEATURES

RPM max	5000 RPM
Static nominal torque (*)	10.2 daNm (pulley Ø152.4 - 2 races) 10.2 daNm (pulley Ø152.4 - 6 races) 12.2 daNm (pulley Ø177.8 - 2 races)
Power supply	12 Vdc - 50W 24 Vdc - 60W
Preferred rotation (pulley side)	CW
Working temperature	-10 °C ÷ +45 °C
Max working temperature coil (*)	100 °C
Oil quantity	0,07 lt.
Type of oil	ISO 3498 category CKC 150 viscosity ISO 3488
Grease replacement	After first 500hours then every 12 months

ORDERING CODE

3

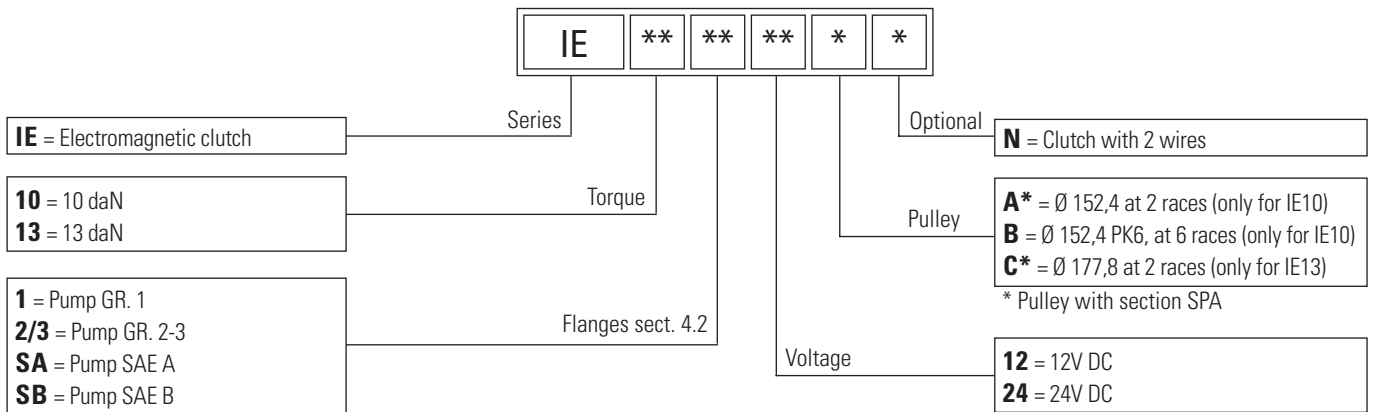

SPARE PARTS

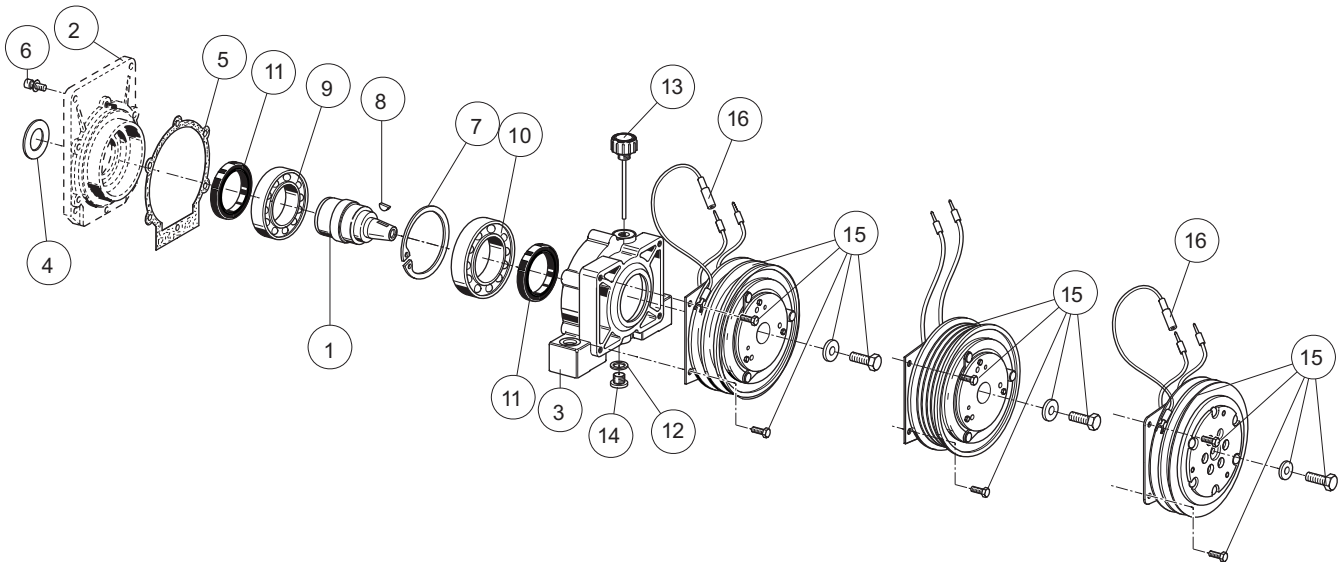

Ref.	Code	Q.ty			Description
		IE10..A..	IE10..B..	IE13..C..	
1	34241900	1	1	1	Shaft
2	—	1	1	1	Flanges (sect. 4.2)
3	39042700	1	1	1	Body
4	39101000	1	1	1	Flange D.66/25,4 (only for gr.1)
4	39101200	1	1	1	Flange D.66/36,5 (only for gr.2-3)
5	39204400	1	1	1	Gasket
6	40007300	6	6	6	Screw TCEI M6x20
7	Q27160080	1	1	1	Snap ring 180
8	Q27500070	1	1	1	Key 4x5 DIN 6888
9	44000300	1	1	1	Bearing 600945x75x16
10	44001200	1	1	1	Bearing 6010 50x80x16

Ref.	Code	Q.ty			Description
		IE10..A..	IE10..B..	IE13..C..	
11	44102200	2	2	2	Shaft seal 45x60x7
12	49000100	1	1	1	Washer nylon 13x19x1.5
13	49138600	1	1	1	Plug 1/4"
14	Q26622252	1	1	1	Plug TCEI G1/4
15	46004700	1	—	—	Clutch D.152.4 x 2 - 10 daNm - 12Vdc
	46004800	1	—	—	Clutch D.152.4 x 2 - 10 daNm - 24Vdc
	46008400	—	1	—	Clutch D.152.4 x 6 - 10 daNm - 12Vdc
	46008500	—	1	—	Clutch D.152.4 x 6 - 10 daNm - 24Vdc
	46005200	—	—	1	Clutch D.177.8 x 2 - 13 daNm - 12Vdc
	46008200	—	—	1	Clutch D.177.8 x 2 - 13 daNm - 24Vdc
16	26000005	1	—	1	Wire L=65

ELECTROMAGNETIC CLUTCH - GREASE LUBRICATION

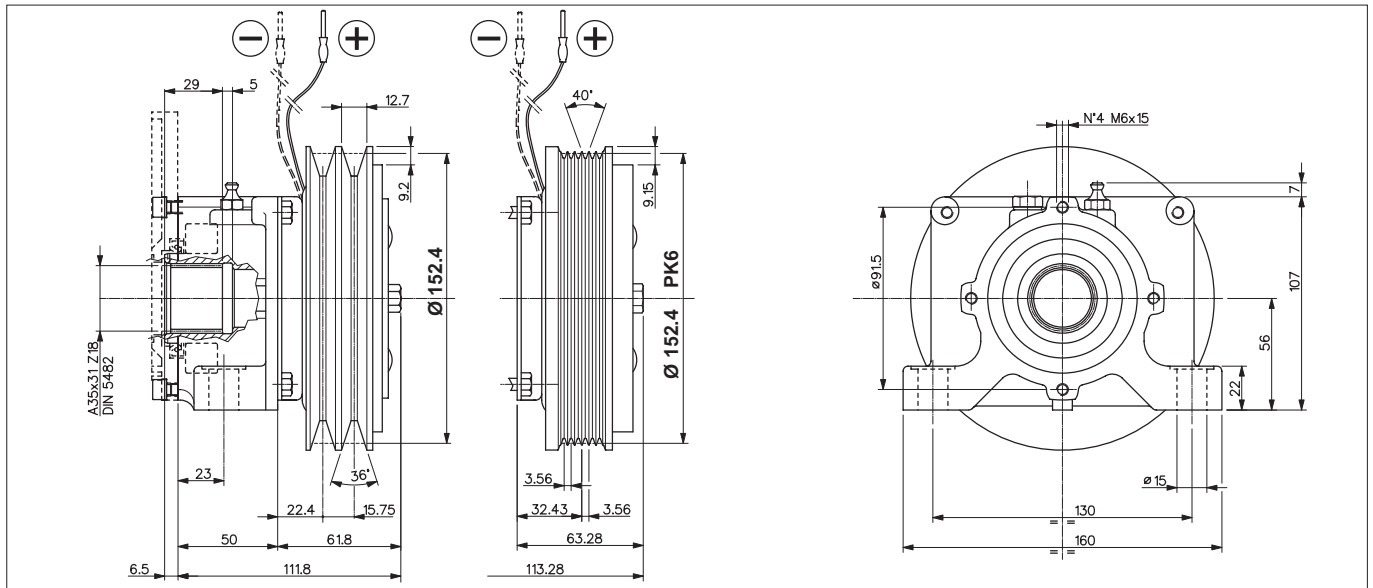

3

MAXIMUM LOAD ON THE SHAFT

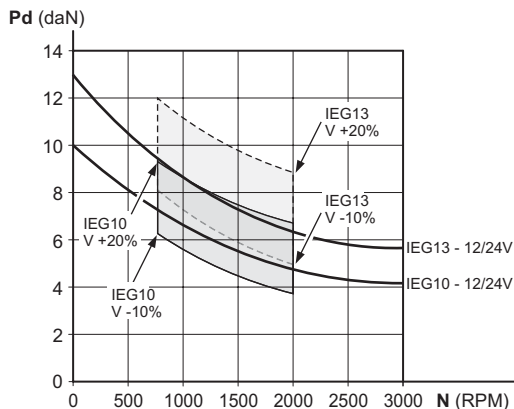

Approximate calculation of drive torque

$$P \text{ (daNm)} = c \cdot p \cdot 0,0017$$

$$P < Pd$$

where:

- p** = pump pressure in BAR
- c** = pump displacement in cc/revolution

from diagram:

- Pd** = Max. torque allowed by the coupling in daNm
- n** = Motor rotation speed in rpm.

* Input tension and operating temperature considerably influence the correct operation of the clutch. At temperatures above 70 °C the dynamic torque rating is reduced by 20%. To reach the maximum torque, run the clutch in through repeated working cycles (ON/OFF).

An electromagnetic clutch is a unit designed to convey movement to a UT hydraulic pump through an electrically controlled on/off pulley.

- An electromagnetic clutch is composed of:
- an electromagnetic friction clutch (FE)
 - an aluminium support (SU) with a conical (AT) and splined (UT) shaft mounted on grease bearings.
 - coupling to be ordered separately

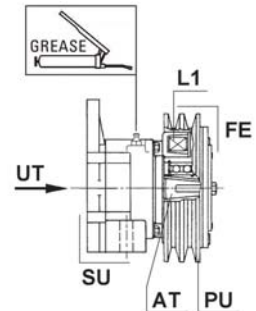

Description

This type of clutch exploits the force of attraction of an electromagnetic field generated by a solenoid that, after being energised (L1 in ON position), connects a pulley to a driving shaft.

The electromagnetic friction clutch is composed of two separate parts:

- a solenoid L1, mounted on the support;
- a pulley PU, mounted on the conical shaft AT.

Operations are as follows:

- under non operating conditions with L1 in OFF position: the pulley, driven by the "V" belt, turns idle on its own bearing,
- under operating conditions with L1 in ON position: the pulley, driven by the "V" belt, conveys movement to the shaft, then to the user UT.

FEATURES

RPM max	5000 RPM
Static nominal torque (*) (at 12/24V ± 0,5%)	10.2 daNm (pulley Ø152.4 - 2 races)
	10.2 daNm (pulley Ø152.4 - 6 races)
	12.2 daNm (pulley Ø177.8 - 2 races)
Power supply	12 Vdc - 50W
	24 Vdc - 60W
Preferred rotation (pulley side)	CW
Working temperature	-10 °C ÷ +45 °C
Max working temperature coil (*)	100 °C
Grease quantity	30 gr
Type of grease	DIN 51502 = MPF - 1K-20

ORDERING CODE

3

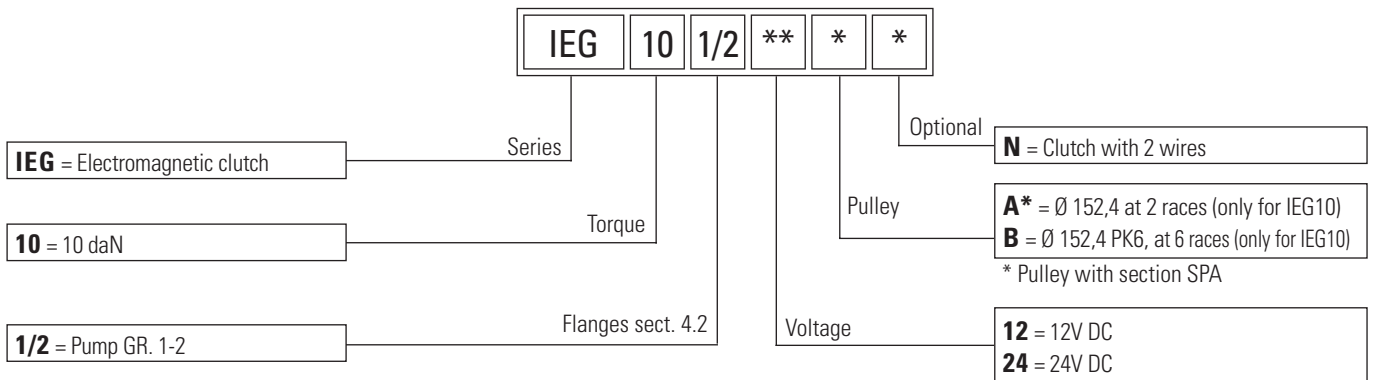

SPARE PARTS

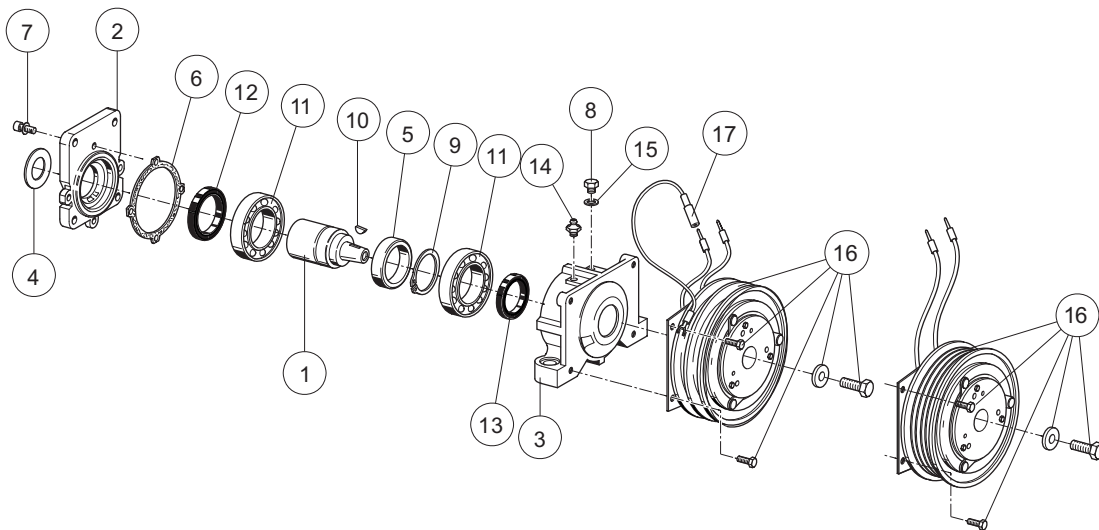

Ref.	Code	Q.ty		Description
		IEG10..A..	IEG10..B..	
1	34202300	1	1	Shaft
2	39017400	1	1	Flange Gr.1-2 (sect 4.2)
3	39021300	1	1	Body
4	39100800	1	1	Flange 44/1
5	39103000	1	1	Spacer
6	39204500	1	1	Gasket
7	40007300	4	4	Screw TCEI M6x20
8	Q26035090	1	1	Screw TEE M8x10
9	Q27150450	1	1	Snap ring E45
10	Q27500070	1	1	Key 4x5 DIN 6888
11	44000300	2	2	Bearing 6009 45x75x16

Ref.	Code	Q.ty		Description
		IEG10..A..	IEG10..B..	
12	44102200	1	1	Shaft seal 45x60x7
13	44102400	1	1	Shaft seal 35x50x7
14	49101000	1	1	Grease nipple
15	Q51437008	1	1	Washer aluminium M8 8.5x15x1.5
16	46004700	1	—	Clutch D.152.4 x 2 - 10 daNm - 12Vdc
	46004800	1	—	Clutch D.152.4 x 2 - 10 daNm - 24Vdc
	46008400	—	1	Clutch D.152.4 x 6 - 10 daNm - 12Vdc
	46008500	—	1	Clutch D.152.4 x 6 - 10 daNm - 24Vdc
17	26000005	1	—	Wire L=65

<p>A</p>	<p>B</p>	<p>C</p>																																
<p>Spare parts flange and screw kit</p>	<p>14050012</p>	<p>Spare parts flange and screw kit</p>	<p>14050011</p>	<p>Spare parts flange and screw kit</p>	<p>14050055</p>																													
<p>D</p>	<p>E</p>	<p>F</p>																																
<p>Spare parts flange and screw kit</p>	<p>1405008</p>	<p>Spare parts flange and screw kit</p>	<p>14050005</p>	<p>Spare parts flange and screw kit</p>	<p>14050006</p>																													
<p>G</p>	<p>L</p>	<p>M</p>																																
<p>Spare parts flange and screw kit</p>	<p>14050062</p>	<p>Spare parts flange and screw kit</p>	<p>14050010</p>	<p>Spare parts flange and screw kit</p>	<p>14050013</p>																													
<p>P</p>	<table border="1"> <thead> <tr> <th>Pump type</th> <th>Z</th> <th>H</th> </tr> </thead> <tbody> <tr> <td>A SAE A</td> <td>25</td> <td>25</td> </tr> <tr> <td>B SAE B</td> <td>12</td> <td>25</td> </tr> <tr> <td>C SAE C</td> <td>15</td> <td>28</td> </tr> <tr> <td>D GR. 2</td> <td>22</td> <td>22</td> </tr> <tr> <td>E GR. 3</td> <td>22</td> <td>22</td> </tr> <tr> <td>F GR. 3.5</td> <td>24.5</td> <td>24.5</td> </tr> <tr> <td>G GR. 4</td> <td>36</td> <td>36</td> </tr> <tr> <td>L ISO 1</td> <td>20.5</td> <td>26.5</td> </tr> <tr> <td>M ISO 2</td> <td>33</td> <td>43</td> </tr> <tr> <td>P ISO 3</td> <td>57</td> <td>72</td> </tr> </tbody> </table>	Pump type	Z	H	A SAE A	25	25	B SAE B	12	25	C SAE C	15	28	D GR. 2	22	22	E GR. 3	22	22	F GR. 3.5	24.5	24.5	G GR. 4	36	36	L ISO 1	20.5	26.5	M ISO 2	33	43	P ISO 3	57	72
Pump type	Z	H																																
A SAE A	25	25																																
B SAE B	12	25																																
C SAE C	15	28																																
D GR. 2	22	22																																
E GR. 3	22	22																																
F GR. 3.5	24.5	24.5																																
G GR. 4	36	36																																
L ISO 1	20.5	26.5																																
M ISO 2	33	43																																
P ISO 3	57	72																																
<p>Spare parts flange and screw kit</p>	<p>14050060</p>																																	

FLANGES IM1 / IE

4

<p style="text-align: right;">GR. 1* 1</p> <p style="text-align: center;">* Only for IE</p>	<p style="text-align: right;">GR. 2-3 2/3</p>
<p>Spare part flange code 39043000</p>	<p>Spare part flange code 39012500</p>
<p style="text-align: right;">SAE/A S/A</p>	<p style="text-align: right;">SAE/B S/B</p>
<p>Spare part flange code 39030600</p>	<p>Spare part flange code 39030800</p>

FLANGES IEG

<p style="text-align: right;">GR. 1-2 1/2</p>	<p style="text-align: right;">GR. 1-2 1/2</p>
<p>Spare part flange code 39017400</p>	<p>Spare part flange code 39022800</p>

FLANGES IM05

<p style="text-align: right;">GR. 1-2 1/2</p>	<p style="text-align: right;">GR. 1-2 1/2</p>
<p>Spare part flange code 39022800</p>	<p>Spare part flange code 39022800</p>



Factory - Sede produttiva

Brevini Fluid Power S.p.A.

Via Moscova, 6 - Villaggio Crostolo

Casella Postale 3057- 42124 Reggio Emilia - Italy

Tel. +39 0522 270711 - Fax +39 0522 270660

www.hydr-app.com

HA TEC SU-IM-IE E 1009

DOC00031 rev.00



Via Natta, 1

42124 Reggio Emilia - Italy

Tel. +39 0522 748700

Fax +39 0522 748750

www.brevinifluidpower.com

sales@brevinifluidpower.com