

SAE "B" 4 HOLES

**S4**

Conforms to SAE J744

D010-D09/0505

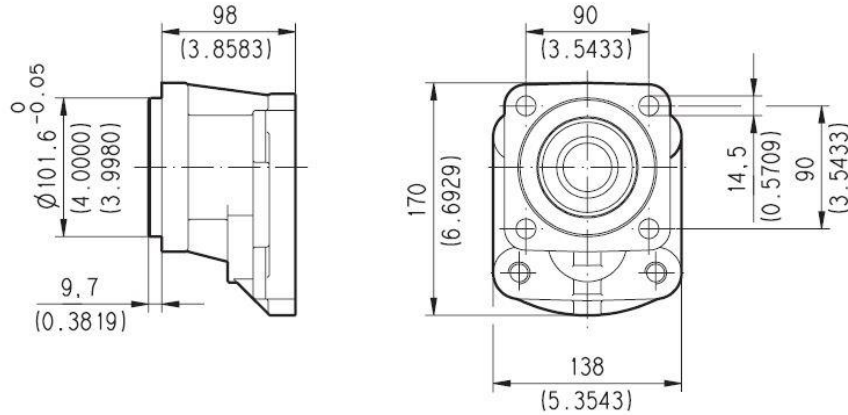

SAE "C" SPLINE

06

Mounting face refer to flange code S8

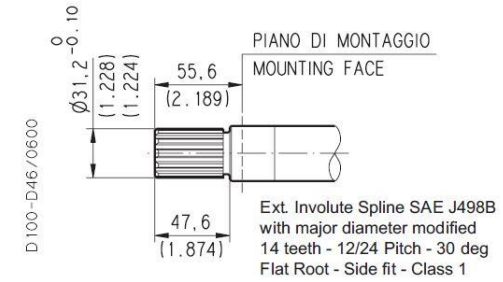

HD. 30 **MAX 170 Nm (1505 lbf in) ◆**

HD. 35 **MAX 900 Nm (7966 lbf in) ◆**

Pump type HDP Motor type HDM	Displacement in <sup>3</sup> /rev (cm <sup>3</sup> /rev)	Max. pressure			Max. speed	Min. speed
		p <sub>1</sub>	p <sub>2</sub>	p <sub>3</sub>		
		psi (bar)			min <sup>-1</sup>	
<b>HD. 35•40</b>	2.47 (40,46)	3915 (270)	4060 (280)	4495 (310)	3000	400
<b>HD. 35•50</b>	3.12 (51,10)	3915 (270)	4060 (280)	4495 (310)	3000	400
<b>HD. 35•63</b>	3.90 (63,88)	3915 (270)	4060 (280)	4495 (310)	3000	400
<b>HD. 35•71</b>	4.42 (72,40)	3625 (250)	4060 (280)	4350 (300)	3000	400
<b>HD. 35•80</b>	4.94 (80,91)	3625 (250)	4060 (280)	4350 (300)	3000	400
<b>HD. 35•90</b>	5.59 (91,56)	3335 (230)	3770 (260)	4060 (280)	2700	400
<b>HD. 35•100</b>	6.10 (100,08)	3045 (210)	3480 (240)	3770 (260)	2700	400
<b>HD. 35•112</b>	6.88 (112,85)	2755 (190)	3190 (220)	3480 (240)	2700	400
<b>HD. 35•125</b>	7.66 (125,63)	2465 (170)	2900 (200)	3190 (220)	2500	250

SAE FLANGED PORTS J518 - Standard pressure series 3000 PSI

SSM

Metric thread ISO 60° conforms to ISO/R 262

CODE	A	B	C	D		
	mm (in)	mm (in)	mm (in)	Thread Depth mm (in)	Nm (lbf in)	Nm (lbf in)
<b>MB</b>	19 (0.7480)	47,6 (1.8740)	22,2 (0.8740)	M 10 22 (0.8661)	20 <sup>+1</sup> (177 + 186)	35 <sup>+2,5</sup> (310 + 332)
<b>MC</b>	24,5 (0.9646)	52,4 (2.0630)	26,2 (1.0315)	M 10 22 (0.8661)	20 <sup>+1</sup> (177 + 186)	35 <sup>+2,5</sup> (310 + 332)
<b>MD</b>	30,5 (1.2008)	58,7 (2.3110)	30,2 (1.1890)	M 10 22 (0.8661)	20 <sup>+1</sup> (177 + 186)	35 <sup>+2,5</sup> (310 + 332)
<b>ME</b>	39,3 (1.5472)	69,8 (2.7480)	35,7 (1.4055)	M 12 27 (1.0630)	30 <sup>+2,5</sup> (266 + 288)	65 <sup>+5</sup> (575 + 620)
<b>MF</b>	51 (2.0079)	77,8 (3.0630)	42,9 (1.6890)	M 12 27 (1.0630)	30 <sup>+2,5</sup> (266 + 288)	—

D010-D15/0405

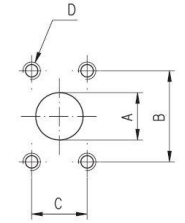

SAE FLANGED PORTS J518 - Standard pressure series 3000 PSI

SSS

American straight thread UNC-UNF 60° conforms to ANSI B 1.1

CODE	A	B	C	D		
	mm (in)	mm (in)	mm (in)	Thread Depth mm (in)	Nm (lbf in)	Nm (lbf in)
<b>SB</b>	19 (0.7480)	47,6 (1.8740)	22,2 (0.8740)	3/8 - 16 UNC-2B 22 (0.8661)	20 <sup>+1</sup> (177 + 186)	30 <sup>+2,5</sup> (266 + 288)
<b>SC</b>	24,5 (0.9646)	52,4 (2.0630)	26,2 (1.0315)	3/8 - 16 UNC-2B 22 (0.8661)	20 <sup>+1</sup> (177 + 186)	30 <sup>+2,5</sup> (266 + 288)
<b>SD</b>	30,5 (1.2008)	58,7 (2.3110)	30,2 (1.1890)	7/16 - 14 UNC-2B 28,5 (1.1220) 7/16 - 14 UNC-2B 27 (1.0630) (◆)	25 <sup>+1</sup> (221 + 230)	55 <sup>+5</sup> (487 + 531)
<b>SE</b>	39,3 (1.5472)	69,8 (2.7480)	35,7 (1.4055)	1/2 - 13 UNC-2B 27 (1.0630)	30 <sup>+2,5</sup> (266 + 288)	70 <sup>+5</sup> (620 + 664)
<b>SF</b>	51 (2.0079)	77,8 (3.0630)	42,9 (1.6890)	1/2 - 13 UNC-2B 27 (1.0630)	30 <sup>+2,5</sup> (266 + 288)	—

D010-D15/0405

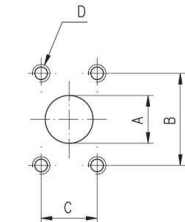

(◆) For MAGNUM 35